



EUROPEAN COMMISSION  
DIRECTORATE-GENERAL JRC  
JOINT RESEARCH CENTRE  
Institute for Prospective Technological Studies

## **Integrated Pollution Prevention and Control**

Reference Document on  
Best Available Techniques for the Production of

# **Speciality Inorganic Chemicals**

Dated October 2006

This document is one of a series of foreseen documents as below (at the time of writing, not all documents have been drafted):

<b>Reference Document on Best Available Techniques. . .</b>	<b>Code</b>
Large Combustion Plants	LCP
Mineral Oil and Gas Refineries	REF
Production of Iron and Steel	I&S
Ferrous Metals Processing Industry	FMP
Non Ferrous Metals Industries	NFM
Smitheries and Foundries Industry	SF
Surface Treatment of Metals and Plastics	STM
Cement and Lime Manufacturing Industries	CL
Glass Manufacturing Industry	GLS
Ceramic Manufacturing Industry	CER
Large Volume Organic Chemical Industry	LVOC
Manufacture of Organic Fine Chemicals	OFC
Production of Polymers	POL
Chlor – Alkali Manufacturing Industry	CAK
Large Volume Inorganic Chemicals - Ammonia, Acids and Fertilisers Industries	LVIC-AAF
Large Volume Inorganic Chemicals - Solid and Others industry	LVIC-S
<b><i>Production of Speciality Inorganic Chemicals</i></b>	<b><i>SIC</i></b>
Common Waste Water and Waste Gas Treatment/Management Systems in the Chemical Sector	CWW
Waste Treatments Industries	WT
Waste Incineration	WI
Management of Tailings and Waste-Rock in Mining Activities	MTWR
Pulp and Paper Industry	PP
Textiles Industry	TXT
Tanning of Hides and Skins	TAN
Slaughterhouses and Animals By-products Industries	SA
Food, Drink and Milk Industries	FDM
Intensive Rearing of Poultry and Pigs	ILF
Surface Treatment Using Organic Solvents	STS
Industrial Cooling Systems	CV
Emissions from Storage	ESB
<b>Reference Document . . .</b>	
General Principles of Monitoring	MON
Economics and Cross-Media Effects	ECM
Energy Efficiency Techniques	ENE

Electronic versions of draft and finalised documents are publically available and can be downloaded from <http://eippcb.jrc.es>.

## EXECUTIVE SUMMARY

The BAT (Best Available Techniques) Reference Document (BREF) entitled ‘Best Available Techniques for the Production of Speciality Inorganic Chemicals’ presents the result of the work carried out by a group of European experts in a Technical Working Group (TWG) to determine the Best Available Techniques for the production of these chemicals. This document reflects an information exchange carried out under Article 16(2) of Council Directive 96/61/EC (IPPC Directive).

This executive summary describes the main findings, a summary of the principal BAT conclusions and the associated consumption and emission levels. It should be read in conjunction with the preface, which explains the objectives of the document; how it is intended to be used and legal terms.

This executive summary can be read and understood as a standalone document but, as a summary, it does not present all the complexities of this full document. It is therefore not intended as a substitute for this full document as a tool in BAT decision making.

### Scope of this document

This document, together with other BREFs in the series, is intended to cover the activities described in Section 4 of the IPPC Directive, namely the ‘Chemical industry’. Within the chemical industry, this document focuses on the ‘Speciality Inorganic Chemicals’ (SIC) sector.

Because the IPPC Directive does not define the term SIC and since there is no common understanding of this term in industry, this document proposes criteria to differentiate between SIC and Large Volume Inorganic Chemicals (LVIC). In addition, the following working definition of SIC has been used for the purpose of this document:

*‘Speciality Inorganic Chemical (SIC) is taken to mean an inorganic substance manufactured industrially by chemical processing, generally in relatively small quantities, according to specifications (i.e. purity) tailored to meet the particular requirements of a user or industry sector (e.g. pharmaceutical).’*

Given the huge variety of SIC, associated raw materials and production processes, this document focuses on a limited number of (illustrative) families of SIC and concludes on BAT for each of these specific families. From the illustrative families and the specific associated BAT conclusions, this document infers generic (or common) BAT conclusions that are considered applicable to the production of a wider range of SIC. The illustrative families developed in this document are speciality inorganic pigments, phosphorus compounds, silicones, inorganic explosives and cyanides. The exchange of information on soluble inorganic salts of nickel could not be carried out to such an extent that BAT conclusions could be drawn, and it was consequently decided to remove the section on inorganic salts of nickel from this document.

### The SIC sector

Precise figures cannot be given for SIC industry sales because there is no common definition of SIC. It is thought however that, in Europe, the SIC sector represents between 10 and 20 % of the total chemical industry sales, and that sales are increasing slightly.

The SIC sector is characterised by its diversity and by its fragmentation. Thousands of SIC products are manufactured all over Europe using an immense range of raw materials and production processes. SIC installations are generally small to medium size installations using continuous or batch modes of operation. Some SIC installations produce only one type of SIC

while others are multipurpose plants capable of producing many different SIC. Companies of all sizes (from very large to very small) produce SIC at standalone installations or at installations that are part of a larger industrial complex.

Production in Europe is generally highly automated and computer-controlled although there are exceptions which include explosives and pigments production. The SIC sector is highly competitive and confidential in nature as companies tend to develop niche markets and focus on their competitive advantage. Competition is generally based on quality as opposed to price.

### **Key environmental issues**

Any substances might conceivably be a potential release to any medium because of the huge number of chemicals produced. In spite of this, the common environmental issues in the SIC sector as a whole include emissions of particulates to air (mainly dust and heavy metals); waste waters with high COD, heavy metals and/or salt loads; the consumption of energy and of water. The enormous variety of possibly produced and handled (also emitted) substances at SIC installations can also include highly harmful compounds having toxic or carcinogenic properties (e.g. cyanides, cadmium, lead, chromium (VI), arsenic). In addition, there are explosives among SIC substances. Health and safety can therefore be a crucial issue in the production of SIC substances. However, only some of these issues are relevant to individual SIC installations as shown by the illustrative families addressed in this document. The quality of end-products and the purity of raw materials are important factors influencing the environmental impact of the SIC sector.

### **Common applied techniques, consumption and emission levels**

Although processes for the production of SIC are extremely diverse and sometimes very complex (e.g. silicones), they are typically composed of a combination of simpler activities (or process steps) and equipment. These activities include dissolution of raw materials, mixing, synthesis/reaction or calcination, washing, drying, milling/grinding (wet or dry), sieving, condensation, distillation, evaporation, filtration, hydrolysis, extraction, compaction, granulation and briquetting. These process steps can be grouped under five general process stages which form the core activities in a SIC production process: raw and auxiliary materials supply, handling and preparation; synthesis/reaction/calcinations; product separation and purification; product storage and handling; and emissions abatement. This document briefly describes these activities and general process stages and highlights the associated environmental issues. This document also briefly describes the process equipment and infrastructure commonly used in the SIC sector, as well as the characteristics of its energy supply and management system.

Generic consumption and emission levels reflecting the whole SIC sector are difficult to provide because consumption and emission levels are specific to each SIC production process and only a few illustrative SIC processes have been examined in this document. This document therefore presents instead a checklist of possible emission sources and components against which assessments of any SIC production process can be made.

### **Common techniques to consider in the determination of BAT**

The generic techniques that have been considered in the determination of BAT for the whole SIC sector are generally presented in line with the generic approach in order to understand a SIC production process. Each technique is presented following the same outline to facilitate its evaluation and, when it is possible, to enable comparisons to be made between techniques.

Most of the common techniques are used in other chemical industry sectors and are described, generally in more detail, in other BREF documents (especially in the CWW BREF).

## Generic Best Available Techniques (BAT)

This document presents Best Available Techniques (BAT) at two levels: generic BAT valid for the whole SIC sector, and specific BAT valid for the illustrative families of SIC selected. BAT for the production of a speciality inorganic chemical pertaining to one of the illustrative SIC families is therefore the combination of the generic BAT elements and the specific BAT elements that can be found in this document. For the production of a SIC that does not pertain to one of these illustrative SIC families, only the generic elements apply.

In addition to the BAT referenced in this document, BAT for a SIC installation may also contain elements from other IPPC documents such as the BREFs on Emissions from Storage (ESB), Common Waste Water and Waste Gas Treatment/Management Systems in the Chemical Sector (CWW BREF).

With regard to the CWW BREF, it is worth noting the following points:

- the SIC BREF takes a more in-depth look into the application of some of the techniques identified in the CWW BREF for the production of speciality inorganic chemicals
- in order to reduce the need for the reader of this document to consult the CWW BREF, techniques used both in the SIC sector and in other chemical industry sectors are briefly described in this document. For more detailed information, the reader should refer to the CWW BREF.

The main conclusions reached for the generic BAT are summarised below.

### Raw and auxiliary materials supply, storage, handling and preparation

BAT is to reduce the amount of packaging materials disposed of by, e.g. recycling 'hard' and 'soft' used packaging materials, unless safety or hazard considerations prevent it.

### Synthesis/reaction/calcination

BAT is to reduce emissions and the amount of residues generated by implementing one or a combination of the following measures: using high purity feedstock; improving reactor efficiencies; improving catalyst systems.

For discontinuous processes, BAT is to optimise yields, lower emissions and reduce waste by sequencing the addition of reactants and reagents. BAT for discontinuous processes is also to minimise cleaning operations by optimising the sequences for addition of raw and auxiliary materials.

### Product handling and storage

BAT is to reduce the amount of residues generated, for example by using returnable product transportation containers/drums.

### Waste gas emissions abatement

This document presents BAT conclusions and associated emission levels for the abatement of HCN, NH<sub>3</sub>, HCl and Particulate Matters (PM). As an example, for PM BAT is to minimise emissions of total dust in off-gases and achieve emission levels in the range of 1 – 10 mg/Nm<sup>3</sup> by using techniques described in this document. The lower end of the range may be achieved by using fabric filters in combination with other abatement techniques. However, the range may be higher, depending on the carrier gas and particulate characteristics. Using fabric filters is not always possible, e.g. when pollutants other than dust have to be abated or when the off-gases present humid conditions. The PM recovered/removed are recycled back into production when this is feasible. The scrubbing medium is recycled when this is feasible.

### Waste water management and water emissions abatement

Waste water treatment in the SIC sector follows at least three different strategies:

- pretreatment within the premises of the SIC installation and final treatment(s) in a central WWTP within the premises of a larger site where the SIC installation is located
- pretreatment and/or final treatment(s) in a WWTP within the premises of the SIC installation
- pretreatment within the premises of the SIC installation and final treatment(s) in a municipal WWTP.

All three strategies are BAT when properly applied to the actual waste water situation.

No generic BAT conclusions on the abatement of heavy metals in waste water were derived. However, BAT conclusions on heavy metals abatement from waste water specific to three of the five illustrative families of SIC addressed in this document have been drawn, namely for speciality inorganic pigments, silicones and inorganic explosives. For information on heavy metals abatement in waste water in the production of substances not covered in the illustrative families sections of this document, it is recommended to refer to the CWW BREF.

As a general measure, BAT is to allocate contaminated waste water streams according to their pollutant load. Inorganic waste water without relevant organic components is segregated from organic waste water and ducted to special treatment facilities.

This document also presents BAT conclusions for the collection and treatment of rainwater.

### Infrastructure

BAT is to minimise diffuse dust emissions in particular from the storage and handling of materials/products by applying one or more of the following techniques: storing materials in closed systems, using covered areas protected from rain and wind, having production equipment totally or partially enclosed, having equipment designed with hooding and ducting to capture diffuse dust emissions and abating them, carrying out housekeeping regularly. BAT is to reduce fugitive gaseous and liquid emissions by applying one or more of the following measures: having periodic leak detection and repair programmes, operating equipment at slightly below atmospheric pressure, replacing flanges by welded connections, using seal-less pumps and bellow valves, using high performance sealing systems, carrying out housekeeping regularly.

For new installations, BAT is to use a computerised control system to operate the plant. However, this does not apply where safety issues do not permit automatic operations (e.g. in the production of SIC explosives).

For installations where solid hazardous compounds can build up in pipelines, machines and vessels, BAT is to have in place a closed cleaning and rinsing system.

### Energy

BAT is to reduce the consumption of energy by optimising plant design, construction and operation, for example by using pinch methodology, unless safety issues prevent it.

### Cross-boundary techniques

Where substances which represent a potential risk of contamination of ground and groundwater are handled, BAT is to minimise soil and groundwater pollution by designing, building, operating and maintaining facilities, in such a way that material escapes are minimised. This document provides the specific list of techniques that are considered BAT.

BAT is to have a high level of education and continuous training of personnel. This includes having personnel with sound basic education in chemical engineering and operations, continuously training plant personnel on the job, regularly evaluating and recording the performance of personnel, and regularly training personnel on how to respond to emergency situations, health and safety at work, and on product and transportation safety regulations.

BAT is to apply the principles of an Industry Code if available. This includes the following: applying very high standards for safety, environmental and quality aspects in the production of the SIC; carrying out activities such as auditing, certification, training of plant personnel.

BAT is to carry out a structured safety assessment for normal operation and to take into account effects due to deviations of the chemical process and deviations in the operation of the plant. In order to ensure that a process can be controlled adequately, BAT is to apply one or more of the following techniques: organisational measures, control engineering techniques, reaction stoppers, emergency cooling, pressure resistant construction, pressure relief systems.

A number of environmental management techniques are determined as BAT. The scope and nature of the Environmental Management System (EMS) will generally be related to the nature, scale and complexity of the installation, and the range of environmental impacts it may have. BAT is to implement and adhere to an EMS that incorporates, as appropriate to individual circumstances, features that include the definition of an environmental policy, planning, establishing and implementing procedures, checking performance and taking corrective action, having the management system and audit procedure examined and validated by an accredited certification body or an external EMS verifier.

## **Illustrative families of Speciality Inorganic Chemicals**

### Speciality inorganic pigments

#### *General information and applied processes and techniques*

The information contained in this document focuses on speciality inorganic pigments produced industrially by chemical processes (such as iron oxide pigments, complex inorganic coloured pigments, zinc sulphide, barium sulphate and lithopone pigments). Other (non-speciality) inorganic pigments, in particular titanium dioxide and carbon black pigments, are in the scope of the Large Volume Inorganic Chemicals – Solid and Others (LVIC-S) BREF. In Europe, speciality inorganic pigments are produced in small to large installations using a continuous or a batch mode of operation. Production is mainly located in Germany, Italy and Spain. Pigments production is considered a mature industrial sector where little new development is foreseen.

Although many production processes have been developed to manufacture the very large variety of inorganic pigments, production may be broken down in two main processes: pigment synthesis followed by pigment processing. The synthesis of pigments is carried out using a wet precipitation process or a dry calcination process each having a different environmental impact. The wet chemical process requires a large amount of water and generates a large amount of waste water, whereas the dry calcination process requires less water but more energy and gives rise to more off-gas emissions. Pigment processing includes washing, drying, calcination, mixing/milling, filtration/screening, and drying operations. Pigment processing gives rise to emissions to air and water. Of particular concern is the emission of particulates containing heavy metals to air.

#### *Consumption/emissions levels and techniques to consider in the determination of BAT*

This document provides consumption and emission levels from a sample of plants producing pigments in Europe. Techniques to consider in the determination of BAT include the use of non-carcinogenic raw materials, fluoride abatement by lime washing, the use of distilled water coming from the evaporation/concentration system for washing pigments, the removal of chromium from waste water, the recycling of precipitation sludge back into production, the biological treatment of waste water loaded with nitrates, the pretreatment and final treatment of waste water loaded with heavy metals.

### *Best Available Techniques*

In some instances, the diversity of the production processes and raw materials used led to BAT conclusions which are only applicable to certain pigments and/or when certain processes are carried out. Examples of BAT that have a wider applicability are presented below (i.e. concerning PM, acid gases and waste water).

BAT is to capture dust in the work areas and duct it to abatement. The abated dust is then recycled back into production. BAT is also to carry out regular housekeeping of the work areas.

BAT is to minimise the emission of acid gases and fluorides by using sorbent injection techniques for example.

BAT is to minimise the emission of total dust from the activities carried out at the installation and achieve emission levels of 1 – 10 mg/Nm<sup>3</sup> by using techniques such as cyclone, fabric filter, wet scrubber, ESP. The lower end of the range may be achieved by using fabric filters in combination with other abatement techniques. Using fabric filters is not always possible, for example when other pollutants have to be abated or when the off-gases present humid conditions.

For waste water, BAT is to (pre)treat waste water contaminated with Cr(VI) and achieve a Cr(VI) concentration of <0.1 mg/l by flow buffering and reducing Cr(VI) to Cr(III), for example using sulphite or iron (II) sulphate. BAT is also to pretreat the waste water loaded with heavy metals before discharging to the receiving water by a combination of techniques indicated in this document. The filtration residues recovered from the waste water treatment may be recycled back into production.

## Phosphorus compounds

### *General information and applied processes and techniques*

The phosphorus compounds addressed in this document are phosphorus trichloride (PCl<sub>3</sub>), phosphoryl chloride (POCl<sub>3</sub>) and phosphorus pentachloride (PCl<sub>5</sub>). All three substances are very toxic. They are produced in Europe by six companies at seven sites. The main markets for phosphorus compounds are in agriculture and in the production of flame-retardants. Production is carried out at multipurpose plants using a continuous mode of operation.

Production of PCl<sub>3</sub>, POCl<sub>3</sub> and PCl<sub>5</sub> are closely related as PCl<sub>3</sub> is the starting material for the production of the other two compounds. PCl<sub>3</sub> is manufactured in Europe either using the gas-liquid or the gas phase reaction process. Elemental phosphorus and chlorine are the raw materials used to produce PCl<sub>3</sub>.

### *Consumption/emission levels and techniques to consider in the determination of BAT*

The main environmental issues of concern in the production of phosphorus compounds are HCl and phosphorus oxide emissions to air, as well as chlorides and phosphorous emissions to water. Techniques to consider in the determination of BAT include the use of hot condensate water to melt elemental phosphorus and to keep it in liquid form, the use of different systems to blanket elemental phosphorus, the use of elemental phosphorus with low organic and inorganic impurities, the use of scrubbing systems to abate phosphorus compounds in the waste gases, and storage measures.

### *Best Available Techniques*

BAT for phosphorus compounds relate mainly to the minimisation of waste, energy savings, the prevention of accidents, the production yield as well as the minimisation of chloride, and phosphorus emissions to the environment. Examples of these are presented below.



BAT is to reduce the consumption of energy required to melt the solid white/yellow elemental phosphorus raw material by using hot condensate water coming from other parts of the process.

BAT is to minimise the risk of fire by blanketing the elemental phosphorus raw material with an inert medium up to the reaction step.

BAT is to reduce HCl emissions to air from the production of phosphorus compounds and achieve emission levels of 3 – 15 mg/Nm<sup>3</sup> by alkaline scrubbing. To minimise emissions in all production conditions, flowrates through the scrubber system and alkali concentration in the scrubbing medium have to be sufficiently high.

BAT is to minimise emissions of phosphorus and chlorine to the receiving water by treating water effluents in a WWTP equipped with biological treatment and achieve emission levels of phosphorus to the receiving water of 0.5 – 2 kg/t of raw elemental phosphorus and emission levels of chlorine to the receiving water of 5 – 10 kg/t of raw elemental phosphorus.

Regarding waste, BAT is to achieve emission levels of waste distillation residues from  $\text{PCl}_3$  production of 4 – 8 kg/t of raw elemental phosphorus and to incinerate distillation residues.

## Silicones

### *General information and applied processes and techniques*

Silicones are a special variety of polymers. They differ from polymers as the backbone of their structure does not contain carbon, but is a chain of alternating silicon and oxygen atoms. Several thousands of different silicone products are on the market and a production site often manufactures over a thousand different silicone products. This document addresses the most important ones, namely polydimethylsiloxane (PDMS). Applications of silicones include electric isolators, lubricants, elastomers, coatings, additives in lacquers, paintings and cosmetic products. Four companies produce silicones in Europe, all using a continuous mode of operation.

PDMS is produced through the following process steps: methyl chloride synthesis, grinding of elemental silicon, direct synthesis (Müller-Rochow synthesis), distillation, and hydrolysis/condensation. The main raw materials are elemental silicon, HCl and methanol.

### *Consumption/emission levels and techniques to consider in the determination of BAT*

The main environmental issues are dust, chlorides and  $\text{NO}_x$  emissions to the air, as well as emission of copper and zinc to the receiving water. Techniques to consider in the determination of BAT include measures for the storage of elemental silicon, pinch methodology to optimise energy consumption, a dry dedusting system for the storage, handling and grinding of elemental silicon, different ways of recovering methyl chloride, thermal treatment of off-gases containing light hydrocarbons and chlorinated compounds, treatment of waste water, re-use/recovery of water and HCl, prevention of accidents.

### *Best Available Techniques*

BAT for the production of silicones mainly relate to the maximisation of the efficiency of the chemical reaction, the minimisation of materials used, the prevention of accidents, the minimisation of waste, the efficient use of energy, the reduction of emissions to air and water. Some examples are presented below.

BAT is to minimise diffuse dust emissions from the storage and handling of elemental silicon by applying measures indicated in this document. BAT is to reduce channelled dust emissions from elemental silicon grinding, storage and handling, and achieve emission levels of 5 – 20 mg/Nm<sup>3</sup> (yearly average) by using fabric filters, for example, and recycling the separated dust back into production.

To achieve maximum efficiency of the chemical reaction in the direct synthesis, BAT is to use elemental silicon raw materials with a particle size of <1 mm.

Regarding the prevention of accidents, BAT is to minimise the sources of ignition energy from elemental silicon grinding and to minimise the sources of explosions from grinding and conveying elemental silicon by maintaining the oxygen and/or elemental silicon dust content in the equipment atmosphere at a safe level below the LEL.

BAT is to reduce the consumption of energy by recycling the energy produced in the direct synthesis.

For waste water treatment, BAT is to minimise emissions of copper and zinc to water by pretreating the water effluents from PDMS production by precipitation/flocculation under alkaline conditions followed by sedimentation and filtration. BAT is also to reduce the BOD/COD content of the water effluent coming out of the pretreatment by applying a biological treatment step.

### SIC explosives

#### *General information and applied processes and techniques*

The inorganic explosives covered in this document are lead azide, lead trinitroresorcinate and lead picrate which are of industrial and economic importance in Europe. These substances are classified as 'primary explosives' whose main function is to initiate a 'secondary explosive' (e.g. in dynamites). Other uses include applications in air-bag inflators and seat-belt pretensioners. Inorganic explosives are produced batch wise.

The raw materials used are lead nitrate and sodium azide in the production of lead azide, lead nitrate and trinitroresorcine in the production of lead trinitroresorcinate and lead nitrate and sodium picrate in the production of lead picrate. SIC explosives are produced by a precipitation reaction. The resulting product is then purified and dried.

#### *Consumption/emission levels and techniques to consider in the determination of BAT*

The main environmental issues associated with inorganic explosives production are emissions to water of lead, nitrates, sulphates, COD and suspended solids. Techniques to consider in the determination of BAT include the removal of lead from waste waters by precipitation with sulphuric acid or sodium carbonate, the removal of traces of explosive materials containing lead from waste waters using a neutralisation station, and ground protection measures.

#### *Best Available Techniques*

This document presents BAT in areas that include accident prevention, waste minimisation and reduction of lead emissions to water. Some examples of BAT are presented below.

In order to avoid the 'domino effect' in the case of an explosion, BAT is to separate production and storage buildings on the production site. BAT is also to reduce the risk of explosions of electric origin by storing SIC explosives in buildings equipped with electrical protection and safety systems.

BAT for waste water includes the collection and treatment of used process waters, the removal of traces of explosive impurities in the waste water, the reduction of organic impurities in the waste water by using activated carbon. BAT is also to recycle waste water back into the production process where the production scale and/or the ratio between energy-cost/water-cost justifies this. Finally, BAT is to send the waste water to a central WWTP for treatment. If the central WWTP does not have denitrification treatment (and nitrification if necessary), BAT is to subsequently treat the waste water in a biological WWTP (on-site or off-site, e.g. municipal WWTP) with denitrification (and nitrification if necessary).

## Cyanides

### *General information and applied processes and techniques*

This document focuses on water soluble sodium cyanide (NaCN) and potassium cyanide (KCN). The other inorganic cyanide salts are not addressed due to their low production volume. Cyanides are mainly used in Europe in the chemical synthesis industry as well as in electroplating and metal hardening. NaCN and KCN are produced at less than a dozen sites in Europe in medium sized facilities using a continuous mode of operation.

This document addresses the production of NaCN and KCN by the water solution process which includes two main steps for the production of a solution of cyanides (i.e. neutralisation followed by filtration) and subsequent steps for the production of cyanides in solid forms (i.e. drying, compaction, granulation, separation from fine dust, sieving or briquetting). The raw materials are HCN and NaOH or KOH.

### *Consumption/emission levels and techniques to consider in the determination of BAT*

Emissions from the production of cyanides mainly consists of HCN and NH<sub>3</sub> to the air and of cyanides to the receiving waters. Techniques to consider in the determination of BAT include the destruction of cyanides from waste gases and waste waters using hydrogen peroxide, the thermal treatment of off-gases containing VOCs, the cleaning-in-place system for equipment contaminated with cyanide, the use of returnable packaging for the transport of solid cyanides, the use of a computerised control system to operate the plant, the application of the International Cyanide Management Code, storage measures for cyanides, the use of raw materials with low contents of heavy metals, the high level of education and continuous training of personnel.

### *Best Available Techniques*

This document presents BAT on waste reduction, minimisation of raw materials as well as on the abatement of NO<sub>x</sub>, HCN, NH<sub>3</sub> and VOCs. This document also presents BAT associated emission levels for these pollutants.

Regarding emissions of cyanides to water, this document concludes that BAT is to minimise these emissions by using techniques that oxidise cyanides. Using hypochlorite is also considered BAT when the cyanide-effluent stream is free of organic material and when no free hypochlorite is left in the effluent after the oxidation reaction. The associated BAT emission levels are also indicated in this document.

Several BAT for the prevention of soil pollution are also presented. Other BAT conclusions relate to water and energy consumption, product storage and packaging, plant operation and training of personnel.

## **Emerging techniques**

Some emerging techniques have been identified in the course of the work. These are: the decontamination of exhaust gases and waste water by chemically modified inorganic ion exchangers and active carbon, the utilisation of industrial waste as fuel, air filtration for the abatement of volatile chromium compounds, the development and application of advanced ceramic electrodes for the electrochemical elimination of cyanides in waste water.

**Concluding remarks**

The information exchange on BAT for the production of SIC was conducted in a period of about two years, from October 2003 to November 2005. The exchange of information was challenging because confidentiality concerns hampered the collection of actual consumption and emission data from individual SIC installations. However, this did not prevent the drawing of generic BAT conclusions valid for the whole SIC sector as well as BAT conclusions for the specific families of SIC addressed in this document. Consensus has been achieved on BAT and no split views were recorded.

The EC is launching and supporting, through its RTD programmes, a series of projects dealing with clean technologies, emerging effluent treatment and recycling technologies and management strategies. Potentially these projects could provide a useful contribution to future BREF reviews. Readers are therefore invited to inform the European IPPC Bureau of any research results which are relevant to the scope of this document (see also the preface of this document).

## PREFACE

### 1. Status of this document

Unless otherwise stated, references to “the Directive” in this document means the Council Directive 96/61/EC on integrated pollution prevention and control. As the Directive applies without prejudice to Community provisions on health and safety at the workplace, so does this document.

This document forms part of a series presenting the results of an exchange of information between EU Member States and industries concerned on best available technique (BAT), associated monitoring, and developments in them. \*[It is published by the European Commission pursuant to Article 16(2) of the Directive, and must therefore be taken into account in accordance with Annex IV of the Directive when determining “best available techniques”].

\* Note: bracket will be removed once the procedure of publication by the Commission is completed.

### 2. Relevant legal obligations of the IPPC Directive and the definition of BAT

In order to help the reader understand the legal context in which this document has been drafted, some of the most relevant provisions of the IPPC Directive, including the definition of the term “best available techniques”, are described in this preface. This description is inevitably incomplete and is given for information only. It has no legal value and does not in any way alter or prejudice the actual provisions of the Directive.

The purpose of the Directive is to achieve integrated prevention and control of pollution arising from the activities listed in its Annex I, leading to a high level of protection of the environment as a whole. The legal basis of the Directive relates to environmental protection. Its implementation should also take account of other Community objectives such as the competitiveness of the Community’s industry thereby contributing to sustainable development.

More specifically, it provides for a permitting system for certain categories of industrial installations requiring both operators and regulators to take an integrated, overall look at the polluting and consuming potential of the installation. The overall aim of such an integrated approach must be to improve the management and control of industrial processes so as to ensure a high level of protection for the environment as a whole. Central to this approach is the general principle given in Article 3 that operators should take all appropriate preventative measures against pollution, in particular through the application of Best Available Techniques enabling them to improve their environmental performance.

The term “best available techniques” is defined in Article 2(11) of the Directive as “the most effective and advanced stage in the development of activities and their methods of operation which indicate the practical suitability of particular techniques for providing in principle the basis for emission limit values designed to prevent and, where that is not practicable, generally to reduce emissions and the impact on the environment as a whole.” Article 2(11) goes on to clarify further this definition as follows:

“techniques” includes both the technology used and the way in which the installation is designed, built, maintained, operated and decommissioned;

“available” techniques are those developed on a scale which allows implementation in the relevant industrial sector, under economically and technically viable conditions, taking into consideration the costs and advantages, whether or not the techniques are used or produced inside the Member State in question, as long as they are reasonably accessible to the operator;

“best” means most effective in achieving a high general level of protection of the environment as a whole.

Furthermore, Annex IV of the Directive contains a list of “considerations to be taken into account generally or in specific cases when determining best available techniques ... bearing in mind the likely costs and benefits of a measure and the principles of precaution and prevention”. These considerations include the information published by the Commission pursuant to Article 16(2).

Competent authorities responsible for issuing permits are required to take account of the general principles set out in Article 3 when determining the conditions of the permit. These conditions must include emission limit values, supplemented or replaced where appropriate by equivalent parameters or technical measures. According to Article 9(4) of the Directive, these emission limit values, equivalent parameters and technical measures must, without prejudice to compliance with environmental quality standards, be based on the best available techniques, without prescribing the use of any technique or specific technology, but taking into account the technical characteristics of the installation concerned, its geographical location and the local environmental conditions. In all circumstances, the conditions of the permit must include provisions on the minimisation of long-distance or transboundary pollution and must ensure a high level of protection for the environment as a whole.

Member States have the obligation, according to Article 11 of the Directive, to ensure that competent authorities follow or are informed of developments in Best Available Techniques.

### **3. Objective of this Document**

Article 16(2) of the Directive requires the Commission to organise “an exchange of information between Member States and the industries concerned on best available techniques, associated monitoring and developments in them”, and to publish the results of the exchange.

The purpose of the information exchange is given in recital 25 of the Directive, which states that “the development and exchange of information at Community level about best available techniques will help to redress the technological imbalances in the Community, will promote the worldwide dissemination of limit values and techniques used in the Community and will help the Member States in the efficient implementation of this Directive.”

The Commission (Environment DG) established an information exchange forum (IEF) to assist the work under Article 16(2) and a number of technical working groups have been established under the umbrella of the IEF. Both IEF and the technical working groups include representation from Member States and industry as required in Article 16(2).

The aim of this series of documents is to reflect accurately the exchange of information which has taken place as required by Article 16(2) and to provide reference information for the permitting authority to take into account when determining permit conditions. By providing relevant information concerning best available techniques, these documents should act as valuable tools to drive environmental performance.

### **4. Information Sources**

This document represents a summary of information collected from a number of sources, including in particular the expertise of the groups established to assist the Commission in its work, and verified by the Commission services. All contributions are gratefully acknowledged.

### **5. How to understand and use this document**

The information provided in this document is intended to be used as an input to the determination of BAT in specific cases. When determining BAT and setting BAT-based permit conditions, account should always be taken of the overall goal to achieve a high level of protection for the environment as a whole.

The rest of this section describes the type of information that is provided in each section of the document.

Chapter 1 provides general information on the Speciality Inorganic Chemicals (SIC) industrial sector.

Chapter 2 describes the processes and techniques commonly used within the sector.

Chapter 3 provides information concerning common current consumption and emission levels reflecting the situation in existing SIC installations at the time of writing.

Chapter 4 describes, in a generic manner, the common emission reduction and other common techniques that are considered to be most relevant for determining BAT and BAT-based permit conditions. For each technique, this information includes the consumption and emission levels considered achievable by using the technique, some idea of the costs and the cross-media issues associated with the technique, and the extent to which the technique is applicable to the range of installations requiring IPPC permits, for example new, existing, large or small installations. Techniques that are generally seen as obsolete are not included.

Chapter 5 presents the techniques and, when possible, associated consumption and emission levels that are considered to be generic BAT for the SIC sector as a whole.

Chapter 6 considers, in detail, illustrative SIC families that have been chosen to elucidate the application of BAT in the SIC sector.

Chapter 5 and the BAT sections of Chapter 6 present the techniques and the consumption and emission levels that are considered to be compatible with BAT in a general sense. The purpose is thus to provide general indications regarding the consumption and emission levels that can be considered as an appropriate reference point to assist in the determination of BAT-based permit conditions or for the establishment of general binding rules under Article 9(8). It should be stressed, however, that this document does not propose emission limit values. The determination of appropriate permit conditions will involve taking account of local, site-specific factors such as the technical characteristics of the installation concerned, its geographical location and the local environmental conditions. In the case of existing installations, the economic and technical viability of upgrading them also needs to be taken into account. Even the single objective of ensuring a high level of protection for the environment as a whole will often involve making trade-off judgements between different types of environmental impact, and these judgements will often be influenced by local considerations.

Although an attempt is made to address some of these issues, it is not possible for them to be considered fully in this document. The techniques and levels presented in Chapter 5 and in the BAT sections of Chapter 6 will, therefore, not necessarily be appropriate for all installations. On the other hand, the obligation to ensure a high level of environmental protection including the minimisation of long-distance or transboundary pollution implies that permit conditions cannot be set on the basis of purely local considerations. It is, therefore, of the utmost importance that the information contained in this document is fully taken into account by permitting authorities.

Since the Best Available Techniques change over time, this document will be reviewed and updated as appropriate. All comments and suggestions should be made to the European IPPC Bureau at the Institute for Prospective Technological Studies at the following address:

Edificio Expo, c/Inca Garcilaso, s/n, E-41092 Sevilla, Spain  
Telephone: +34 95 4488 284  
Fax: +34 95 4488 426  
e-mail: [JRC-IPTS-EIPPCB@cec.eu.int](mailto:JRC-IPTS-EIPPCB@cec.eu.int)  
Internet: <http://eippcb.jrc.es>





---

# Best Available Techniques Reference Document for the Production of Speciality Inorganic Chemicals

<b>EXECUTIVE SUMMARY</b> .....	<b>I</b>
<b>PREFACE</b> .....	<b>XI</b>
<b>SCOPE</b> .....	<b>XXV</b>
<b>1 GENERAL INFORMATION</b> .....	<b>1</b>
1.1 The chemical industry in Europe .....	1
1.2 The SIC sector in Europe .....	1
1.2.1 Production and market features .....	2
1.2.2 Companies' profiles .....	2
1.2.3 Sector's outlook .....	3
1.2.4 Competition .....	3
1.3 Key environmental issues in the SIC sector .....	4
<b>2 COMMON APPLIED PROCESSES AND TECHNIQUES</b> .....	<b>5</b>
2.1 General features of a SIC production process .....	5
2.2 Common process steps .....	6
2.2.1 Dissolution of raw materials .....	7
2.2.2 Mixing .....	8
2.2.3 Synthesis/reaction .....	9
2.2.4 Calcination .....	9
2.2.5 Washing .....	10
2.2.6 Drying .....	10
2.2.7 Size reduction and separation operations .....	11
2.2.7.1 Dry milling/grinding .....	11
2.2.7.2 Wet milling .....	12
2.2.7.3 Sieving .....	12
2.2.8 Condensation .....	13
2.2.9 Distillation .....	13
2.2.10 Evaporation .....	15
2.2.11 Solid-liquid and solid-gas separations .....	16
2.2.12 Hydrolysis .....	17
2.2.13 Extraction .....	17
2.3 Raw and auxiliary materials and finished products storage and handling .....	18
2.4 Process-integrated measures for emissions prevention and reduction .....	18
2.5 Emissions abatement systems .....	19
2.5.1 General overview .....	19
2.5.2 Waste gas treatment techniques .....	20
2.5.3 Waste water treatment techniques .....	22
2.6 Process equipment and infrastructure .....	23
2.6.1 Reactors .....	23
2.6.2 Pumps, compressors and fans .....	25
2.6.3 Pipes .....	25
2.6.4 Valves .....	26
2.6.5 Utility fluids .....	26
2.6.6 Cooling and refrigeration systems .....	27
2.6.7 Cleaning systems .....	28
2.6.8 Vacuum systems .....	29
2.6.9 Storage systems .....	29
2.6.10 Transfer and handling systems .....	30
2.6.11 Monitoring practices .....	30
2.7 Energy supply .....	31
2.8 Management systems .....	31
<b>3 COMMON CONSUMPTION AND EMISSION LEVELS</b> .....	<b>33</b>
3.1 Air emissions .....	33
3.1.1 Diffuse emissions to air .....	36
3.1.2 Point source emissions to air .....	36
3.2 Water emissions .....	36
3.3 Wastes .....	38

3.4	Odour and noise emissions .....	41
3.5	Energy consumption .....	41
3.6	Water consumption .....	41
3.7	Factors influencing consumption and emission levels.....	41
3.7.1	Installation boundary definition and degree of integration.....	41
3.7.2	Determination of consumption and emission levels .....	42
3.7.3	Definition of waste .....	42
<b>4</b>	<b>COMMON TECHNIQUES TO CONSIDER IN THE DETERMINATION OF BAT .....</b>	<b>43</b>
4.1	Structure of this chapter.....	44
4.2	Raw and auxiliary materials and finished products supply, storage, handling and preparation.....	44
4.2.1	Recycling or re-use of used containers/drums .....	44
4.2.2	Recycling of used 'soft' packaging materials .....	45
4.2.3	Storage of liquid and liquefied gas .....	46
4.2.4	Transfer and handling of liquid and liquefied gas .....	46
4.2.5	Storage of solids .....	46
4.2.6	Handling of solids.....	46
4.3	Synthesis/reaction/calcination .....	47
4.3.1	Substitution of raw materials.....	47
4.3.2	Improving reactor efficiencies.....	48
4.3.3	Improving catalyst systems .....	49
4.3.4	Optimising processes.....	50
4.4	Emissions abatement .....	51
4.4.1	Waste water treatment techniques .....	51
4.4.1.1	Separation or clarification techniques.....	53
4.4.1.1.1	Sedimentation (including coagulation/flocculation) of solids.....	53
4.4.1.1.2	Air flotation .....	55
4.4.1.1.3	Filtration .....	56
4.4.1.1.4	Membrane filtration (microfiltration or ultrafiltration).....	57
4.4.1.2	Physical and/or chemical techniques .....	58
4.4.1.2.1	Precipitation.....	58
4.4.1.2.2	Crystallisation.....	60
4.4.1.2.3	Chemical oxidation .....	61
4.4.1.2.4	Chemical reduction.....	62
4.4.1.2.5	Nanofiltration (NF)/Reverse Osmosis (RO) .....	63
4.4.1.2.6	Adsorption .....	64
4.4.1.2.7	Ion exchange .....	66
4.4.1.2.8	Evaporation.....	67
4.4.1.2.9	Stripping .....	68
4.4.1.2.10	Incineration.....	69
4.4.2	Waste gas treatment techniques.....	70
4.4.2.1	Waste gas treatment techniques to abate particulate matter.....	70
4.4.2.1.1	Separators .....	70
4.4.2.1.2	Cyclones .....	72
4.4.2.1.3	Wet dust scrubber .....	73
4.4.2.1.4	Electrostatic precipitator (ESP).....	75
4.4.2.1.5	Fabric and ceramic filters.....	76
4.4.2.1.6	Two-stage dust filter .....	78
4.4.2.1.7	Absolute High Efficiency Particulate Arrestation (HEPA) filter.....	79
4.4.2.1.8	High Efficiency Air Filter (HEAF).....	81
4.4.2.1.9	Mist filter .....	82
4.4.2.2	Waste gas treatment techniques to abate VOCs and inorganic compounds.....	84
4.4.2.2.1	Membrane separation.....	84
4.4.2.2.2	Condensation and cryogenic condensation.....	86
4.4.2.2.3	Adsorption .....	87
4.4.2.2.4	Wet gas scrubber.....	89
4.4.2.2.5	Removal of HCN and NH <sub>3</sub> from waste gases .....	91
4.4.2.2.6	Twin-bed oxidiser systems .....	93
4.4.2.2.7	Incineration of exhaust gases containing Volatile Organic Compounds (VOCs).....	94
4.4.2.2.8	Catalytic oxidation.....	96
4.4.2.3	Waste gas treatment techniques to abate gaseous pollutants in combustion exhaust gases .....	97

4.4.2.3.1	Sorbent injection for abating acid gases and fluorides .....	97
4.4.2.3.2	Selective reduction of NO <sub>x</sub> (SNCR and SCR) .....	99
4.4.2.3.3	Wet SO <sub>2</sub> abatement techniques .....	100
4.4.3	Combined waste water and waste gas treatment techniques .....	101
4.4.3.1	Scrubbing and recycling of cyanides from waste gases and waste waters using hydrogen peroxide (H <sub>2</sub> O <sub>2</sub> ) as the oxidising agent .....	101
4.4.4	Treatment techniques of liquid (non-aqueous) and solid residues .....	103
4.4.4.1	Thickening and dewatering .....	103
4.4.4.2	Stabilisation and conditioning .....	105
4.4.4.3	Thermal sludge reduction .....	106
4.5	Infrastructure .....	106
4.5.1	Cleaning-In-Place (CIP) systems of equipment contaminated with solid hazardous compounds .....	106
4.5.2	Use of a computerised control system to operate the plant .....	108
4.6	Energy .....	109
4.6.1	Pinch methodology .....	109
4.7	Cross-boundary techniques .....	110
4.7.1	Ground protection .....	110
4.7.2	High level of education and continuous training of personnel .....	112
4.7.3	Application of an Industry Code (IC) .....	113
4.7.4	Rainwater collection and treatment .....	114
4.7.5	Safety assessment .....	115
4.7.5.1	Physico-chemical safety assessment of chemical reactions .....	115
4.7.5.2	Prevention of runaway reactions .....	119
4.7.6	Environmental management tools .....	120
<b>5</b>	<b>GENERIC BEST AVAILABLE TECHNIQUES .....</b>	<b>129</b>
<b>6</b>	<b>ILLUSTRATIVE FAMILIES OF SPECIALITY INORGANIC CHEMICALS .....</b>	<b>137</b>
6.1	Speciality inorganic pigments .....	137
6.1.1	General information .....	137
6.1.1.1	Uses .....	138
6.1.1.1.1	Iron oxide pigments .....	138
6.1.1.1.2	Complex Inorganic Coloured (CIC) pigments .....	139
6.1.1.1.3	Zinc sulphide pigments and precipitated barium sulphate (blanc fixe) .....	141
6.1.1.2	Toxicity .....	141
6.1.1.3	Speciality inorganic pigments production and consumption in Europe and worldwide .....	142
6.1.1.4	Features of the European speciality inorganic pigments industry .....	143
6.1.1.5	Economics .....	143
6.1.2	Applied processes and techniques .....	143
6.1.2.1	Pigment synthesis .....	144
6.1.2.1.1	Wet chemical process .....	145
6.1.2.1.2	Dry calcination process .....	145
6.1.2.1.3	Environmental impact of pigment synthesis .....	145
6.1.2.2	Pigment processing .....	146
6.1.2.3	Measures for reduction of emissions .....	146
6.1.2.3.1	Principle of waste gas treatment .....	146
6.1.2.3.2	Principle of waste water treatment .....	149
6.1.2.4	Iron oxide pigments .....	151
6.1.2.4.1	Precipitation and Penniman-Zoph processes .....	151
6.1.2.4.2	Laux process .....	155
6.1.2.5	Chromium (III) oxide pigments .....	157
6.1.2.5.1	Waste gas treatment .....	157
6.1.2.5.2	Waste water treatment .....	159
6.1.2.5.3	Waste .....	159
6.1.2.6	Complex Inorganic Coloured (CIC) pigments .....	159
6.1.2.6.1	Waste gas treatment .....	159
6.1.2.6.2	Waste water treatment .....	160
6.1.2.7	Zinc sulphide, barium sulphate and lithopone pigments .....	161
6.1.2.7.1	Zinc sulphide and lithopone pigments .....	161
6.1.2.7.2	Precipitated barium sulphate pigments .....	162
6.1.2.7.3	Waste water treatment .....	164
6.1.3	Consumption and emission levels .....	164

6.1.3.1	Raw materials, auxiliary chemicals, energy and water consumption.....	164
6.1.3.1.1	Energy consumption .....	164
6.1.3.1.2	Air emissions .....	165
6.1.3.1.3	Water consumption and emission .....	167
6.1.3.1.4	By-products and wastes .....	172
6.1.3.1.5	Noise .....	173
6.1.3.1.6	Odour .....	173
6.1.4	Techniques to consider in the determination of BAT .....	173
6.1.4.1	Use of non-carcinogenic raw materials.....	173
6.1.4.2	Penniman-Zoph process to manufacture yellow iron oxide pigments .....	174
6.1.4.3	Fluoride and boron abatement by lime washing .....	175
6.1.4.4	Use of distilled water coming from the evaporation/concentration system for washing pigments .....	176
6.1.4.5	Chromium removal from waste water .....	177
6.1.4.6	Strict control of the pH value of the reaction.....	178
6.1.4.7	Recycling of precipitation sludges back into production .....	178
6.1.4.8	Biological treatment of waste water loaded with nitrates .....	179
6.1.4.9	Pretreatment of waste water loaded with heavy metals .....	180
6.1.4.10	Final treatment of waste water loaded with heavy metals .....	181
6.1.5	Best Available Techniques .....	182
6.1.6	Emerging techniques .....	184
6.2	Phosphorus compounds .....	185
6.2.1	General information.....	185
6.2.1.1	Uses .....	185
6.2.1.2	Toxicity.....	186
6.2.1.3	Explosions and fire hazards .....	186
6.2.1.4	Phosphorus compounds production in Europe and worldwide.....	186
6.2.1.5	Features of the European phosphorus compounds industry.....	187
6.2.1.6	Economics .....	187
6.2.2	Applied processes and techniques .....	187
6.2.2.1	Process chemistry .....	187
6.2.2.2	Production processes .....	187
6.2.2.2.1	Production of $PCl_3$ .....	187
6.2.2.2.2	Production of $POCl_3$ .....	189
6.2.2.2.3	Production of $PCl_5$ .....	190
6.2.2.3	Raw material storage and handling.....	191
6.2.2.4	Finished products storage and handling.....	191
6.2.2.5	Materials used for production equipment .....	192
6.2.3	Consumption and emission levels .....	192
6.2.3.1	Energy consumption .....	192
6.2.3.2	Water consumption.....	192
6.2.3.3	Air emissions .....	192
6.2.3.4	Water emissions.....	193
6.2.3.5	Wastes.....	193
6.2.4	Techniques to consider in the determination of BAT .....	194
6.2.4.1	Use hot condensate water to melt elemental phosphorus and to keep it in liquid form .....	194
6.2.4.2	Use of an inert gas (typically $N_2$ ) to blanket elemental phosphorus raw material .....	195
6.2.4.3	Use of water to blanket the elemental phosphorus raw material and recycling of the water for off-gas scrubbing.....	195
6.2.4.4	Use of elemental phosphorus raw material containing low organic and inorganic impurities .....	196
6.2.4.5	Use of neutral scrubbing for abating $PCl_3$ and phosphorus oxides in waste gases.....	197
6.2.4.6	Use of alkaline scrubbing for abating $PCl_3$ in waste gases .....	197
6.2.4.7	Use of strictly enclosed systems .....	198
6.2.4.8	Incineration of the distillation residues from the $PCl_3$ production.....	198
6.2.4.9	Storage measures for phosphorus compounds .....	199
6.2.5	Best Available Techniques .....	200
6.3	Silicones .....	201
6.3.1	General information.....	201
6.3.1.1	Uses .....	202
6.3.1.2	Toxicology and environmental aspects for the use of silicones.....	202
6.3.1.3	Production capacity .....	203

6.3.1.4	Features of the European silicone industry .....	203
6.3.1.5	Economics .....	203
6.3.2	Applied processes and techniques.....	204
6.3.2.1	Auxiliary chemicals and utilities.....	204
6.3.2.2	Raw materials and auxiliary chemicals storage and handling .....	205
6.3.2.3	Methyl chloride synthesis.....	205
6.3.2.4	Grinding of silicon .....	206
6.3.2.5	Direct synthesis .....	206
6.3.2.6	Distillation.....	207
6.3.2.7	Hydrolysis/condensation or methanolysis .....	208
6.3.2.8	Polymer synthesis.....	209
6.3.2.8.1	Equilibrium polymerisation.....	209
6.3.2.8.2	Polycondensation .....	209
6.3.3	Consumption and emission levels .....	210
6.3.3.1	Raw materials, auxiliary chemicals, energy and water consumption .....	210
6.3.3.1.1	Raw materials and auxiliary chemicals consumption.....	210
6.3.3.1.2	Energy consumption.....	210
6.3.3.1.3	Water consumption .....	211
6.3.3.2	Air emissions.....	211
6.3.3.3	Water emissions .....	212
6.3.3.4	By-products and solid wastes .....	214
6.3.3.4.1	By-products .....	214
6.3.3.4.2	Wastes .....	214
6.3.3.5	Noise .....	214
6.3.4	Techniques to consider in the determination of BAT .....	215
6.3.4.1	Storage of elemental silicon in silos.....	215
6.3.4.2	Optimisation of utility consumption by pinch methodology.....	215
6.3.4.3	Dry dedusting system for elemental silicon grinding, storage and handling.....	216
6.3.4.4	Optimisation of the chemistry for the direct synthesis .....	218
6.3.4.5	Recovery of methyl chloride through condensation with water heat exchangers .....	218
6.3.4.6	Recovery of methyl chloride through condensation using cryogenic fluids .....	219
6.3.4.7	Condensation of methylchlorosilanes by air condensers.....	220
6.3.4.8	Thermal oxidation of off-gases containing light hydrocarbons and chlorinated organic compounds .....	221
6.3.4.9	Treatment of waste water from PDMS production .....	223
6.3.4.10	Minimisation of the quantity of water used in the production process.....	224
6.3.4.11	Re-use of the water formed in the methyl chloride synthesis step into the hydrolysis step.....	225
6.3.4.12	HCl recovery from the hydrolysis of dimethyldichlorosilane .....	226
6.3.4.13	Selection of the elemental silicon particle size.....	227
6.3.4.14	Use of a covered elemental silicon storage .....	228
6.3.4.15	Minimise the source of ignition energy from elemental silicon grinding.....	229
6.3.4.16	Minimise the sources of explosions from elemental silicon grinding and conveying .....	230
6.3.4.17	Cooling of the distillation columns with air .....	231
6.3.4.18	Backup power source for the waste water treatments .....	231
6.3.5	Best Available Techniques.....	232
6.4	Speciality inorganic chemical (SIC) explosives.....	235
6.4.1	General information .....	236
6.4.1.1	Uses.....	236
6.4.1.2	Toxicity .....	236
6.4.1.3	Production capacity .....	237
6.4.1.4	Features of the European SIC explosive industry .....	237
6.4.1.5	Economics .....	238
6.4.2	Applied processes and techniques.....	238
6.4.2.1	Process chemistry.....	238
6.4.2.2	Raw materials and auxiliary chemicals storage and handling .....	239
6.4.2.3	Raw material solution .....	239
6.4.2.4	Reaction .....	239
6.4.2.5	Purification of SIC explosives.....	240
6.4.2.6	Drying of SIC explosives .....	240
6.4.2.7	Handling and storage of SIC explosives .....	240
6.4.3	Consumption and emission levels .....	240

6.4.3.1	Raw materials and auxiliary chemicals consumption .....	242
6.4.3.2	Energy consumption .....	243
6.4.3.3	Water consumption .....	244
6.4.3.4	Air emissions .....	244
6.4.3.5	Water emissions .....	244
6.4.3.6	Solid wastes .....	246
6.4.3.7	Odour and noise emissions .....	247
6.4.4	Techniques to consider in the determination of BAT .....	247
6.4.4.1	Removal of lead from waste waters by precipitation with sulphuric acid or sodium carbonate (pretreatment technique).....	247
6.4.4.2	Removal of traces of explosive materials containing lead from waste waters using a neutralisation station .....	249
6.4.4.3	COD reduction through treatment with activated carbon .....	251
6.4.4.4	Destruction of explosive impurities from waste water .....	252
6.4.4.5	Ground protection .....	253
6.4.5	Best Available Techniques .....	255
6.5	Cyanides .....	257
6.5.1	General information.....	257
6.5.1.1	Uses and markets .....	258
6.5.1.2	Quality of the cyanide products/specifications .....	258
6.5.1.3	Toxicity.....	259
6.5.1.4	Cyanides production in Europe and worldwide .....	259
6.5.1.5	Features of the European cyanide industry .....	260
6.5.1.6	Economics .....	260
6.5.2	Applied processes and techniques .....	261
6.5.2.1	Main types of production processes.....	261
6.5.2.2	Process chemistry .....	262
6.5.2.3	Raw materials and auxiliary chemicals storage and handling.....	263
6.5.2.4	Neutralisation/crystallisation .....	263
6.5.2.5	Filtration .....	264
6.5.2.6	Drying.....	264
6.5.2.7	Compaction.....	264
6.5.2.8	Granulation .....	264
6.5.2.9	Separation from fine dust/sieving/briquetting.....	264
6.5.2.10	Packaging and storing of cyanides.....	264
6.5.2.11	Handling and storage of cyanides.....	265
6.5.3	Consumption and emission levels .....	266
6.5.3.1	Raw materials and auxiliary chemicals consumption .....	266
6.5.3.2	Energy consumption .....	267
6.5.3.3	Water consumption.....	267
6.5.3.4	Air emissions .....	267
6.5.3.5	Water emissions.....	269
6.5.3.6	Solid wastes .....	270
6.5.3.7	Odour and noise emissions .....	270
6.5.3.8	Monitoring.....	270
6.5.4	Techniques to consider in the determination of BAT.....	270
6.5.4.1	Destruction of cyanides from waste gases and waste waters using hydrogen peroxide (H <sub>2</sub> O <sub>2</sub> ) as the oxidising agent.....	270
6.5.4.2	Incineration of process air containing volatile organic compounds (VOCs) .....	273
6.5.4.3	Cleaning-In-Place (CIP) system for equipment contaminated with cyanides.....	275
6.5.4.4	Removal of HCN and NH <sub>3</sub> from waste gases .....	277
6.5.4.5	Returnable packaging for the transport of solid cyanides.....	279
6.5.4.6	Use of a computerised control system to operate the plant.....	280
6.5.4.7	Double containment of cyanide plants.....	281
6.5.4.8	Application of the International Cyanide Management Code (ICMC).....	282
6.5.4.9	Storage measures for solid cyanides .....	283
6.5.4.10	Using NaOH and KOH with a very low content of heavy metals .....	283
6.5.4.11	High level of education and continuous training of personnel .....	285
6.5.5	Best Available Techniques .....	286
6.5.6	Emerging techniques .....	289
<b>7</b>	<b>EMERGING TECHNIQUES.....</b>	<b>291</b>

---

7.1	Decontamination of exhaust gases and waste water by chemically modified inorganic ion exchangers and active carbons .....	291
7.2	Utilisation of industrial waste and especially petrochemical residues for power generation with low emissions .....	292
7.3	Air filtration for the abatement of volatile chromium compounds in the tanning industry ....	293
7.4	Development and application of advanced ceramic electrodes for the electrochemical elimination of cyanides in waste water .....	293
<b>8</b>	<b>CONCLUDING REMARKS .....</b>	<b>295</b>
8.1	Timing of the work.....	295
8.2	Sources of information and development of this document .....	295
8.3	Degree of consensus reached .....	297
8.4	Recommendations for future work.....	297
8.5	Suggested topics for future R&D projects .....	298
	<b>REFERENCES.....</b>	<b>299</b>
	<b>GLOSSARY OF TERMS AND ABBREVIATIONS .....</b>	<b>301</b>
<b>9</b>	<b>ANNEXES .....</b>	<b>309</b>
9.1	Annex I. Questionnaire used to gather environmental information on SIC installations .....	309

---

## List of figures

Figure 2.1: Schematic representation of a SIC production process .....	6
Figure 2.2: Overview of the abatement systems used at a typical SIC installation.....	20
Figure 3.1: Factors on which the type and amount of waste in a typical SIC installation depend.....	39
Figure 4.1: Waste water treatment techniques in relation to contaminants.....	52
Figure 4.2: Main sources of dust and abatement techniques used in the SIC sector.....	70
Figure 4.3: Removal of HCN and NH <sub>3</sub> from waste gases.....	91
Figure 4.4: Incineration of process air containing Volatile Organic Compounds (VOCs).....	94
Figure 4.5: Scrubbing and recycling of cyanides from waste gases and waste waters .....	101
Figure 4.6: A Cleaning-In-Place-system (CIP) of equipment contaminated with solid hazardous compounds .....	106
Figure 4.7: Safety assessment procedure.....	116
Figure 4.8: Iterative assessment strategy for normal operations.....	116
Figure 6.1: Pigment synthesis and processing .....	144
Figure 6.2: Off-gas treatment for reducing total dust from the exhaust gas of a dryer and a miller/grinder .....	148
Figure 6.3: Flow diagram of water effluents treatment.....	150
Figure 6.4: Wet processes for the production of iron oxide pigments and measures for the reduction of emissions .....	152
Figure 6.5: Process steps of aqueous oxidation processes in the production of iron oxide pigments .....	154
Figure 6.6: Production of iron oxide pigments by the Laux process .....	156
Figure 6.7: Production of chromium (III) oxide pigments.....	158
Figure 6.8: Production of Complex Inorganic Coloured (CIC) pigments.....	160
Figure 6.9: Flow diagram for the production of lithopone pigments .....	161
Figure 6.10: Production of phosphorus trichloride by the gas-liquid reaction process.....	188
Figure 6.11: Production of phosphorus trichloride by gas phase reaction .....	189
Figure 6.12: Production of phosphoryl chloride .....	190
Figure 6.13: Production of phosphorus pentachloride .....	191
Figure 6.14: Process steps for the production of silicones.....	205
Figure 6.15: Methyl chloride synthesis.....	206
Figure 6.16: Example of the hydrolysis of dimethyldichlorosilane to oligosiloxane.....	208
Figure 6.17: Consumption of raw materials, auxiliary materials, energy and water for the production of silicones.....	210
Figure 6.18: Emissions to air from the production of silicones .....	211
Figure 6.19: Emissions to water from the production of PDMS.....	213
Figure 6.20: Example of a fabric filter system used in the production of silicones .....	216
Figure 6.21: Chemical structure of some primary explosives.....	235
Figure 6.22: Consumption of raw materials, auxiliary chemicals, energy and water for the production of SIC explosives.....	241
Figure 6.23: Emissions to water from the production of SIC explosives .....	241
Figure 6.24: Basic behaviour of a cyanide solution.....	257
Figure 6.25: Main steps for the production of sodium or potassium cyanide using a water solution process .....	262
Figure 6.26: Emissions to air from the production of cyanides .....	268
Figure 6.27: Emissions to water from the production of cyanides.....	269
Figure 6.28: Destruction of cyanides from waste gases and waste waters.....	271
Figure 6.29: Incineration of process air containing volatile organic compounds (VOCs).....	273
Figure 6.30: Cleaning-In-Place-system (CIP) for equipment contaminated with cyanides .....	275
Figure 6.31: Removal of HCN and NH <sub>3</sub> from waste gases.....	277



---

## List of tables

Table 2.1: Likely environmental impact of the common process steps used in the production of SIC substances .....	7
Table 2.2: Selection of techniques for waste gas emission reduction in relation to the pollutant to be removed .....	21
Table 2.3: Major waste water contaminants and their respective treatment techniques .....	22
Table 3.1: Main pollutants that could be emitted to the air during the production of some SIC substances .....	34
Table 3.2: Pollutants that could be carried by the waste water discharged to the receiving waters in the production of some SIC substances .....	36
Table 4.1: Information breakdown for each technique described in Chapter 4 .....	43
Table 4.2: Operational data associated with the use of precipitation techniques .....	59
Table 4.3: Operational data associated with the use of the adsorption technique .....	64
Table 4.4: Operational data associated with the use of the separator technique .....	71
Table 4.5: Operational data associated with the use of wet dust scrubbers .....	73
Table 4.6: Operational data associated with the use of ESP .....	75
Table 4.7: Operational data associated with the use of fabric and ceramic filters .....	76
Table 4.8: Operational data associated with the use of two-stage dust filters .....	78
Table 4.9: Operational data associated with the use of HEPA filters .....	79
Table 4.10: Operational data associated with the use of HEAF filters .....	81
Table 4.11: Operational data associated with the use of mist filters .....	82
Table 4.12: Operational data associated with the use of membrane separation .....	85
Table 4.13: Operational data associated with the use of condensation .....	86
Table 4.14: Operational data associated with the use of adsorption .....	88
Table 4.15: Operational data associated with the use of wet gas scrubbers .....	90
Table 4.16: Achieved emission levels for the removal of HCN and NH <sub>3</sub> from waste gases .....	91
Table 4.17: Operational data for the removal of HCN and NH <sub>3</sub> from waste gases .....	92
Table 4.18: Achieved emission levels after incineration of VOCs .....	95
Table 4.19: Operational data for the incineration of VOCs .....	95
Table 4.20: Operational data associated with the use of catalytic oxidation .....	96
Table 4.21: Achieved emission levels after SO <sub>2</sub> abatement .....	100
Table 4.22: Achieved emission levels after scrubbing and recycling of cyanides .....	102
Table 4.23: Operational data for the scrubbing and recycling of cyanides .....	102
Table 4.24: Achieved emission levels associated with the CIP of equipment contaminated with cyanides .....	107
Table 4.25: Operational data for the cleaning of equipment contaminated with cyanides .....	107
Table 4.26: Examples from SIC plants for retention volumes .....	110
Table 4.27: Template to analyse the effects due to deviations of chemical processes or to the operation of the plant .....	117
Table 6.1: Main application fields for some inorganic pigments in Western Europe .....	138
Table 6.2: Examples of existing Complex Inorganic Coloured (CIC) pigments .....	140
Table 6.3: Estimated worldwide production of inorganic pigments in 1995 .....	142
Table 6.4: Off-gas treatments for the production of inorganic pigments .....	147
Table 6.5: Main water effluent streams for the production of chromium(III) oxide pigments .....	159
Table 6.6: Sources of waste water from the production of zinc sulphide, lithopone and barium sulphate pigments .....	164
Table 6.7: Consumption of energy at several plants producing SIC pigments in Europe .....	165
Table 6.8: Concentration levels of pollutants measured in the off-gas after treatment at several plants producing pigments in Europe .....	166
Table 6.9: Techniques used to treat waste water at several plants producing pigments in Europe .....	169
Table 6.10: Concentration levels of pollutants measured in the waste water after treatment at several plants producing pigments in Europe .....	170
Table 6.11: Pollutants loads and concentrations for the production of iron oxide pigments .....	171
Table 6.12: Average amount of waste water treated in the production of zinc sulphide, barium sulphate and lithopone pigments .....	172
Table 6.13: Pollutants contained in the waste water from the production of zinc sulphide, barium sulphate and lithopone pigments .....	172
Table 6.14: Emission levels achieved after pretreatment and final treatment of waste water loaded with heavy metals .....	181
Table 6.15: Emission levels associated with BAT 6.1.12 .....	183
Table 6.16: Production capacity of raw siloxanes (i.e. PDMS) in Europe .....	203

Table 6.17: Metal concentrations after sedimentation .....	213
Table 6.18: Possible use of by-products from the production of silicones .....	214
Table 6.19: Main applications of SIC explosives .....	236
Table 6.20: Production capacity of lead azide, lead trinitroresorcinate and lead picrate in Europe .....	237
Table 6.21: Raw and auxiliary materials used in the production of lead azide (LA).....	242
Table 6.22: Raw and auxiliary materials used in the production of lead trinitroresorcinate (LTNR).....	243
Table 6.23: Raw and auxiliary materials used in the production of lead picrate (LP).....	243
Table 6.24: Efficiency of the lead removal pretreatment in the production of lead azide and lead trinitroresorcinate at a Spanish installation .....	245
Table 6.25: Typical concentration of pollutants in waste waters at the output of the central WWTP .....	245
Table 6.26: Annual water emission levels in the production of SIC explosives.....	246
Table 6.27: Concentration values of pollutants in water emissions in the production of SIC explosives.....	246
Table 6.28: Typical quantity of solid wastes generated at a Spanish installation .....	246
Table 6.29: Efficiency of the lead removal pretreatment system at a Spanish installation.....	248
Table 6.30: Technical specifications of the evaporator .....	250
Table 6.31: Example of a daily mass balance .....	250
Table 6.32: Typical liquid cyanide product specifications .....	259
Table 6.33: Sites where sodium cyanide and potassium cyanide are produced in Europe .....	260
Table 6.34: Quantity of raw materials needed to produce one tonne of NaCN and one tonne of KCN respectively .....	266
Table 6.35: Emissions to air from a well operated cyanide production plant .....	267
Table 6.36: Discharge levels to a WWTP from a typical cyanide production plant .....	269
Table 6.37: Achieved emission levels after oxidative destruction of cyanides.....	271
Table 6.38: Operational data for the destruction of cyanides .....	272
Table 6.39: Achieved emission levels after incineration of VOCs .....	273
Table 6.40: Operational data for the incineration of VOCs.....	274
Table 6.41: Achieved emission levels associated with the cleaning of equipment contaminated with cyanides.....	275
Table 6.42: Operational data for the cleaning of equipment contaminated with cyanides .....	276
Table 6.43: Achieved emission levels for the removal of HCN and NH <sub>3</sub> from waste gases .....	277
Table 6.44: Operational data for the removal of HCN and NH <sub>3</sub> from waste gases .....	278
Table 6.45: Emission levels to air associated with BAT for the production of cyanides.....	286
Table 6.46: Discharge levels to water at the inlet of the WWTP associated with BAT for the production of cyanides.....	287
Table 8.1: Milestones for the work on the Speciality Inorganic Chemicals BREF .....	295

## SCOPE

The chemical industry is generally recognised to be a complex industrial sector with an extremely large number and diversity of manufactured products. Some 70000 chemical compounds are manufactured worldwide, each having a distinct chemical nature, production route(s) and end-use [21, European IPPC Bureau, 2003].

For the exercise of the chemical BREFs under the IPPC Directive, the chemical industry was divided into organics and inorganics, and these were then divided into sectors. The four BREF documents covering the production of inorganic chemicals are listed below and Speciality Inorganic Chemicals (SIC) is one of these:

- Chloralkali (CAK)
- Large Volume Inorganic Chemicals – Ammonia, Acids and Fertilisers (LVIC-AAF)
- Large Volume Inorganic Chemicals – Solid and Others (LVIC-S)
- **Speciality Inorganic Chemicals (SIC).**

Together with the other three BREFs, this document is intended to cover the following principal activities that are described in Annex I of the IPPC Directive:

*“Production within the meaning of the categories of activities contained in this section means the production on an industrial scale by chemical processing of substances or groups of substances listed in Sections...*

*4.2. Chemical installations for the production of basic inorganic chemicals, such as:*

*(a) gases, such as ammonia, chlorine or hydrogen chloride, fluorine or hydrogen fluoride, carbon oxides, sulphur compounds, nitrogen oxides, hydrogen, sulphur dioxide, carbonyl chloride*

*(b) acids, such as chromic acid, hydrofluoric acid, phosphoric acid, nitric acid, hydrochloric acid, sulphuric acid, oleum, sulphurous acids*

*(c) bases, such as ammonium hydroxide, potassium hydroxide, sodium hydroxide*

*(d) salts, such as ammonium chloride, potassium chlorate, potassium carbonate, sodium carbonate, perborate, silver nitrate*

*(e) non-metals, metal oxides or other inorganic compounds such as calcium carbide, silicon, silicon carbide*

*4.3. Chemical installations for the production of phosphorous-, nitrogen- or potassium-based fertilisers (simple or compound fertilisers)*

*4.4. Chemical installations for the production of basic plant health products and of biocides*

*4.5. Installations using a chemical or biological process for the production of basic pharmaceutical products*

*4.6. Chemical installations for the production of explosives”*

### Working definition of ‘Speciality Inorganic Chemicals (SIC)’

The term ‘Speciality Inorganic Chemicals’ does not appear in the IPPC Directive, and the Directive does not include any definition of what ‘speciality’ means. Furthermore, the term ‘speciality’ is widely used in the chemical industry but to cover very different realities; **there is no commonly accepted definition of this term, and almost every chemical producer has its own.**

## Scope

Despite this, the term ‘speciality’ is generally understood and used in the chemical industry as opposed to ‘commodity’ or ‘large volume’.

With the view of defining the scope of the SIC BREF and in order to avoid the duplication of information with the LVIC-S BREF (the BREF with the highest probability of overlaps), the following criteria were considered to differentiate SIC substances from LVIC substances (and these were proposed by the European Chemical Industry Council – Cefic):

Criteria	LVIC	SIC
Volume of production*	Usually high	Usually low
Size of investment to build a production plant	Very high	Medium
Product description	Formula	Formula + effect, purity, formulation
Product differentiation from competition	No	Yes – often the speciality product is sold on performance
Applications	Often a large number of applications or very high volume applications	Often only a few applications or highly specialised
Driver for selling to customers	Price	Quality/price
Raw material used	Often a mineral	Often a chemical to be reprocessed and refined
R&D objective	To improve the economics of the process	To create new tailored applications
Integration of production	Vertical, often produced at the source of the mineral raw material	Often produced on an LVIC site as a complementary production
Who makes the buying decision?	The customer’s purchasing department	The customer’s technical/production staff

\* UBA proposed an indicative threshold of 100 kt/yr

Each individual speciality inorganic chemical addressed in this document meets several of the above criteria, but not necessarily all of them.

For the purpose of this document, the following definition of SIC is used:

*‘For the purpose of the SIC BREF, Speciality Inorganic Chemical (SIC) is taken to mean an inorganic substance manufactured industrially, by chemical processing, generally in relatively small quantities, according to specifications (i.e. purity) tailored to meet the particular requirements of a user or industry sector (e.g. pharmaceutical).’*

Generally, the SIC sector is considered to have the following features:

- companies of all sizes manufacture SIC substances
- SIC substances are produced in medium and small sized facilities
- SIC substances are produced in standalone installations or in installations that are part of a larger industrial (typically chemical) complex
- a SIC facility can be dedicated to the production of a single SIC product or several SIC substances
- continuous as well as batch operations are used for the production of SIC substances
- confidentiality is an issue for companies producing SIC substances
- the production of SIC substances often requires the purification of products and advanced developments to cope with customers’ new requirements.

Bearing in mind the number and huge variety of SIC substances, associated raw materials and production processes, it was considered that a good approach was to focus, as a starting point, on a limited number of families or groups of SIC substances, and to develop BAT conclusions for each of these families. From this, generic or common BAT conclusions that could apply to the production of a wider range of SIC substances not specifically covered by the selected families of SIC substances have been concluded.

The following criteria were adopted in order to select the families of substances that are discussed in this document:

- the family is of industrial importance (relatively large production volume and/or relatively large number of manufacturing facilities)
- the manufacturing processes for the family have environmental issues where an information exchange will be particularly valuable
- information will be readily available on the manufacturing processes so that the SIC BREF work could be completed within a reasonable timeframe.

The following six families were selected using the above-mentioned criteria:

- speciality inorganic pigments
- silicones
- phosphorus compounds (PCl<sub>3</sub>, POCl<sub>3</sub>, PCl<sub>5</sub>)
- inorganic explosives
- cyanides (NaCN, KCN)
- soluble inorganic salts of nickel (NiSO<sub>4</sub>, NiCl<sub>2</sub>, NiCO<sub>3</sub>, Ni(NO<sub>3</sub>)<sub>2</sub>).

### Document structure

As the scope of SIC is so large, this document contains a mixture of generic/common information and specific/illustrative information that is presented in two parts:

<b>Part A</b>	<p><b>Generic/common part</b> General information on the SIC sector. Common process steps, abatement systems, energy supply, process equipment and infrastructure that are generally valid for all SIC production processes or common to many SIC production processes. <b>Conclusions on generic BAT are drawn.</b></p>	<p><b>Chapter 1</b> <b>Chapter 2</b> <b>Chapter 3</b> <b>Chapter 4</b> <b>Chapter 5</b></p>
<b>Part B</b>	<p><b>Specific/illustrative part</b> Specific information on a small number of selected 'illustrative SIC families' to demonstrate the application of BAT in the SIC sector. These illustrative families have been chosen according to the criteria indicated above. <b>Specific BAT conclusions are drawn for each family.</b></p> <p>The illustrative SIC families are:</p> <ul style="list-style-type: none"> <li>• speciality inorganic pigments</li> <li>• phosphorus compounds</li> <li>• silicones</li> <li>• inorganic explosives</li> <li>• cyanides.</li> </ul> <p>The exchange of information on soluble inorganic salts of nickel could not lead to drawing BAT conclusions specific to this family. For this reason, there is no specific section in this document covering soluble inorganic salts of nickel.</p>	<p><b>Chapter 6</b></p> <p>Section 6.1 Section 6.2 Section 6.3 Section 6.4 Section 6.5</p>

Noting the introduction of BAT given in Chapter 5, BAT for the production of a speciality inorganic chemical pertaining to one of the illustrative SIC families described in this document is the combination of the generic elements presented in Chapter 5 and the specific elements that can be found in the relevant Section 6.X.5 (i.e. Section 6.1.5 for speciality inorganic pigments, Section 6.2.5 for phosphorus compounds, Section 6.3.5 for silicones, Section 6.4.5 for inorganic explosives and Section 6.5.5 for cyanides). Concerning the production of a SIC substance that does not pertain to one of the illustrative SIC families addressed in this document, only the generic elements presented in Chapter 5 are relevant to define BAT.

Users of this document should find that moving from Part A to Part B of this document provides an increasing level of detail and a trend from qualitative to quantitative information. A detailed description of BAT, and associated consumption/emission levels, is only presented for those families described in Part B, although Part A (in Chapter 5) gives generic/common BAT for the SIC sector, and, as far as possible, consumption and emission levels associated with BAT.

When considering permit conditions for a plant producing chemicals pertaining to one of the illustrative families, Part B provides specific information on production techniques, consumption and emission levels, process-integrated and end-of-pipe techniques, and BAT. When permitting any other SIC processes, then the information in Part A provides a toolkit that can be used to formulate permit conditions.

### **Interface with other BREFs**

There are other BREFs in the planned series that may need to be read in conjunction with this document in order to determine BAT for SIC processes. The relevant BREFs include ‘horizontal BREFs’ (that cover issues common to several industrial sectors or subsectors – e.g. Emissions from Storage) and vertical BREFs (that cover a particular industrial sector – e.g. Large Combustion Plants). At the time of writing, there are BREFs on the following topics that may be pertinent to the SIC sector:

- Common Waste Water and Waste Gas Treatment/Management Systems in the Chemical Sector [8, European IPPC Bureau, 2003]
- Emissions from Storage [31, European IPPC Bureau, 2000]
- Industrial Cooling Systems [36, European IPPC Bureau, 2003]
- Monitoring of Emissions [37, European IPPC Bureau, 2003]
- Economics and Cross-Media Effects [32, European IPPC Bureau, 2004]
- Large Combustion Plants [34, European IPPC Bureau, 2004]
- Waste Incineration [35, European IPPC Bureau, 2004]
- Waste Treatments [29, Cefic, 2004].

This document aims to minimise any overlaps with the relevant horizontal BREFs, but may cover horizontal topics in a greater level of detail. Horizontal BREFs are cited in this document for the sake of completeness/understanding and to alert readers to the existence of complementary information.

## 1 GENERAL INFORMATION

### 1.1 The chemical industry in Europe

[29, Cefic, 2004]

In 2002, the world's production of chemicals was estimated at EUR 1841000 million. With EUR 527000 million in 2002, the EU-15 is the largest chemical producing area in the world, followed by the US and Asia (excluding Japan and China). Taken together, these three regions account for nearly three quarters of the world's production.

In 2002, the EU-15 was the world's leading exporter and importer of chemicals accounting for half of global trade. The key trading regions are the EU, Asia, and North America.

Germany is the largest producer of chemicals in Europe, followed by France, Italy and the UK. Together, these four countries produce 64 % of EU-15 chemicals output. Adding Belgium, Spain, the Netherlands and Ireland raises the share to nearly 93 %.

Over the years 1992 to 2002, chemical production (4.7 %) grew more quickly than apparent consumption (3.9 %). The growth rate of exports (11.4 %) exceeded that of imports (10.1 %); the trade surplus increased over time.

### 1.2 The SIC sector in Europe

Although there is no common definition for the chemical industry across countries (as an example, fibres can be either included or excluded), the European chemical industry can be broken down into several sectors, for example:

- petrochemicals
- organic commodities
- plastics and synthetic rubber
- industrial gases
- fertilisers
- pharmaceuticals
- consumer chemicals (i.e. perfumes and cosmetics, soaps and detergents)
- **speciality and fine chemicals.**

The Speciality Inorganic Chemicals (SIC) sector, as defined for the purpose of this document (see Scope section above), would essentially be part of the larger speciality and fine chemicals sector (it may also cross into the pharmaceuticals sector) which represented around 29 % of the total chemical industry sales in Europe in 2002 [29, Cefic, 2004]. It is thought that, in Europe, the SIC sector represents between 10 and 20 % of the total chemical industry sales, and that sales are increasing slightly.

### 1.2.1 Production and market features

Speciality Inorganic Chemicals are, in general, produced in smaller volumes (typically from a few tonnes to 100 kilotonnes per year) and sold with a higher profit margin than commodity or bulk chemicals, although this may vary widely for different types of speciality chemicals (high margins have eroded for the long established SIC substances). SIC substances tend to be more consumer orientated and less subject to cyclical demand.

Production of SIC in Europe is generally highly automated and computer-controlled (although this is not generally the case for the production of SIC explosives and pigments).

A SIC substance is often produced in several grades and forms (e.g. powder, granules, paste, solution) depending on the customers needs.

The geographical distribution of installations producing SIC is thought to follow the general distribution of the European chemical industry with Germany being the largest manufacturer of SIC, followed by France, Italy and the UK. This situation may vary significantly when a specific sector of the SIC industry is considered. As an example, SIC pigments are mainly produced in Germany, Italy and Spain.

SIC substances are sold to companies, either other chemical companies or non-chemical companies, serving an immense range of end user markets, on either a specification of purity or on their availability to deliver a particular effect. Typical major end user markets are pharmaceuticals, medicine, ceramics, electronics, photography, coatings, plating, battery, crop protection, paints and inks.

### 1.2.2 Companies' profiles

European SIC manufacturers range in size from very small (<10 staff) to very large, multinationals (>10000 staff), with typical SIC manufacturing installations having between 60 and 250 staff. Large companies embarked into the SIC business as revenues from commodity chemicals started to diminish due to increasing competition and as a way to generate higher revenues. Large chemical companies generally own subsidiaries dedicated to the production of SIC.

The SIC sector covers a wide range of enterprises: on one side, there are small enterprises processing few (sometimes single) products and on the other side there are enterprises producing multiple SIC products.

SIC installations are small to medium sized installations that may be part of a larger industrial (typically chemical) complex in particular to benefit from raw and auxiliary materials produced on such a site, or may be standalone, independent installations. Depending on the substance(s) produced and on the market demand, SIC are produced either batch wise (e.g. inorganic explosives) or in a continuous mode of operation (e.g. silicones, nickel salts).

SIC installations can be found at, or close to, metal refining sites, metals being important raw materials for the production of SIC (e.g. metal salts). Some SIC production processes can even be completely integrated in the metal production site.

What is important for SIC companies is the smaller size of the individual markets of speciality chemicals, the greater importance of service as a criterion for purchasing, the currently smaller maximum size of the companies as well as the greater variety of speciality companies. This represents a simple consequence of the greater variety of products and of the area of application of the specialities as compared with the basic chemicals [47, Dr Pflug, 2003].



### 1.2.3 Sector's outlook

SIC companies generally focus on the development of niche markets. There is probably a higher degree of business risk attached to this policy, as external shocks may have more serious repercussions when production is concentrated to serve a limited number of customers.

The SIC sector's outlook has become grim. Speciality chemical companies have taken on high levels of debt to finance acquisitions made at top-of-the-market prices. Also, many speciality products have turned out to have margins no better than commodity products as a result of higher production (e.g. higher research and development costs as well as laboratory costs) and service costs.

However, recent changes in the operating structures of the companies and the focus on core businesses should enable them to compete strongly in domestic and global markets. International trading, in volume and in value terms, is forecast to increase and growing prosperity around the world is expected to generate a greater demand for SIC substances.

Pressure to adapt to the demand of customers is especially high for SIC producers serving industries producing goods with short life-cycles such as the electronics and battery sectors.

In Western Europe, the trend towards developing speciality chemicals is forecast to intensify to avoid direct competition from chemical producers in the developing countries. More emphasis will be placed on serving higher value niche markets, but, to be successful, companies supplying niche markets will require greater expenditure on research and development (R&D) [46, Research and Markets, 2001].

### 1.2.4 Competition

The Speciality Inorganic Chemicals sector is highly competitive and confidential in nature as companies tend to develop niche markets and focus on their competitive advantages.

Until recently, Asia's strength was as a low cost producer of bulk chemicals. However, companies in Asia (especially China and India) have become much more efficient at making complex speciality products in the last few years. Furthermore, companies in Asia are growing at a much higher rate than companies in Europe.

Competition in the SIC sector is generally based on quality as opposed to price (although this is not the case in the inorganic pigments industry), so there is less sensitivity to changes in appreciation of currencies (e.g. EUR/USD) and export sales are generally not considerably affected by such changes.

Although labour costs are an important factor for the SIC sector, assets and proximity to customers may be more important. If this is the case, European companies may not be at a disadvantage compared to their Asian competitors.

### 1.3 Key environmental issues in the SIC sector

The SIC sector (see Section 1.2) comprises a large number of installations with relatively few common factors producing thousands of different chemicals, so that any substance might conceivably be a potential release to any medium (i.e. air, water, soil).

In spite of this situation, a few common general environmental issues can be identified for the SIC sector as a whole:

- **emission of particulates to air** (mainly dust and dust containing heavy metals)
- NO<sub>x</sub> emissions
- **waste waters with high COD, heavy metal and/or salt** (e.g. chlorides, sulphates, nitrates, carbonates, sulphides, hypochlorites) **loads**
- solid wastes containing heavy metals
- vapours of volatile liquid substances
- consumption of energy
- consumption of water.

Generally, only some of these issues are relevant to individual SIC installations.

The enormous variety of possibly produced and handled (also emitted) substances at SIC installations can also include highly harmful compounds having toxic or carcinogenic properties (e.g. cyanides, cadmium, lead, chromium (VI), arsenic). In addition, there are explosives among SIC substances (see Section 6.4). Health and safety can therefore be a crucial issue in the production of SIC substances.

## 2 COMMON APPLIED PROCESSES AND TECHNIQUES

### 2.1 General features of a SIC production process

Although processes for the production of SIC are extremely diverse and sometimes very complex (e.g. silicones), they are typically composed of a combination of simpler activities (or process steps) and equipment. The common activities and equipment are combined and modified to create the chemical process for production of the desired speciality product. Some of the common activities have already been recognised through the preparation of horizontal BREFs (e.g. for cooling systems, bulk storage, waste water and waste gas treatment/management systems).

The core activity of a chemical production process is the conversion of raw materials into the desired product(s) using the necessary chemical reactions and physical changes. This typically involves the five general stages described below and shown schematically in Figure 2.1.

- **raw and auxiliary materials supply, storage, handling and preparation<sup>1</sup>**: the supply, storage and handling of the raw and auxiliary materials, their preparation (e.g. weighing, mixing) and their charging into the vessel(s) where the chemical reaction(s) will occur (e.g. reactor, kiln)
- **synthesis/reaction/calcination**: the core of every process where raw materials are transformed into a crude product by means of a chemical reaction, often with the aid of a catalyst
- **product separation and purification**: the product obtained from the reaction is separated (sometimes in several steps) from other reaction components (e.g. unreacted raw materials, by-products, catalysts) and purified (sometimes in several steps) to the required specification
- **product storage and handling**: the storage, packaging and export of the finished products
- **emissions abatement**: the collection, re-use, treatment and disposal of unwanted gases, liquids and solids containing those pollutants that have not been addressed by process-integrated measures.

It is important to highlight that in the SIC sector, the quality and purity of raw materials are key factors influencing the environmental impact of the substances produced. It can be noted that there are sometimes opportunities to re-use/recycle into the SIC production process (or in other processes within the industrial site where the SIC installation is located) residues generated particularly in the 'synthesis/reaction/calcination' and the 'emissions abatement' steps. This is exemplified in the family of SIC substances addressed in Chapter 6 of this document (see also Figure 3.1).

The five general stages above are complemented by:

- a comprehensive **infrastructure** that interconnects the process steps (e.g. cooling systems, vacuum systems, safety systems and facilities)
- an **energy** system that produces steam or electrical energy for use in the process, and cooling facilities (where needed)
- a **management system** that ensures the control of the process under all scenarios (e.g. normal operation, emergencies). This can be viewed as the software to make all the hardware work.

---

<sup>1</sup> Preparation may include purification of the raw material.

As this document does not provide a comprehensive description of all SIC processes, it is important to understand the generic principles of process steps, site infrastructure, energy, and management systems. These fundamental elements should enable a basic understanding of any SIC production process, its potential environmental impact, and suitable techniques in particular for preventing and controlling emissions. The following sections in this chapter therefore describe, in a generic manner, the main features of these fundamentals as applied to the production of SIC. More detailed descriptions of chemical processes and equipment can be found in a standard textbook such as the Ullmann's Encyclopedia of Industrial Chemistry [1, Ullmann, 2001].

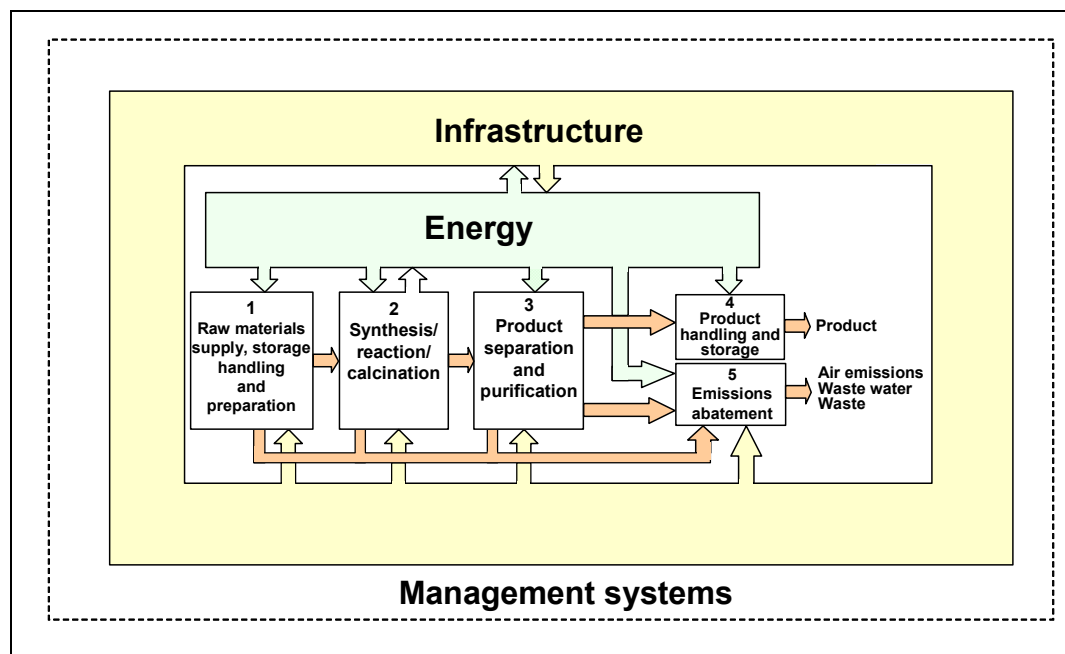

Figure 2.1: Schematic representation of a SIC production process

## 2.2 Common process steps

The large majority of processes used to produce SIC substances are composed of a combination of a limited number of process steps (Table 2.1). These process steps concern either the type of chemical reaction that are used to produce SIC or deal with the physical transfer of energy and materials between the six possible combinations of state (i.e. gas-gas, gas-liquid, gas-solid, liquid-liquid, liquid-solid, solid-solid).

Table 2.1 presents the likely environmental impact of the common process steps used in the production of SIC substances.

This section does not present all possible process steps that can be found in the production of SIC substances, but only those that are used to such an extent that they have been considered 'common' in the framework of the elaboration of this document.

Common process step	Example of SIC substances produced						Likely environmental impact				
	Pigments	Phosphorus compounds	Silicones	Explosives	Cyanides	Nickel salts	Consumptions		Emissions		
							Energy	Water	Air	Water	Waste
Dissolution of raw materials	X			X			X	X			X
Mixing	X						X		X		
Synthesis/reaction	X	X	X	X	X	X	X	X	X	X	X
Calcination	X						X		X		
Washing	X		X	X		X		X		X	X
Drying	X			X	X	X	X		X	X	
Dry milling/grinding	X						X		X		
Wet milling	X						X	X		X	
Sieving					X		X		X		
Condensation		X	X				X		X	X	
Distillation		X	X				X		X	X	X
Evaporation						X	X			X	
Filtration					X	X					
Hydrolysis			X					X	X	X	
Extraction						X					
Compaction					X		X		X		
Granulation					X		X		X		
Briquetting					X		X		X		

**Table 2.1: Likely environmental impact of the common process steps used in the production of SIC substances**

## 2.2.1 Dissolution of raw materials

### Description

[1, Ullmann, 2001]

Depending on the production process used to manufacture a SIC substance, solid raw materials may need to be put in solution, without chemically changing them, in order to separate the non dissolving parts and to be further processed (e.g. for the production of speciality inorganic pigments and SIC explosives). This is carried out by dissolving, suspending, dispersing, emulsifying, etc. the solids in a solvent (generally liquids at room temperature and atmospheric pressure – e.g. water in the production of inorganic explosives). For the production of SIC substances, water is the most commonly used solvent.

During dissolution, the solvent acts on the substance to be dissolved to increase its state of distribution. Dissolution proceeds at a finite rate which depends on the specific surface area of the substance to be dissolved, its degree of crystallisation, its rate of diffusion into the solvent, and on the temperature. Often a substance is considered to be sparingly soluble if its rate of dissolution is low. Most dissolution processes are endothermic and are thus promoted by a temperature increase.

### **Environmental issues**

Energy: energy may be used in the form of heat or kinetic energy in the dissolution operation.

Water: in the production of SIC, the main environmental issue associated with the dissolution of raw materials is the consumption of fresh water. Waste water can sometimes be used as a substitute for the use of fresh water.

Waste: waste may be generated in the dissolution of raw materials.

### **2.2.2 Mixing**

#### **Description**

[1, Ullmann, 2001]

Mixing operations can be classified according to the aggregate state of the predominant component (i.e. gaseous, liquid, paste, solid/granular). For liquids, mixing is usually referred to as 'stirring' and for pastes, mixing is usually referred to as 'kneading'.

Coarse mixing in mixers for solids is accomplished by the continuous movement of material in the process volume. It must be possible for adjacent particles to change places. Depending on the flowability of the powders being mixed, this can be achieved through a variety of mechanisms and in a variety of geometries.

The large number of mixers on the market can be classified under several headings:

- tumblers
- screw mixers
- paddle mixers
- pneumatic mixers
- silo mixers
- high speed mixers.

Mixing of solid components is an important process step in the production of SIC pigments.

#### **Environmental issues**

Air: the mixing of solid fine materials (powder) can generate dust that can be emitted to air. Mixing equipment can be totally or partially enclosed or dust capture systems can be installed on top of mixing equipment in order to minimise diffuse emissions. The ducted dust can be led to an abatement system (e.g. bag filter) to minimise emissions to air.

Energy: energy is used in the mixing operations to power equipment (e.g. motors).

Noise: mixing involves the use of mechanical equipment which produces noise.

### 2.2.3 Synthesis/reaction

#### Description

Synthesis, or reaction, is the core of the production process, as this is where raw materials are transformed into a crude product by means of a chemical reaction (e.g. precipitation), often with the aid of a catalyst in order to increase the production efficiency. The reaction takes place in a reactor (see Section 2.6.1 for the description of a reactor and the associated environmental issues). A synthesis/reaction or a calcination process step is always needed for the production of a SIC substance.

#### Environmental issues

Air: emissions to air may arise from the synthesis/reaction operations. VOC or dust emissions can be produced.

Water: waste waters may arise from the synthesis/reaction operations.

Energy: the reaction can necessitate the use of energy to heat or cool the reactor.

Resource: often a catalyst is needed to foster the reaction and reach higher production efficiencies.

Wastes: synthesis/reaction can generate residues (e.g. catalysts residues, non-reacted products).

Safety: safety may be an issue to consider in synthesis/reaction, especially when the operation involves the use of hazardous compounds. Specific measures may be necessary to meet the requirements of the Seveso II Directive (Directive 96/82/EC) in particular.

### 2.2.4 Calcination

#### Description

Calcination is an endothermic process that requires heat to decompose chemical compounds. A calcination process step is used in the production of some speciality inorganic pigments (see Section 6.1.2.1.2).

Combustion processes involve exothermic oxidation or 'burning' of the feed material. Roasting processes use elevated temperatures and controlled furnace atmospheres to effect the desired chemical reactions in the furnace charge; roasting reactions may be either endothermic or exothermic. Although many furnace technologies exist, current industrial practice favours the rotary kiln and the fluidised-bed reactor for these applications.

A rotary kiln is an inclined, rotating cylindrical reactor through which a charge moves continuously. In a fluidised-bed reactor used for calcination purposes, an initially stationary bed of solid particles is brought to a 'fluidised' state by an upward stream of gas as soon as the volume flowrate of the fluid exceeds a certain limiting value.

#### Environmental issues

Air: in the calcination process, some products of decomposition can be emitted to the air, e.g. CO<sub>2</sub>, SO<sub>x</sub>, NO<sub>x</sub>, VOCs, particulates (dust). Dust is emitted from the calcination of pigments and needs to be abated. During the calcination of lithopone pigments, sulphur dioxide is liberated and needs to be abated.

Energy: calcination requires the consumption of energy.

## 2.2.5 Washing

### Description

Washing is often used for eliminating soluble by-products (e.g. salts), e.g. from the production of SIC pigments (see Section 6.1.2.2), and is usually subsequent to the synthesis/reaction or calcination step. In the production of SIC substances, washing is usually performed with water (occasionally, organic solvents may be added to minimise organic impurities, as in the case of the production of SIC explosives – see Section 6.4.2.5)

### Environmental issues

Water: the amount of water used is an issue. The waste waters are usually heavily loaded with by-products (e.g. salts).

## 2.2.6 Drying

### Description

[1, Ullmann, 2001]

Drying denotes the separation of volatile liquids from solid materials by vaporising the liquid and removing the vapour. The liquid that is to be removed in the production of SIC is usually water, but it could also be a solvent such as alcohol or acetone, or a mixture of such solvents.

The vaporisation of liquids requires the supply of heat. The product that is to be dried is denoted as the moist solid (e.g. moist cyanide crystals), or simply as the solid. The substance that carries the necessary heat is called the drying agent. This substance could be air, an inert gas, or superheated steam. Heat could also be supplied by radiation, by hot surfaces, or by microwaves.

The myriad of dryer types is a consequence of the different behaviour that the solid exhibits during drying, the particular product needs, and many economic considerations.

The main types of dryers used in the SIC sector are:

- spray dryers
- fluidised-bed dryers
- rotary dryers
- static tray dryers (room dryers). Because safety issues do not permit the use of spray, fluidised-bed, or rotary dryers in the production of SIC explosives, static tray dryers are used (see Section 6.4.2.6).

Because drying may cause particles to be lumped together, a subsequent milling operation may be required to obtain the required fine particle size (e.g. in the production of speciality inorganic pigments or in the production of soluble inorganic salts of nickel).

Drying is very much used in the production of SIC substances (e.g. speciality inorganic pigments, SIC explosives, cyanides, soluble inorganic salts of nickel).

### Environmental issues

Air: drying processes are potential sources of dust and VOC emissions.

Energy: the heat supply implies the consumption of energy (electricity or steam).

Water: drying may generate waste water.



## 2.2.7 Size reduction and separation operations

Size reduction, also known as comminution, is defined as the mechanical breakdown of solids into smaller particles without changing their state of aggregation. Processes such as the atomisation of liquids or the separation of gas into bubbles are not considered here. The main objective of size reduction in the SIC sector is the production of a specified particle size distribution or a specific surface area.

Size reduction equipment cannot be operated without auxiliary devices, such as:

- bunkers
- feeders
- feed control and conveying equipment
- ventilators
- pipes
- classifiers
- dust separators.

Sections 2.2.7.1, 2.2.7.2, 2.2.7.3 present the main size reduction operations used in the production of SIC substances and their associated environmental impact.

### 2.2.7.1 Dry milling/grinding

#### Description

Dry milling/grinding is the process of reducing materials to fine powder or to small particles in a suitable mill without the presence of a liquid, either by rods, balls, or pebbles, or autogenously, by the material itself. Dry milling/grinding is used if the subsequent process is a dry process or if the substance is intolerant to water or other liquids. With respect to workers safety, attention must be paid to the risk of explosions (dust explosion).

Dry milling/grinding is used for example in the production of speciality inorganic pigments (see Section 6.1.2 and Figure 2.1).

#### Environmental issues

Air: dry milling/grinding processes are potential sources of dust emissions. Dust (in particular dust containing heavy metals) is emitted for example in the production of SIC pigments and need to be abated (see Figure 6.2).

Energy: consumption of electricity to power the motors.

Noise: dry milling/grinding involves the use of mechanical equipment which produces noise.

Safety: dry milling/grinding may involve risks of explosion (dust explosion, see Section 6.3.4.16).

### 2.2.7.2 Wet milling

#### Description

[1, Ullmann, 2001]

Wet milling/grinding is defined as the comminution (reducing to fine powder or to small particles of materials) of solids suspended in a fluid. The principal reasons for using this technique are:

- the feed is already in the form of a suspension
- the product is desired as a suspension
- the feed material has to be finely ground and has a tendency to agglomerate
- the material is toxic.

Wet milling/grinding combines the actual comminution of the solid particles with the breaking up of agglomerates and the dispersion of the individual particles. In some machines, comminution is the primary objective, whereas in others deagglomeration is the primary function.

Comminution devices, with the exception of crushers, impact mills, and jet mills are used for wet grinding. They operate primarily with low to moderate viscosity suspensions. However, roller and high compression roller mills can only be employed at moisture levels of 20 % or less; although some roller mills are made for wet milling. The Szego mill, the roller frame, the agitated ball mill, perl mills, and the disk mill have been especially designed for wet milling.

Wet milling is used, for example, in the production of speciality inorganic pigments (see Section 6.1.2 and Figure 2.1).

#### Environmental issues

Energy: energy is used in the wet milling operations to power equipment (e.g. motors).

Water: the fluid used in wet milling is usually water. Waste water originates from wet milling operations.

Noise: wet milling involves the use of mechanical equipment which produces noise.

### 2.2.7.3 Sieving

#### Description

This operation involves passing the particle materials through openings of a particular standard size in a screen in order to make them smaller. Different types of sieving operations exist:

- gravity sieving
- mechanical sieving
- vacuum sieving
- air classifying.

Sieving is used, for example, in the production of cyanides (see Section 6.5.2.9).

#### Environmental issues

Air: sieving processes are potential sources of dust emissions.

Energy: energy is used in the sieving operations to power equipment (e.g. motors).

## 2.2.8 Condensation

### Description

Components from gaseous mixtures can be separated into liquids (or solids) by fractional condensation. Either the residual gas or the condensate may be the desired product. The temperature, the partial pressure of the condensing substances and their vapour pressure are linked. The recovery of 100 % of the condensing substances is not possible, whatever the temperature, when inerts are present with the condensing substances. Condensation may be used to separate products from waste water or waste gas streams and this often enables valuable feedstock or solvent to be returned to the production process. Condensation of volatile species is also used to minimise the emission of air pollutants, but this may require the use of cryogenic condensation to achieve the desired lower emissions.

Condensation processes are used, for example, in the production of silicones (see Section 6.3.2.6) and phosphorus compounds (see Section 6.2.2.2, Figure 6.10 and Figure 6.11).

### Environmental issues

Air: residual components that are not condensed can be emitted to the air.

Water: if the residual gas is the product, condensation will generate waste water. Cooling water may be used.

Energy: considerable amounts of energy may be required in the condensation operations.

Wastes: residual condensate can be a waste.

## 2.2.9 Distillation

### Description

Distillation is the most important industrial method of separating liquids through differences in their boiling points. Distillation involves the partial evaporation of a liquid phase followed by condensation of the vapour. This separates the starting mixture (the feed) into two fractions with different compositions; namely a condensed vapour (the condensate or distillate) that is enriched in the more volatile components and a remaining liquid phase (the distilland) that is depleted of volatiles. Distillation can be divided into sub-categories according to:

- operating mode (continuous or batch)
- operating pressure (vacuum, atmospheric or pressurised)
- number of distillation stages (single or multistage)
- introduction of inert gases
- use of additional compounds to aid separation (azeotropic and extractive distillation).

Only a limited number of separation problems may be solved by simple distillation and it is unsuitable for feeds containing components with similar boiling temperatures. Multistage distillation is used, for example, in the production of silicones (see Section 6.3.2.6).

A higher efficiency can be achieved by increasing the contact surface area of the liquid and vapour phases. Rectification columns provide intensive mass transfer by the repeated countercurrent contacting of the vapour and liquid streams in multiple stages. Rectification columns are of the plate or packed design, and may involve more than 100 distillation steps. The internal structure provides a large mass transfer contact surface which is constantly regenerated. The mass transfer contact area is maximised by ensuring that the column packing is completely wet. Heat is required at the bottom of a distillation column for evaporating the feed and condensation energy is needed at the top of the column. The condensation energy is often transferred into cooling water or air, and this may provide an opportunity for energy recovery.

### **Environmental issues**

Distillation columns may contribute to emissions in three ways:

- by allowing impurities to remain in the product
- through polymer formation in the still due to an excessive temperature
- by inadequate condensing.

Air: off-gases from distillation may contain volatile material in the form of vapour or entrained droplets/mist, although this can be reduced by the use of additional condensing areas. Non-condensable substances (e.g. oxygen, nitrogen, carbon dioxide, low boiling organics) are not usually cooled to their condensation temperature and will exit the condenser. Emission points from distillation are typically: the condenser, accumulator, hot wells, steam jet ejectors, vacuum pumps and pressure relief valves. The total volume of gases emitted from a distillation operation depends upon: air leaks into the column (increases with reduced pressure and increased size); volume of inert carrier gas; gases dissolved in the feed; efficiency/operation of the condenser or other recovery equipment; and physical properties of the organic constituents.

Water: depending on the boiling point of the components, effluents may result from aqueous bottom residues or from the top after condensation. Discharges depend on the efficiency of the distillation process and of additional steps for phase separation (preferably fractionated-condensation of the top effluent and stripping of the bottom residues).

Wastes: highly concentrated still bottoms are often incinerated if recovery is not possible.

Energy: both the heat supply needed to evaporate the liquid phase, and the cold supply to condensate the vapour in the top of the column, imply the consumption of energy which may be very high. When batch distillation is used, the total energy supply could be minimised through optimal selection of reflux-time policies in industrial practice.

## 2.2.10 Evaporation

### Description

[1, Ullmann, 2001]

Solutions consisting of a solvent and a dissolved solid substance may undergo simple thermal separation by vaporising the solvent, thus concentrating the residual solid. This is a result of the small vapour pressure of most solid components. This method plays an important part in the recovery of many common materials, for example salts (e.g. inorganic salts of nickel) and the like. Evaporation may also serve the purpose of separation and recovery of the pure solvent. It is also possible to use evaporation to concentrate emulsions and suspensions. Usually, the term 'vaporisation' is used when the predominant purpose is recovering the solvent and the term 'evaporation' when the task is separating the solid or increasing its concentration.

In designing evaporation plants, particularly in the choice and design of the equipment, a series of points needs careful consideration: chiefly among these, is the operational behaviour of the materials being processed, for example, any tendency towards forming deposits and fouling the heating surfaces, or the residence time of thermally unstable products.

Because of their low thermal efficiency, simple single-stage evaporators are seldom used. Their application is limited to systems of small capacity or those in which the product requires short solution residence times due to temperature sensitivity.

Multistage evaporation (or cascade evaporation) is an effective means for reducing steam consumption. A number of evaporator stages are connected together in such a manner that the solvent vapours generated in one stage serve as the heating medium for a succeeding stage. Also, only the vapours generated in the last stage must be condensed by a cooling medium, thus reducing cooling water usage.

Vapour recompression evaporation is a heat pumping technique. A portion, or the total flow of solvent vapour leaving the evaporator vapour separation chamber, is compressed to a higher pressure and condensed in the steam chest of the same evaporator. In many cases, this processing scheme achieves specific heating steam efficiencies that can only be attained by multistage evaporator systems having as many as three to five stages.

### Environmental issues

Air: evaporation is a potential source of air emissions.

Water: the evaporation operations can generate waste waters if vapours are condensed.

Energy: energy consumption may be very high in the evaporation operations.

## 2.2.11 Solid-liquid and solid-gas separations

### Description

Solid-gas and solid-liquid separations have industrial importance for SIC product finishing and for minimising emissions of particulate matter to the air. Product finishing applications include separating heterogeneous catalysts from a product stream or separating solid products, by-products or intermediates.

The principal solid-gas separation techniques are:

- cyclones
- fabric filters
- ceramic filters
- electrostatic precipitators (ESP)
- scrubbers.

The main solid-liquid separation techniques are:

- centrifuging
- filtration
- sedimentation and clarification
- drying (see Section 2.2.6).

The choice of technique depends on:

- the characteristics of the particles and the carrier stream
- process factors such as temperature and pressure
- the volume of the carrier stream and the concentration of particles in it to be treated
- which stream is 'product' and which is 'waste'
- operational factors such as floor space and headroom
- economic factors (investment and operational costs).

### Environmental issues

Air: in case the end-product is not the gas, emissions into the air are released when using the above-mentioned techniques (e.g. fabric filters, ESP) for solid-gas separation.

Wastes: it is often possible to re-use solids that are collected by separating devices, although often for lower grade applications.

### 2.2.12 Hydrolysis

[1, Ullmann, 2001]

#### Description

Hydrolysis of compounds usually results in the introduction of a hydroxyl function and is most commonly associated with the elimination of a leaving group X:

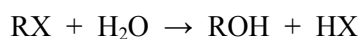

In water, the reaction is catalysed mainly by  $\text{H}^+$  and  $\text{OH}^-$  ions.

Hydrolysis is a process step used, for example, in the production of silicones (see Section 6.3.2.7).

#### Environmental issues

Air: hydrolysis may generate off-gases (e.g. in the production of silicones, see Section 6.3.3.2).

Water: waste waters can be generated in the hydrolysis operations (e.g. in the production of silicones, see Section 6.3.3.3). Hydrolysis consumes water.

### 2.2.13 Extraction

#### Description

Extraction is the most important liquid-liquid separation process used in industrial chemistry. It is used mainly where other separation methods or direct distillation are ineffective or too expensive. Its typical uses include:

- separation of components with similar boiling points
- separation of high boilers from aqueous solutions
- separation of mixtures with high boiling points
- separation of temperature sensitive compounds
- separation of azeotropic mixtures (e.g. extraction of acetic acid from aqueous media)
- separation of pollutants for the minimisation of waste water streams.

In order to extract the desired substance(s) from the solution, an extraction solvent that is immiscible in the solution is added. During the contact – called extraction – between the feed stream and the solvent, the targeted substance(s) undergo transfer from the initial solution to the solvent. Generally, the desired substance is then separated from the solvent by distillation and the solvent is recycled. Sometimes, the selective action of the solvent is used in combination with distillation (extractive distillation or azeotropic distillation). Various types of mixer-settlers, centrifugal extractors and columns are used as extraction apparatus.

Extraction is used, for example, in the production of inorganic salts of nickel.

#### Environmental issues

Water: the extracting agent (raffinate) is generally recycled and only a small amount of liquid waste is generated. If water is used as the solvent, it can then be biologically treated once any highly concentrated waste components have been separated. Other extracting agents may require incineration.

## 2.3 Raw and auxiliary materials and finished products storage and handling

Emissions may arise from the storage of raw and auxiliary materials, finished products and wastes during routine operations, unplanned events or during accidents. The substances used in the production process may be stored as gases, liquids or solids and the storage may take various forms, for example small bags, sacks, drums, Intermediate Bulk Containers (IBC) or tanks. Solids may even be stored in bulk in storage areas where measures are taken in order to prevent diffuse dust emissions (e.g. in the production of silicones), the concretion of hygroscopic materials (e.g. iron sulphate, aluminium sulphate, chloride salts, cyanides) or to avoid unexpected chemical reactions due to exceeding the critical mass of a substance (e.g. ammonium nitrate, iron (II) oxide, activated carbon). Emissions may also occur while materials are being conveyed to and from storage vessels.

As part of the production process equipment, storage is subject to risks of over-pressurisation, leakage and equipment failure. HAZard and OPerability studies (HAZOP) are carried out on storage and handling facilities to provide a structured assessment of failure events and their mitigation. Risk analyses using the HAZOP methodology are extensively used in the production of SIC explosives. The detailed design of storage depends on the nature of the substance, the quantity stored and the proximity of environmental receptors. Large, integrated chemical production sites may involve lower risks of spillage because they obviate the need for the loading of transfer vessels (rail or road tankers, or boats), and their transportation and unloading at a destination. However, these sites often necessitate chemicals being pumped through long pipe networks and this introduces risks of failure on remote pipe-runs.

With regard to storage, many of the techniques for preventing emissions are used in common ways across industry and in particular the SIC sector. Rather than being described repeatedly in many different BREFs, they are mostly covered in two BREFs; the horizontal BREF on 'Emissions from Storage' [8, European IPPC Bureau, 2003] and the horizontal BREF on 'Waste Water and Waste Gas Treatment/Management Systems in the Chemical Sector' [21, European IPPC Bureau, 2003], both of which should be read in conjunction with this document.

## 2.4 Process-integrated measures for emissions prevention and reduction

[21, European IPPC Bureau, 2003]

Advanced environmental protection is shifting more and more from end-of-pipe methods to process-integrated – or production-integrated – measures. Process-integrated measures are a source of significant environmental improvement in both new and existing plants. They are intended to reduce – or even avoid – the generation of residues (understood broadly to include waste gas, waste water, wastes, heat, vibration and noise) by intervention at source before they become a discharge (into the air, water or soil). Often these 'process improvements' help to decrease costs for additional treatment measures, as well as increase economic efficiency by increasing production yield and/or decreasing input of raw material. Disposal costs and the limitations of end-of-pipe treatments can influence this shift towards process-integrated measures. Although the prevention of emissions, and thus the implementation of process-integrated measures, is becoming increasingly significant, end-of-pipe techniques will remain essential contributors to the control of emissions into the environment, mainly when process-integrated measures are not feasible for the existing production.



Proper process-integrated environmental protection uses all possible physical, chemical, biological and engineering techniques for the prevention, reduction and recycling of residues. Examples are:

- new synthesis pathways
- use of purer or even different raw materials and process agents
- use of purer or different fuels
- optimisation of process steps
- improved plant technology, process control and reaction sequences
- technical adaptations to the process
- improved use of catalysts and/or solvents
- recycling of auxiliaries (e.g. washing/rinsing water, inert gases, solvents, catalysts)
- recycling of residues immediately during the process
- use of residues as the raw material for other productions (product integration within and/or outside the installation)
- use of residues for energy generation.

Obviously, the development of completely new pathways for syntheses in existing SIC plants will – mostly for economic reasons – remain an exception, and will be restricted to products of high economic value. In practice, production-integrated environmental protection will progress continuously as the sum of many individual – and maybe small – improvements over time.

## 2.5 Emissions abatement systems

### 2.5.1 General overview

[21, European IPPC Bureau, 2003] [18, European IPPC Bureau, 2004]

Emissions abatement systems (end-of-pipe systems) are those systems that enable the collection, re-use, treatment and disposal of unwanted liquids, gases and solids containing those pollutants that have not been addressed by process-integrated measures (see Section 2.4).

With regard to waste waters, abatement systems used in the SIC sector encompass pretreatment or final treatment of segregated waste water streams as well as the central treatment of collected waste waters before discharge into a receiving water. Pretreatment of segregated waste water streams may be necessary to protect the waste water treatment plant (located on site or off site).

With regard to waste gases, abatement systems used in the SIC sector are concerned, in general, with the reduction of:

- particulate matter (e.g. dust, heavy metals)
- vapours of volatile liquid substances
- gaseous air contaminants.

Waste gas treatment normally takes place directly at source. Only rarely can waste gas streams with different characteristics be treated simultaneously in one central treatment unit. One main reason is that treatment units are normally specifically designed for a particular waste gas composition. Another important reason is that special attention must be paid to the release of toxic and hazardous components and their impact on the surroundings as well as on the safety of the plant. In the SIC sector, given the toxicity and/or hazardous characteristics of many substances (e.g. cyanides, phosphorus compounds), safety is often a crucial issue.

Figure 2.2 provides an overview of the abatement systems at a typical SIC installation site and the usual pathways for waste, waste gas and waste water streams.

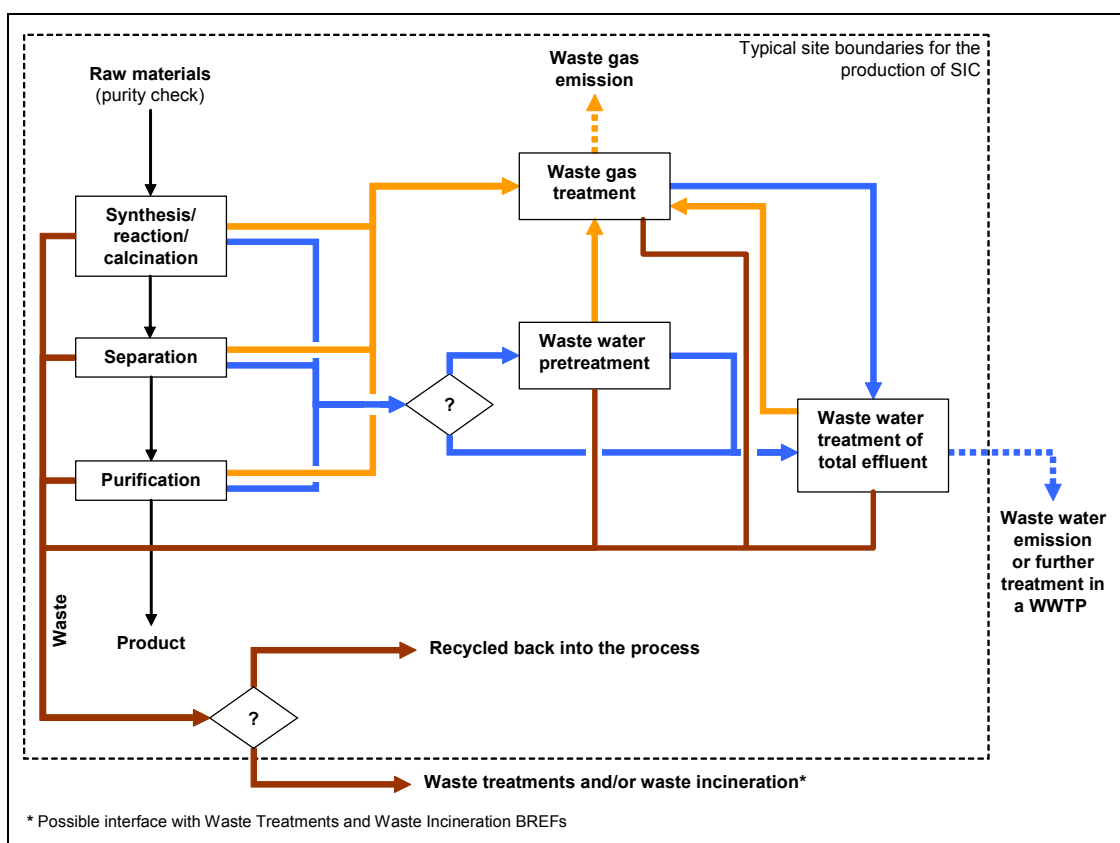

**Figure 2.2: Overview of the abatement systems used at a typical SIC installation**

Abatement systems which are usually located on the premises of the SIC installation and occasionally dedicated to particular processes are:

- waste gas treatments
- waste water pretreatments.

Abatement systems which are usually located on the premises of the SIC installation but are not dedicated to particular processes, but occasionally located off-site are:

- waste water treatment plants, occasionally municipal waste water treatment plants or plants operated by a municipality.

Those which are usually located off-site, but occasionally on the premises of the SIC installation are:

- waste incineration plants.

## 2.5.2 Waste gas treatment techniques

The choice of a waste gas abatement technique or of a particular sequence of techniques depends on the pollutants present in the waste gas stream. Events of planned or emergency shut downs require back-up systems.

A selection of techniques reported to be used or considered likely to be commonly used in the SIC sector is given in Table 2.2, which is based on Table 1.3 of the CWW BREF [21, European IPPC Bureau, 2003].

Technique	Organic gaseous or volatile components					Inorganic gaseous or volatile components		Odour	
	Organic particulates			Inorganic particulates		Wet matter			
	Dry matter								
	<b>Dust treatment</b>								
	Separator (pre)	X	X	X	X				
	Cyclone (pre)	X	X	X	X				
Wet dust scrubber (FT)	X	X	X	X	(X)	(X)			
Electrostatic precipitator (FT)	X	X	X	X					
Fabric filter (incl. ceramic filter) (FT)	X		X	X					
Two-stage dust filter (pol)	X		X	X					
Absolute (HEPA) filter (pol)	X		X	X					
HEAF (pol)		X							
Mist filter (pre, pol)		X			(X)				
<b>Gas treatment</b>									
Condenser (pre)					(X)	X			
Cryocondensation (pre, FT)					(X)	X	(X)		
Wet gas scrubber (water) (FT)	(X)	(X)	(X)	(X)	X	X	X		
Wet gas scrubber (alkaline) (FT)	(X)	(X)	(X)	(X)	X	X	X		
Wet gas scrubber (alkaline-oxidation) (FT)	(X)	(X)	(X)	(X)			X		
Wet gas scrubber (acidic) (FT)	(X)	(X)	(X)	(X)	X	X	X		
Thermal oxidation (FT)				X		X	X		
Catalytic oxidation (FT)						X	X		
Flaring* (FT)						X	X		
<b>Combustion gas treatment</b>									
Dry alkali injection (FT)					X				
Semi-dry alkali injection (FT)					X				
Wet lime injection (FT)					X				
SNCR (FT)					X				
SCR (FT)					X	(X)			
X: primary application (X): secondary application (pre): mainly as pretreatment facility (FT): treatment technique used as final treatment technique (pol): mainly as polishing technique after standard technique * Flaring may only be used in emergency situations									

**Table 2.2: Selection of techniques for waste gas emission reduction in relation to the pollutant to be removed**

It should be noted that the following techniques identified in the CWW BREF [21, European IPPC Bureau, 2003] have not been reported to be used in the SIC sector in the course of the elaboration of this document (the reason is that they mainly target organic pollutants in the waste gas):

- catalytic filtration
- membrane separation
- adsorption
- biofiltration
- bioscrubbing
- biotrickling.

### 2.5.3 Waste water treatment techniques

The water effluents of a SIC installation are usually treated in a central Waste Water Treatment Plant (WWTP) either dedicated to the SIC production or to several other productions when the SIC installation is located on a larger chemical complex.

The different waste water end-of-pipe treatment techniques reported to be used or considered likely to be commonly used in the SIC sector and their applicability to control the main contaminants in the SIC sector are shown in Table 2.3, which is based on Table 1.1 of the CWW BREF [21, European IPPC Bureau, 2003].

Technique	TSS	BOD COD TOC	Refrac- tory COD	AOX EOX	N- total	NH <sub>4</sub> -N (NH <sub>3</sub> )	PO <sub>4</sub> -P	Heavy metals	Phe- nols	Oil
<b>Separation or clarification techniques</b>										
Sedimentation* <sup>1</sup>	X	(X) <sup>a</sup>						(X) <sup>j</sup>		
Air flotation	X	X <sup>b</sup>						(X) <sup>j</sup>		X
Filtration	X	(X) <sup>a</sup>						(X) <sup>j</sup>		
Microfiltration (MF) /Ultrafiltration (UF)	(X) <sup>c</sup>	(X) <sup>a</sup>								
<b>Physico-chemical treatment techniques</b>										
Precipitation*							X	X		
Crystallisation							X	X		
Chemical oxidation		X	X	X						
Chemical reduction								X		
Nanofiltration (NF)/Reverse osmosis (RO)		X	X	X				X		
Adsorption		X	X	X				X		
Ion exchange		(X) <sup>d</sup>						X		
Evaporation		(X) <sup>e</sup>						X		
Stripping		(X) <sup>f</sup>		X		X				
Incineration		X	X	(X) <sup>g</sup>		X			X	X
<b>Biological treatment techniques</b>										
Anaerobic biological digestion		X		(X) <sup>h</sup>	(X) <sup>h</sup>			X <sup>1</sup>		
Aerobic biological digestion		X		(X) <sup>h</sup>			X		X	
Nitrification/ denitrification					X	X				
X: primary application (X): secondary application <sup>1</sup> Including coagulation/flocculation * Precipitation and sedimentation techniques are often used in combination (see Section 4.4.1) <sup>a</sup> Only solid <sup>b</sup> Undissolved organic content <sup>c</sup> Finely dispersed and low concentration <sup>d</sup> Ionic organic species <sup>e</sup> Non-volatile organic content <sup>f</sup> Volatile organic content <sup>g</sup> Special incinerator equipment required <sup>h</sup> Only biodegradable parts <sup>j</sup> Undissolved heavy metal compounds <sup>1</sup> In combination with sulphate precipitated as sulphides										

**Table 2.3: Major waste water contaminants and their respective treatment techniques**

It should be noted that the following techniques identified in the CWW BREF [21, European IPPC Bureau, 2003] have not been reported to be used in the SIC sector in the course of the elaboration of this document (the reason is that they mainly target organic pollutants of the waste water which are not generally pollutants of concern in the production of SIC):

- oil-water separation
- wet air oxidation
- Super Critical Water Oxidation (SCWO)
- chemical hydrolysis
- extraction
- distillation/rectification.

## 2.6 Process equipment and infrastructure

Every SIC production site has a comprehensive infrastructure that interconnects the production units (see Figure 2.1). In particular, the infrastructure provides the essential hardware and services (including utilities and monitoring practices) to ensure that the production process operates effectively, safely and without detriment to the environment. The following sections provide brief descriptions of the process equipment and the supporting infrastructure of a SIC installation as well as the associated environmental issues.

Common pollution abatement equipment that can be used in SIC installations is described in Chapter 4.

### 2.6.1 Reactors

Reactors are usually the core operation of a process because they are used for converting the raw materials into crude products. There is a wide range of reactor types, and designs may be very specific to a process, but reactors can be broadly classified according to:

- mode of operation (continuous or batch): SIC processes use continuous modes of operation (e.g. phosphorus compounds, silicones) as well as batch operations (e.g. inorganic explosives)
- reaction phase: production of SIC substances may be carried out in reactors as heterogeneously catalysed reactions where gaseous reagents make contact with a solid catalyst to form gaseous products. This has the advantage of avoiding a mixture of product with catalyst or solvent, but has the disadvantages that feed is often applied at high dilution and low conversions are achieved. Gas-liquid reactions are also important, and may be undertaken in a variety of reactors such as continuously stirred tanks, plug flows or bubble column reactors
- reactor geometry: the flow pattern and manner of contacting the phases. Some typical reactor configurations are:
  - fixed bed tubular
  - fixed bed multi-tubes
  - fluidised-bed.

Reactors are required to withstand a range of corrosive conditions, temperature and pressure and are thus usually made in the SIC sector of steel, glass-lined carbon steel, or coated (e.g. resins, enamel, PTFE) material. The actual design takes into account the following factors:

- chemistry (the reaction kinetics determine the residence time to achieve the necessary degree of conversion of raw materials into the desired product)
- mass transfer (the diffusion rate of reacting species)
- heat transfer (the removal or addition of reaction heat)
- health and safety of the workers and protection of the environment (the prevention of releases by reaction control).

Other characteristics of reactors are:

- pressure vessel with jacket, with half-coils outside or inside
- sized from a few litres (e.g. for inorganic explosives) to 60 m<sup>3</sup>
- equipped with one or more stirrers ('impellers')
- jackets are often fitted around the vessel to provide heat transfer
- wall baffles are installed inside to prevent the gross rotation ('swirl') of the contents with the stirrer.

Under normal operating conditions there are five major sources of waste production in reactors:

- a primary reaction between feedstocks (raw materials)
- a secondary reaction subsequent to the primary reaction
- impurities contained in the raw materials (e.g. benzene in HCN raw material for the production of cyanides)
- catalyst degradation or loss during cleaning of the reactor
- the inability to recycle unreacted feedstock back into the reactor.

Effluents seldom originate directly from reactors and, in most cases, the main pollution load results from product separation and purification.

Atmospheric emissions to the air from reactors may originate from:

- direct reactor process vents from liquid phase reactors
- vents from recovery devices serving streams on liquid phase reactors (enables the recovery of raw materials, products and by-products)
- process vents from gas phase reactors (after either the primary or secondary product recovery device)
- exhaust gases from combustion devices applied to any of the above streams
- fugitive losses from agitator seals, circulating pump seals, safety valves, flanges, valve stem packing, etc.

Reactors are served by inlets (to allow the addition of chemical reagents and inert reaction atmospheres) and outlets (for the removal of products, wastes and emergency venting). There will also be access points for measuring reaction conditions, for maintenance activities and for an agitator to provide full mixing of the reagents. These connections represent potential points of loss and hence the number of these should be minimised.

It is also usual for reactors to be served by some form of internal or external heat exchanger to provide for temperature control by either heating and/or cooling. In order to dampen temperature fluctuations and minimise energy losses, a reactor may be insulated.

The emptying and cleaning of reactors are potential sources of losses, and these can be minimised by:

- reducing internal obstructions
- installing the drain at the lowest point
- designing inlets that slope back into the reactor.

This is complemented by operational practices such as keeping the system warm to assist draining, the use of steam cleaning and the planning of production campaigns (when used) to minimise product changes.

## 2.6.2 Pumps, compressors and fans

Pumps, compressors and fans (blowers) are widely used in SIC installations to increase pressure and hence induce the movement of liquids or gases between equipment. There is a wide choice of equipment, much of it developed for particular applications, but there is a general distinction between centrifugal, rotating and reciprocal types.

Pumps require seals (often a packed gland) to prevent liquid loss from the interface between the moving shaft and stationary casing, but there is a need for a low level of leakage over the sealing surfaces to provide lubrication. Mechanical seals provide lower leakage than packed glands on rotating shafts, as long as the seal is correctly aligned and not exposed to vibration. Double mechanical seals provide a further level of leak prevention and rely on the pressurisation of fluid in the void between the two seals. Still higher levels of protection are provided by pumps that dispense with seals (e.g. magnetic drive centrifugal, canned centrifugal, diaphragm and peristaltic), although such pumps may be less energy efficient.

Compressors have many similar features to pumps, although there are more complicated arrangements for the lubrication and cooling of the interface between the stationary and moving parts of the seal. The common types of compressor seal can be categorised as:

- labyrinth
- restrictive ring
- mechanical
- liquid film
- magnetic ring.

The shaft sealing system usually has a gas bleed and this may require abatement.

## 2.6.3 Pipes

Conduits for the transfer of gases, liquids and solids are an integral part of all production processes. Pipe design is dependent on such factors as operating pressure, temperature and corrosivity of substances, so it is very specific to each installation. Well designed pipes rarely suffer from catastrophic failure and most losses are associated with pipe connections. Pipe connections either have the purpose of joining pipes (i.e. two pieces of straight pipe, changing pipe direction, changing pipe diameter, joining two streams) or linking ancillary process equipment (e.g. pumps, compressors, tanks, valves). These connections may be made by a variety of methods such as flanges, welding, threads. Special considerations are introduced where the pipes are lined. There is a general intention to minimise the length of pipe runs and to minimise the number of connections. Inspection and maintenance regimes are important for minimising fugitive emissions from pipes, especially where pipes are installed in infrequently visited parts of an installation.

### 2.6.4 Valves

Valves are widely used in installations for controlling or preventing the flow of gases and liquids. The choice and design of valves is very specific to the application. Valve internal parts are usually actuated externally and this necessitates an operating stem. The loss of process fluid from valves is usually prevented by the use of a packed gland seal, in a similar manner to pumps, but under the influence of heat, pressure, vibration and corrosion, the packing can lose its integrity and allow leaks.

These losses can be reduced by the use of bellows or diaphragms to isolate valve actuation from the process fluids. However, bellow valves are significantly more expensive than gate valves and their size may pose piping layout problems. Likewise, the use of diaphragm valves may be restricted by the pressures, temperatures and corrosive environments typically encountered in SIC installations.

The use of packed valves incorporating live loading spring assemblies mounted on the gland bolts compensates normal packing relaxation or the effects of thermal cycling and vibration. 'Valve live loading' offers considerable improvements in long term 'sealability' on rising stem gate valves, globe valves and regulating control valves. In the US, 'valve live loading' is deemed as MACT (Maximum Achievable Control Technology), 'equivalent to' a bellow valve. On frequently operated rising stem valves (most problematic), 'live loading' offers a considerable improvement in long term emissions performance (<500 ppm for 3 to 5 years) [30, European IPPC Bureau, 2003].

Valves that fail to perform as designed can have severe environmental implications – either for fugitive emissions or catastrophic failure. The risk of mechanical failure can be minimised by an appropriate regime of inspection and maintenance. However, valve failure is more frequently due to incorrect operation and this underlines the need for effective operating procedures.

### 2.6.5 Utility fluids

A variety of gases (among which are inert gases) are used in SIC installations to facilitate the operation of equipment or to carry out specific activities. SIC installations may have distribution systems for such gases as nitrogen, carbon dioxide and compressed air. These gases are usually inert and relatively benign in their own right, but may become contaminated with products or wastes in performing their duties and may, therefore, require treatment.

Compressed air, carbon dioxide and nitrogen have important uses for purging vessels and equipment of toxic or flammable atmospheres. Vessels are typically purged with air prior to opening, and with nitrogen or carbon dioxide prior to start up. Air purging of vessels is not applicable to all processes where flammable vapours can be present and steam purging or nitrogen blowing is used instead. The desire, on environmental grounds, to minimise the quantity of purge gas has to be balanced against the overriding health and safety requirements. However, there may be scope to reduce purge volumes by questioning the need for vessel opening and by continuously analysing an indicator parameter (such as oxygen) to identify when purging is complete. The contamination of purges can also be reduced by ensuring that the installation is fully drained prior to the introduction of purge flows.

Compressed dry air is used for cleaning purposes, actuating control valves, actuating on/off valves and for operating instruments, but is less and less used for actuating the pneumatic controllers used in plant control. Installations also typically have a variety of reticulation systems for different qualities of water (e.g. drinking water, demineralised for boiler feed).

As inert gases and carbon dioxide can pose serious health risks to the workers under certain conditions, adherence to very strict rules when using these gases is required [33, European Industrial Gases Association, 1999].



## 2.6.6 Cooling and refrigeration systems

As a general rule, cooling systems are only adopted when appearances of waste heat have been minimised and all economically sound opportunities for heat re-use have been exhausted. By applying such heat integration, significant energy can be saved and the associated emissions reduced. The removal of heat from exothermic processes is very important for process control and safety reasons, and cooling may also be required to create the right conditions for certain process steps (e.g. liquefaction of lower boiling compounds). Nearly all SIC installations have an extensive cooling system; most commonly using water as the cooling medium, but with increasing use of air-cooling. For cooling below approximately 20 °C, other cooling media are normally required (e.g. ammonia, hydrocarbons, carbon dioxide).

Cooling systems typically involve some form of heat exchanger to remove heat from the process, a heat transfer medium and a mechanism for dissipating heat into the environment. A wide variety of cooling technologies are available and as these technologies are used in common ways across industry, they are covered in detail in the dedicated horizontal BREF on Industrial Cooling Systems [31, European IPPC Bureau, 2000]. The application of cooling systems is highly dependent on site-specific conditions and each case needs to be evaluated individually using the principles in the horizontal CV BREF [36, European IPPC Bureau, 2003] in order to establish the cooling requirements.

The main considerations are:

- potential losses of process materials which depend heavily on the effectiveness of the cooling systems used for condensation
- resource consumption (e.g. water, air, energy, chemical substances)
- emissions to water (chemicals and heat) and air
- noise emissions
- plumes
- waste generation
- risk aspects
- pollution arising from specific events (start ups/shut downs) or incidents
- effects of process and equipment design, and of material and maintenance
- decommissioning of installations.

In general, evaporative cooling towers for water are designed to ensure that condensed plumes do not reach ground level as this can cause nuisance (loss of light, reduced visibility, icy roads) and contamination (with biocides or micro-organisms). Cooling circuits are also monitored for process fluid contamination using an appropriate indicator parameter (e.g. conductivity) and temperature alarms are fitted to warn of overheating.

Cooling can be carried out directly or indirectly. Direct cooling is carried out by injecting water, usually to cool down vapour phases. Indirect cooling is provided by heat exchangers (condensers), where the cooling medium (e.g. water, brines) is pumped in a separate circle.

Refrigeration is provided where processes require temperatures below those that can be obtained with cooling water – usually by a central site facility. Chlorofluorocarbons (CFCs) or intermediate substances such as hydrochlorofluorocarbons (HCFCs) are not generally used in new refrigeration systems because of their detrimental effect on the ozone layer. The source of cooling is distributed around a site using either chilled water (for temperatures down to about 10 °C) or salt brines (down to -30 °C). Measures are taken to minimise the loss of refrigerants from pumps, pipe joints, etc. Local detection systems such as Leak Detection And Repair (LDAR) systems may be used for detecting fugitive losses.

The environmental aspects of cooling systems vary with the applied cooling configuration, but the focus is predominantly on increasing the overall energy efficiency and reducing emissions to the aquatic environment. The consumption and emission levels are very site-specific and, where it is possible to quantify them, they show large variations. In the philosophy of an integrated BAT approach, cross-media effects must be taken into account in the assessment of each environmental aspect and the associated reduction measures [21, European IPPC Bureau, 2003].

### 2.6.7 Cleaning systems

Cleaning of the process equipment at the SIC installation plant is necessary because, with time, the production operation causes residues to build up in the equipment. The residues are, for example, unreacted raw materials, spent catalysts, or by-products. Cleaning is necessary to ensure a high product quality, process efficiency, and safety of the workers.

The cleaning of the process equipment is generally carried out in SIC installations using water, air and, in some cases, the following substances:

- sodium hydroxide
- hydrochloric acid
- acetone
- specific solvents
- steam.

The choice of the cleaning media depends on the equipment to be cleaned and the substances that need to be removed by the cleaning operation. The cleaning process is finished with water to rinse the equipment and the waste water is treated.

The cleaning process can be carried out in different ways:

- **with hoses:** cleaning is carried out with pressurised water from a hose to reduce water consumption, and the waste waters are carried towards a WWTP. If solvents are used instead of water, they are collected and recovered where possible
- **Cleaning-In-Place (CIP) systems:** CIP systems have been developed to limit emissions, improve efficiency of the cleaning process and for the health and safety of the workers. Cleaning-In-Place systems allow equipment to be cleaned directly inside with water scatterers under pressure and allow washing liquids to be recovered. CIP systems also enable the operator to carry out the cleaning process without the need to take equipment apart or for workers to enter the vessels, which limits workers exposure to potentially harmful substances (see Section 6.5.4.3 and Section 4.5.1).

### 2.6.8 Vacuum systems

There may be demands for reduced pressure on a SIC installation. The vacuum duty depends on the quantity of gas being handled and the degree of cooling/condensation in the system. Vacuum can be provided in several ways that have been summarised as follows:

- **steam jet ejectors:** these are simple, reliable and widely used, although they can be noisy. They create a low concentration effluent, but this can be minimised by using surface (rather than direct) condensers on the steam jet
- **liquid ring pumps:** the maximum attainable vacuum is limited by the vapour pressure of the sealing fluid. Some contaminants in the gas stream are taken up by the sealing liquid, and sealing liquid purge forms a concentrated effluent that may be recovered or treated. The process fluid can be used for sealing and this reduces effluent formation. This type of pump can be noisy
- **dry vacuum pumps:** these pumps do not produce an effluent as the seal is achieved by high rotation speeds of the rotary pump and close tolerances. The presence of condensable liquids or solids can cause excessive maintenance or breakdown. Dry vacuum pumps cannot be used where the process fluid is potentially explosive in normal or abnormal conditions.

The ingress of air through seals is a major factor in the efficiency of vacuum systems. Air ingress can be reduced by careful design, correct equipment choice and frequent maintenance. Instrumentation may be used to detect excessive flows.

### 2.6.9 Storage systems

SIC installations use storage systems to store liquids, liquefied gases and solids that are utilised or produced during plant operations (e.g. raw and auxiliary materials, finished products and by-products, wastes).

The following systems are used at SIC installations to store liquids and liquefied gases:

- open top tanks (atmospheric)
- (vertical) fixed roof tanks (atmospheric)
- aboveground horizontal storage tanks (atmospheric or pressurised)
- underground horizontal storage tanks (atmospheric or pressurised)
- vertical storage tanks (pressurised)
- spheres (pressurised)
- containers (e.g. glass containers, drums, plastic composite containers, composite containers, Intermediate Bulk Containers – IBC).

The following systems are used at SIC installations to store solids:

- heaps (outdoors or in buildings)
- sacks and bulk bags
- silos and bunkers
- packaging for dangerous solids (e.g. packaging made of primary and secondary receptacles).

Emissions to the environment could occur from the operation of storage systems, whether from normal operating conditions (including transferring substances in and out of storage and cleaning) or from incidents and accidents.

Such emissions can be:

- emissions to air
- emissions (discharges) to water (direct/indirect)
- noise emissions
- waste emissions.

Further information on the storage systems mentioned in this section and the possible emissions associated with their operation can be found in the ESB BREF [8, European IPPC Bureau, 2003].

### 2.6.10 Transfer and handling systems

SIC installations use different systems to transfer gas, liquid or solid materials from one process step to another or to and from storage.

The following systems are used at SIC installations to transfer and handle gases and liquids:

- aboveground closed piping transfer systems
- aboveground open piping transfer systems
- underground piping transfer systems
- flexible hoses and rigid pipelines for unloading.

The following systems are used at SIC installations to transfer and handle solids:

- dump trucks (e.g. in the production of silicones, see Section 6.3.2.2)
- suction air conveyors
- pressure air conveyors
- bucket elevators (e.g. in the production of silicones, see Section 6.3.2.2).

Further information on the transfer and handling systems mentioned in this section and the possible emissions associated with their operation can be found in the ESB BREF [8, European IPPC Bureau, 2003].

### 2.6.11 Monitoring practices

There is generally no particular aspect in the SIC sector justifying monitoring approaches or practices which have not been included in the MON BREF [36, European IPPC Bureau, 2003].

As a special case, monitoring of explosive traces in waste water is carried out daily in most SIC installations producing explosives.

For health and safety reasons, monitoring devices can be installed in the work areas of SIC installations for the detection of hazardous substances (e.g. NH<sub>3</sub> and HCN in the production of cyanides).

## 2.7 Energy supply

Many of the reaction, separation and purification steps in SIC processes have a (sometimes significant) requirement for energy. The energy source depends on the process requirements and the local availability. Many operators subcontract the energy supply to third parties or use the central facilities that exist on many industrial sites. The main sources of energy are direct-fired process furnaces, steam boilers, power generation in turbines and heat exchange (against a hotter product or raw material). More information on combustion units such as boilers and gas turbines may be found in the LCP BREF [32, European IPPC Bureau, 2004].

Process furnaces are the primary source of heat in many endothermic chemical processes and are typically fired on gas or liquid fuels. Process furnaces are often chemical reactors and are energy consumers. Like heat exchangers they are considered as process equipment.

Steam is normally generated in steam boilers or in Combined Heat and Power (CHP) units. Energy from boilers is distributed around an installation using a heat transfer medium (usually steam, but possibly water or oil). A large industrial complex usually has steam available at several energy levels (high, medium and/or low pressure). Heat is input to the process either directly (e.g. by steam injection) or indirectly by some form of heat exchanger equipment (typically shell and tube type). The condensate from steam use will have its own collection system for return to the boiler.

Electrical power is needed for equipment such as pumps, mixers, compressors, and lighting. Power can be generated on-site or purchased but there is a trend in the chemical industry to combine power and steam generation in CHP units. CHP units fulfill the need for both steam and electricity and have a very high overall energy efficiency. They also reduce the dependence on external power supplies, and can generate excess power for the grid. CHP is most successful where the heat to power ratio is at least 1:1 and power is needed for at least 6000 hours per year. However, the dependence on external power supplies increases when CHP units are built and operated by a third party.

## 2.8 Management systems

Although management systems are fundamental components of the SIC production process (and are shown as such in Figure 2.1), they are described in Section 4.7.6 because of their crucial importance as a pollution prevention and control technique.



### 3 COMMON CONSUMPTION AND EMISSION LEVELS

Consumption and emission levels are very specific to each SIC production process. It is difficult to precisely define and quantify them unless the specific process under scrutiny has undergone a detailed information exchange.

The character and scale of emissions are highly variable from one SIC process to another due to differences in, e.g:

- the composition of the raw material, in particular their content of impurities
- the product range
- the nature of intermediates
- the use of auxiliary materials
- the process routes and conditions
- the extent of in-process emission prevention techniques
- the type of waste streams end-of-pipe treatments.

In addition, as for any chemical installation, emissions from a given SIC installation vary over time depending on the operating scenario:

- routine operation
- non-routine operation (e.g. start up, shut down, maintenance, incident)
- emergencies (e.g. fires, explosions, accidents)
- decommissioning.

All this makes it difficult to provide generic consumption and emission levels applicable to the whole SIC sector. However, it is apparent from the information contained in Chapter 6 that SIC installations generally resort to end-of-pipe treatments (e.g. fabric filters, scrubbers) for emission abatement, in particular when hazardous substances are involved. It is considered that the emission levels achieved with the abatement systems used in the SIC sector are generally in line with the emission levels indicated in the CWW BREF [21, European IPPC Bureau, 2003].

As SIC processes utilise many common process steps and equipment (see Chapter 2), it is possible to consider (in a generic manner) where emissions may arise (i.e. emission sources) and what type of pollutant those emissions might contain. The following lists of emission sources are neither exhaustive, nor will all mentioned emission sources be present in every SIC process, but the following sections provide a checklist of possible emission sources and components against which assessments on any SIC production process can be made.

#### 3.1 Air emissions

As indicated in Chapter 2, any SIC production process can be seen in a generic way as a sequence of five general steps and three complementary activities (see Figure 2.1). The component parts of that generic process provide a useful structure for identifying the potential sources and types of air emissions, and some of these are listed below.

Table 3.1 presents the main pollutants that could be emitted to the air during the production of some SIC substances (some of the pollutants marked in the table for a subgroup of substances produced are not always present in every individual process – e.g. organic compounds and VOCs are not present in all CIC pigments manufacturing processes).

SIC substances produced	Dust	SO <sub>2</sub>	NO <sub>x</sub>	CO <sub>2</sub>	Fluorides	Organic compounds	HCl	HCN	NH <sub>3</sub>	VOCs	P oxides	Metal compounds
Explosives	X					X				X		
Pigments	X	X	X	X	X	X			X	X		X
Cyanides			X					X	X	X		
Silicones	X		X				X			X		
Phosphorus compounds							X				X	
Nickel salts	X		X <sup>a</sup>									X

Only direct emissions from normal operating conditions are indicated.  
Some of the pollutants are not systematically present for the given family of SIC substances.  
<sup>a</sup> In the production of nickel dinitrate only

**Table 3.1: Main pollutants that could be emitted to the air during the production of some SIC substances**

### Raw and auxiliary materials supply, storage, handling and preparation

Possible sources of emissions	Possible pollutants emitted
Vents on distillation columns and stripping columns for removal of impurities in raw materials	
Vents on premixing vessels (e.g. dust, heavy metals)	
Loading/unloading of containers and vessels (tankers for road, rail and ship)	HNO <sub>3</sub> , H <sub>2</sub> SO <sub>4</sub>
Blanketing of storage tanks	
Losses from conveyors	Particulates
Evaporative losses from spills	VOCs
Diffuse emissions during handling with chargers	Particulates
Diffuse emissions from stockpiles	Particulates

### Synthesis/reaction/calcination

Possible sources of emissions	Possible pollutants emitted
Discrete vents serving reaction equipment (e.g. purges, inert vents from condensers, let-down vessels, process scrubbers)	
Vents associated with catalyst preparation and catalyst regeneration	VOCs, CO <sub>x</sub> , NO <sub>x</sub> , SO <sub>x</sub>
Vents on premixing vessels (e.g. dust, heavy metals)	
Relief devices to maintain safe operation (e.g. pressure relief valves, bursting discs)	

### Product separation and purification

Possible sources of emissions	Possible pollutants emitted
Vents serving separation equipment (e.g. distillation columns, stripping columns, crystallisers, condensers)	
Drying and handling of solids	Particulates
Regeneration of purification beds	CO <sub>x</sub> , VOCs



## Product handling and storage

Detailed information on sources of emissions may be found in the ESB BREF [8, European IPPC Bureau, 2003], but in general terms emissions may arise from:

Possible sources of emissions	Possible pollutants emitted
Loading/unloading of containers and vessels (tankers for road, rail and ship)	
Blanketing of storage tanks	VOCs
Losses from conveyors	Particulates
Evaporative losses from spills	VOCs

## Emissions abatement

Possible sources of emissions	Possible pollutants emitted
Waste gas combustion units (e.g. thermal post-combustion units, incinerators)	Secondary pollutants that did not exist in the original waste stream (e.g. dioxins, particulates), as well as combustion gases
Stripping of waste water (with air or steam)	Transfer of dissolved organics into the gaseous phase
Drains, balancing tanks from waste water collection systems	VOCs
Storage and treatment of solid wastes	Particulates

## Infrastructure

Possible sources of emissions	Possible pollutants emitted
Fugitive losses from equipment (e.g. compressors, pumps, valves)	
Cooling water contaminated with process streams (e.g. from equipment leakage) passing through cooling towers	
Workspace ventilation is primarily a health and safety issue. Although the pollutant concentrations are very low in ventilation air, there may be significant mass releases to the air because of the high air volumes involved	VOCs
Analysers and sampling ports	
Equipment evacuation and cleaning in preparation for access (e.g. maintenance)	VOCs

## Energy

Possible sources of emissions	Possible pollutants emitted
Combustion units for generating steam, heat and electricity (e.g. process heaters, furnaces)	Usual combustion gases (e.g. CO <sub>x</sub> , NO <sub>x</sub> , SO <sub>2</sub> , particulates) and other pollutants (e.g. acid gases, dioxins) if wastes are combusted

## Management systems

Inadequacies of management systems or failure of operators to adhere to procedures may be the source of process upsets or incidents with possible subsequent air emissions.

### 3.1.1 Diffuse emissions to air

Many SIC processes involve the handling of solid materials and diffuse releases of dust and small particulates from joints in conveyors systems, from stockpiles (e.g. elemental silicon dust in the production of silicones), from packaging, etc. are significant issues for many installations.

In other processes, where gases or liquids with moderately high vapour pressures are handled, there is always the potential for releases of acid gases, ammonia, VOCs or volatile inorganic compounds from flanges, pumps, agitators and valves with seals, storage tanks, tanker connections, sample points, etc. These fugitive releases can occur through relaxation or progressive wear and tear of sealing materials, through poor operation, maintenance or design, or through failure of equipment. Apart from releases of material through accidental mal-operation or equipment failure, fugitive losses from individual pieces of equipment are often small – but on a large-scale installation the aggregated effect can be very significant.

### 3.1.2 Point source emissions to air

As with diffuse emissions, many SIC production processes involving the handling of solid materials release certain quantities of dust, fume or wet particulates from process vents – and some of these contain toxic substances such as heavy metal compounds. Other SIC installations release significant quantities of acid gases, ammonia or volatile inorganic or organic compounds from process vents on vessels, storage containers and abatement system exhausts.

## 3.2 Water emissions

Again, the generic approach to understand a SIC production process (see Figure 2.1) provides a useful structure for identifying the sources of water emissions. For all sources, attention should not only be paid to effluent streams that enter surface waters (rivers, lakes, seas), but also to unwanted discharges to groundwater – either directly or indirectly (via the contamination of soil).

Table 3.2 presents the pollutants that could be carried by the waste water discharged to the receiving waters during the production of some SIC substances.

SIC substances produced	AOX	BOD	COD	TOC	TSS	Aniline	Nitrates	Phosphates	Sulphates	As	Ba	Bi	Cd	Co	Cr	Cu	Fe	Ni	Pb	Sb	V	Zn	Cl	CN	NaCl	NH <sub>4</sub>
Explosives			X		X		X	X											X							
Pigments		X	X	X	X	X	X	X	X	X	X	X	X	X	X	X	X	X	X	X	X	X	X	X	X	X
Cyanides			X	X																				X	X	
Silicones	X		X						X							X						X	X			
Phosphorus compounds								X															X		X	
Nickel salts										X						X		X	X			X				

Only direct emissions from normal operating conditions are indicated.  
Some of the pollutants are not systematically present for the given family of SIC substances (e.g. aniline is not present in the manufacturing of CIC pigments).

**Table 3.2: Pollutants that could be carried by the waste water discharged to the receiving waters in the production of some SIC substances**

The sources of water emissions may include (depending in particular on the process, raw and auxiliary materials, and operating conditions used):

### Raw and auxiliary materials supply, storage, handling and preparation

Possible sources of emissions	Possible pollutants emitted
Storage tank overflows	HNO <sub>3</sub> , H <sub>2</sub> SO <sub>4</sub>
Mixing vessels (e.g. overflows, wash-down)	Pb(NO <sub>3</sub> ) <sub>2</sub>
Spills during loading/unloading	HNO <sub>3</sub> , H <sub>2</sub> SO <sub>4</sub> , Pb(NO <sub>3</sub> ) <sub>2</sub>
Leakage from tanks and pipe systems	HNO <sub>3</sub> , H <sub>2</sub> SO <sub>4</sub> , Pb(NO <sub>3</sub> ) <sub>2</sub>

### Synthesis/reaction/calcination

Possible sources of emissions	Possible pollutants emitted
When water is added as a reactant solvent or carrier	
Where reaction water is formed in the process (e.g. from a condensation reaction)	Pb, NO <sub>3</sub> <sup>-</sup> , COD
When water is present in the raw material	
Process purges and bleeds (especially of 'mother liquors')	
Quenching of organic vapour streams	

### Product separation and purification

Possible sources of emissions	Possible pollutants emitted
Where water is used for product washing and picks up traces of products/wastes	VOC (COD)
Spent neutralising agents (acid or alkali)	
Regeneration of ion exchange resins	NaCl
Solvent recovery	

### Product handling and storage

Detailed information on sources of emissions may be found in the ESB BREF [8, European IPPC Bureau, 2003], but in general terms emissions may arise from:

Possible sources of emissions	Possible pollutants emitted
Storage tank overflows	
Spills during loading/unloading	
Leakage from tanks and pipe systems	
Spillage from drums and IBCs	

### Emissions abatement

Possible sources of emissions	Possible pollutants emitted
Effluents may utilise neutralising agents (acid or alkali)	NO <sub>3</sub> <sup>-</sup> , NO <sub>2</sub> <sup>-</sup> , Pb <sup>2+</sup>
Air abatement systems (e.g. spent scrubber liquor)	
Dewatering of sludges	
Water bleed from seals, drums and knock-out drums	

## Infrastructure

Possible sources of emissions	Possible pollutants emitted
Cleaning operations (washing of vessels, pipes and other equipment to facilitate access, e.g. for maintenance purposes)	VOC (COD), Pb <sup>2+</sup> , NO <sub>3</sub> <sup>-</sup>
Fire-fighting water	
Rainwater run-off from floors	
Diffuse sources (e.g. leaks, spills from process equipment)	VOC (COD), Pb <sup>2+</sup>
Oil from mechanical equipment (compressors, etc.)	Oil
Contamination of condensate from steam ejectors used to create vacuum	
Water gland seals on vacuum pumps	
Vapour condensates in pipe runs	
General site effluents from offices, canteens, laboratories and workshops	BOD <sub>5</sub>
Water curtains for containment of hydrocarbons and/or absorption of acid gases	

## Energy

Possible sources of emissions
Hydrocarbon contamination of water cooling systems (e.g. from equipment leakage)
Bleed on the boiler feed-water (containing corrosion inhibitors, biocides and scale)
Bleed on the water demineralisation plant
Cooling system blowdown
Steam condensate contaminated with raw material, product, or waste (e.g. from equipment leakage)

## Management systems

Water emissions may occur from process upsets or incidents that are attributable to the inadequacies of management systems or the failure of operators to adhere to procedures.

Many SIC installations have small and easily treatable aqueous waste streams, but a number of them have effluent streams containing more difficult pollutants such as heavy metal compounds or complexes. Where it is not practicable to prevent the generation of these difficult waste water streams in the first place, they need to be segregated and treated separately.

## 3.3 Wastes

The form of wastes resulting from SIC production may range from discrete solid items to highly fluid sludges with significant water content. The nature of wastes is very dependent on the process. Wastes may be hazardous due to the presence of toxic organic substances or heavy metals.

The component parts of the general SIC production process presented in Section 2.2 (Figure 2.1) provide a useful structure for identifying the potential sources of wastes, and some of these are listed below.

Figure 3.1 shows that the type and amount of wastes generated in a typical SIC installation heavily depend on the following elements:

- purity of raw and auxiliary materials
- process-integrated measures taken to reduce waste (e.g. re-use, recycling)
- integration of the SIC installation into a larger production site
- quality requirements on the product by customers.

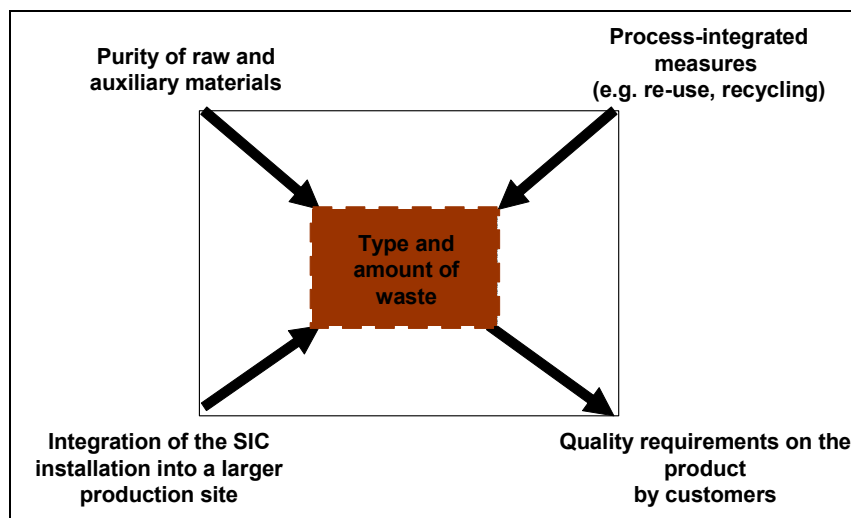

Figure 3.1: Factors on which the type and amount of waste in a typical SIC installation depend

The sources of wastes may include (depending in particular on the process, raw and auxiliary materials, and operating conditions used):

#### Raw and auxiliary materials supply, storage, handling and preparation

Possible sources of wastes	Possible pollutants emitted
Off-specification raw materials	
Waste packaging (e.g. spent drums, sacks)	Heavy metals, nitrates, VOCs
Product polymerisation in tanks	

#### Synthesis/reaction/calcination

Possible sources of wastes	Possible pollutants emitted
Spent catalyst and catalyst support. Catalysts may become spent because of chemical deactivation, physical degradation or fouling. The composition of catalysts varies greatly and is generally subject to a high level of confidentiality in the SIC sector. Many are based on expensive, exotic metals and this prompts recovery (either on or off site)	
Products of corrosion and erosion inside equipment (e.g. oxides of iron and other metals)	

### Product separation and purification

Possible sources of wastes	Possible pollutants emitted
Spent purification media. A variety of media are used to remove impurities such as water or unwanted by-products (e.g. activated carbon, molecular sieves, filter media, desiccants, ion exchange resins)	Activated carbon
Unwanted by-products	
Process residues (e.g. residues from distillation columns, tars and waxes, sludges in reactor vessels). These may have value as a by-product, feedstock for another process or as a fuel	
Spent reagents (e.g. solvents – these may be valuable to recover/re-use, or to use as a fuel to capture the calorific value)	
Off-specification products	Explosive waste

### Product handling and storage

Detailed information on sources of emissions may be found in the ESB BREF [8, European IPPC Bureau, 2003], but in general terms emissions may arise from:

Possible sources of wastes	Possible pollutants emitted
Waste packaging (e.g. spent drums, sacks)	Explosive waste
Product polymerisation in tanks	

### Emissions abatement

Possible sources of wastes	Possible pollutants emitted
Adsorbents used for spill clean-up	
Solids produced by the abatement of air pollutants (e.g. dust from electrostatic precipitators and bag filters)	
Solids produced by the abatement of water pollutants (e.g. catalyst solids settled from waste water, filter cake)	PbCO <sub>3</sub> , PbSO <sub>4</sub>

### Infrastructure

Possible sources of wastes	Possible pollutants emitted
Decommissioned plant equipment	
Construction materials (e.g. metal, concrete, insulation)	
General site wastes from offices, canteens and laboratories	Urban waste
Spent cleaning agents	Phosphoric acid
Spent oils (lubrication, hydraulic, etc.)	Used oil
Spent heat transfer fluids	

### Energy

Possible sources of wastes	Possible pollutants emitted
Ash/soot from furnaces, heaters and other combustion equipment	

### Management systems

Wastes may occur from process upsets or incidents that are attributable to the inadequacies of management systems or the failure of operators to adhere to procedures.

### 3.4 Odour and noise emissions

Odour and noise nuisances are not a general issue for the SIC sector, even if there can conceivably be local concerns in some SIC installations.

### 3.5 Energy consumption

Energy consumption in the SIC sector varies very much depending on the products manufactured and the processes used.

The SIC sector is not generally considered a large energy consumer compared to other chemical sectors. Only when calcination operations are used does energy become an important factor (e.g. in the production of some inorganic pigments).

A few examples of energy consumption and recovery are given in the various sections of Chapter 6.

Energy is used in the SIC sector in the form of electricity to power equipment (e.g. motors, pumps, valves, heaters, drivers and regulators) or fossil fuels (mainly natural gas) for heating purposes, to produce steam or hot water.

### 3.6 Water consumption

Water consumption in the SIC sector varies very much depending on the products manufactured and the processes used.

The SIC sector is not generally considered a large consumer of water compared to other chemical sectors. Only when washing operations are used does water become an important factor.

A few examples of water consumption and recovery are given in various sections of Chapter 6.

### 3.7 Factors influencing consumption and emission levels

Some of the consumption and emission levels contained in the illustrative sections of this document (Chapter 6) show considerable ranges and this makes the comparison of plant performance very difficult. Much of this variability is explained by the influence of a number of factors. An understanding of these factors is important for interpreting consumption and emission data from SIC processes and so brief explanations follow.

With regard to factors influencing waste emission levels, it is recommended to refer to Section 3.3 earlier in this chapter.

#### 3.7.1 Installation boundary definition and degree of integration

SIC installations can either be located on a larger industrial (typically chemical) complex, and thus benefit from the services of the complex such as utilities (e.g. steam, electricity, cooling water, industrial gases such as oxygen and nitrogen) and waste water/waste gas treatment, or be totally independent, standalone installations with dedicated utilities and abatement systems. Integration in a larger industrial complex also allows certain low value or potential waste streams to be recovered and utilised, or processed into saleable products thus eliminating the requirement for disposal.

### 3.7.2 Determination of consumption and emission levels

The absence of standardised methods for measuring and reporting consumptions and emissions makes direct comparison difficult.

With regard to consumptions (in particular for water and energy), companies operating several installations on the same site may not always measure consumption levels of the individual SIC installation and only hold information on the overall site consumptions.

Non-channelled (fugitive) emissions may be reported on the basis of direct measurements or estimates based on a technique that counts the number of emission point sources (flanges, valves, pumps, etc.) and applies standard emission factors relating to the contained fluid. The use of different measurement and reporting methodologies can lead to very different apparent emission levels for similar activities. However, the use of material balances often gives better results than measurements.

### 3.7.3 Definition of waste

The definition of what constitutes a 'waste' can have a significant effect on reported emissions and subsequent plant comparisons.

Solid waste generation and disposal is particularly complex as many operators are required to provide complete information, on e.g:

- hazardous wastes
- spent catalysts and desiccants
- scrap metals
- packaging materials
- office waste materials.

Elsewhere, reporting requirements are such that only some of these waste categories are measured and controlled. In some cases, spent catalysts go for off-site regeneration and/or precious metal recovery, rather than disposal, and are difficult to evaluate. Likewise, SIC installations located on highly integrated chemical production sites may appear to have less waste as they have more opportunities for upgrading waste streams into products.



## 4 COMMON TECHNIQUES TO CONSIDER IN THE DETERMINATION OF BAT

This chapter sets out techniques considered generally to have potential for achieving a high level of environmental protection in the sector within the scope of the document. Management systems, process-integrated techniques and end-of-pipe measures are included, but a certain amount of overlap exists between these three when seeking the optimum results.

Prevention, control, minimisation and recycling procedures are considered as well as the re-use of materials and energy.

Techniques may be presented singly or as combinations to achieve the objectives of IPPC. Annex IV to the Directive lists a number of general considerations to be taken into account when determining BAT; techniques within this chapter will address one or more of these considerations. As far as possible a standard structure is used to outline each technique, to enable comparison of techniques and an objective assessment against the definition of BAT given in the Directive.

The content of this chapter is not an exhaustive list of techniques and others may exist or be developed which may be equally valid within the framework of BAT.

Generally a standard structure is used to outline each technique, as shown in Table 4.1:

Type of information considered	Type of information included
Description	Technical description of the technique
Achieved environmental benefits	Main environmental impact(s) to be addressed by the technique (process or abatement), including emission values achieved and efficiency performance. Environmental benefits of the technique in comparison with others
Cross-media effects	Any side-effects and disadvantages caused by implementation of the technique. Details on the environmental problems of the technique in comparison with others
Operational data	Performance data on consumption and emissions/wastes (raw materials, water and energy). Any other useful information on how to operate, maintain and control the technique, including safety aspects, operability constraints of the technique, output quality, etc.
Applicability	Consideration of the factors involved in applying and retrofitting the technique (e.g. space availability, process specific)
Economics	Information on costs (investment and operation) and any possible savings (e.g. reduced raw material consumption, waste charges) also as related to the capacity of the technique
Driving force for implementation	Reasons, other than environmental ones, for implementation of the technique (e.g. legislation, improvement in production quality)
Example plants	Reference to plants where the technique is reported to be used
Reference literature	Literature for more detailed information on the technique

**Table 4.1: Information breakdown for each technique described in Chapter 4**

## 4.1 Structure of this chapter

There are many possible ways to structure this chapter, to organise the environmentally beneficial techniques that can be used in the SIC sector. The structure that is used below is one considered appropriate for SIC.

The techniques are presented in line with the generic approach to understand a SIC production process presented in Section 2.1; the techniques have thus been organised under the following main headings:

- raw and auxiliary materials supply, storage, handling and preparation
- synthesis/reaction/calcination
- product separation and purification
- product handling and storage
- emissions abatement (including waste treatment)
- infrastructure
- energy
- cross-boundary techniques.

The techniques presented are not grouped by environmental issues (e.g. emissions to air, water, soil, energy efficiency) because many techniques address, directly or indirectly, several of these issues. Neither are they grouped in process-integrated and end-of-pipe techniques, because there may not be a clear-cut boundary between the two categories. The reader can refer to Section 2.4 and Section 2.5 of this document in order to make their own judgement on whether a technique presented in this chapter pertains to one category or the other.

Techniques that could fit under several of the headings related to the generic approach are grouped under 'cross-boundary techniques'.

## 4.2 Raw and auxiliary materials and finished products supply, storage, handling and preparation

### 4.2.1 Recycling or re-use of used containers/drums

#### Description

Suppliers of chemicals and additives take back their empty containers/drums (made of e.g. plastic, wood, metal) for recycling or re-use. The largest size container possible is used, taking into account the material behaviour. Some hygroscopic solid materials may form concrete-like blocks in large containers, under self-pressure (e.g. NaCl, FeSO<sub>4</sub>, cyanides). Other materials (e.g. sodium azide, nitrates) may present some risk of explosion or unexpected chemical reaction (e.g. self ignition of coal in humid air).

#### Achieved environmental benefits

- reduction of waste.

#### Cross-media effects

If containers are returned without further cleaning, no cross-media effects apply.

### **Applicability**

The technique is only applicable for 'hard' packaging like drums and containers starting with a specific size (60 litres) and is generally not applicable for bags. Only some big bags may be cleaned and recycled under special circumstances.

There are generally restrictions for the recycling of containers/drums due to the nature of the product transported (e.g. if toxic/dangerous). Re-use of containers/drums for the same type of product is generally not seen as problematic. In some countries (e.g. Spain) any significant content of toxic/dangerous (raw and auxiliary) material in the packaging can make the disposal of the 'empty' packaging as toxic waste mandatory.

This technique is applicable in new and existing installations. Depending on the geographic origin of the containers/drums, it might not be economically viable to use the technique.

### **Economics**

Economic data differ from site to site and depend on the conditions agreed with the supplier.

### **Driving force for implementation**

- prevention and recycling schemes for waste and packaging waste regulations.

### **Example plants**

- Clariant plant, Germany.

### **Reference literature**

[9, Vito, 2001]

## **4.2.2 Recycling of used 'soft' packaging materials**

### **Description**

Some companies (in Germany for example) operate a large number of collecting points where SIC producers may bring the emptied 'soft' packaging materials (made of e.g. plastic, wood, paper) from their suppliers of chemicals and additives for example. The collected materials are then recycled materially (e.g. paper mills, recycling plastics) or thermally oxidised (incinerated) by these companies.

### **Achieved environmental benefits**

- reduction of the amount of waste.

### **Cross-media effects**

If 'soft' packaging materials are returned without further cleaning, the following cross-media effect apply:

- release of contaminants to air and/or water at the place where the packaging is recycled (e.g. paper mill, incinerator) due to the residual contamination in the 'soft' packaging.

### **Applicability**

This procedure is applied for small and ‘soft’ packaging material which cannot be cleaned for re-use and is not contaminated with toxic/dangerous substances.

### **Economics**

The SIC companies that use the services of companies that recycle packaging materials pay licence fees for all their ‘soft’ packaging material sold in Germany.

### **Driving force for implementation**

Prevention and recycling schemes for waste and packaging waste regulations to fulfill the requirements of the ‘Verpackungsverordnung’ in Germany.

### **Example plants**

- Clariant plant, Germany.

### **4.2.3 Storage of liquid and liquefied gas**

The techniques considered generally to have the potential for achieving a high level of environmental protection in the SIC sector regarding the storage of liquid and liquefied gas are described in Section 4.1 of the ESB BREF [8, European IPPC Bureau, 2003].

### **4.2.4 Transfer and handling of liquid and liquefied gas**

The techniques considered generally to have the potential for achieving a high level of environmental protection in the SIC sector regarding the transfer and handling of liquid and liquefied gas are described in Section 4.2 of the ESB BREF [8, European IPPC Bureau, 2003].

### **4.2.5 Storage of solids**

The techniques considered generally to have the potential for achieving a high level of environmental protection in the SIC sector regarding the storage of solids are described in Section 4.3 of the ESB BREF [8, European IPPC Bureau, 2003].

### **4.2.6 Handling of solids**

The techniques considered generally to have the potential for achieving a high level of environmental protection in the SIC sector regarding the handling of solids are described in Section 4.4 of the ESB BREF [8, European IPPC Bureau, 2003].

## 4.3 Synthesis/reaction/calcination

### 4.3.1 Substitution of raw materials

#### Description

Because impurities in the feed stream contribute to waste generation, one of the most common substitutions is to use a higher purity feedstock.

This is accomplished by a combination of the following measures:

- working with suppliers to get a higher quality feed
- installing purification equipment at the installation
- substituting raw materials with less toxic and less water soluble materials to reduce water contamination, and with less volatile materials to reduce fugitive emissions.

#### Achieved environmental benefits

The substitution or elimination of some of the raw materials used in the production of SIC can result in the combination of the following benefits:

- reduction of the amount of waste generated
- reduction of emissions to the air
- reduction of emissions to the receiving water.

#### Cross-media effects

- use of energy and materials for purifying the raw materials.

#### Applicability

Applicability depends in particular on the cost of the substitute raw materials purchased, or on the cost of the purification equipment needed at the installation to purify the feedstock.

Substitution of raw materials may not be possible in the production of explosives (see Section 6.4) because known impurities can be of paramount importance in obtaining the required product under all security and safety conditions (e.g. effect on shape and size of crystals).

#### Economics

Cost of installing and running the purification equipment at the site.

Cost savings in the treatment of waste may result from the substitution or elimination of some of the raw materials used. However, this may be more than balanced by the increase of costs of a purer raw material.

#### Driving force for implementation

Production time is decreased as cleaning frequency is lower.

### Example plants

- CyPlus, Germany (see Section 6.5.4.10)
- phosphorus trichloride ( $\text{PCl}_3$ ) production plants (see Section 6.2.2.2.1.1 and Section 6.2.4.4): the use of phosphorus raw material ( $\text{P}_4$ ) with a low organic impurities content will result in a smaller amount of tarry carbon-mass remaining in the reactor per tonne of  $\text{PCl}_3$  produced.

### 4.3.2 Improving reactor efficiencies

#### Description

One of the most important parameters dictating the efficiency of the reactor is the quality of the mixing.

Improving the mixing is accomplished by a combination of the following measures:

- installing baffles in the reactor
- installing a suitable rpm motor for the agitator (in some cases it will mean installing a higher rpm motor, but in other cases a lower rpm motor – for example, in a viscous medium, higher rpm stirring may just decrease the mixing efficiency, e.g. due to the cavitation effect)
- putting in place a different mixing blade design
- installing multiple impellers
- pump recirculation
- adding a feed distributor to equalise residence time through the reactor
- adding feed streams at a point in time closer to the ideal reactant concentration.

#### Achieved environmental benefits

- reduction of raw materials consumption
- avoiding secondary reactions which form unwanted by-products.

#### Cross-media effects

- the shape and number of mixer plates, and the rpm of motor(s) have an effect on the consumption of energy.

#### Applicability

- generally applicable.

#### Economics

- cost of installing new equipment (e.g. baffles or higher rotation speed motor).

#### Driving force for implementation

Decreasing costs of production by achieving higher yield and generating less waste.

### 4.3.3 Improving catalyst systems

#### Description

The catalyst system plays a critical role in the effectiveness of chemical conversions in the reactor.

Improving the catalyst system is accomplished by a combination of the following measures:

- using alternative chemical make-ups and physical characteristics (in order to substantially improve the effectiveness and life of the catalyst system)
- using a catalyst system that allows the elimination or the reduction of by-product formation
- using noble metal catalysts instead of heavy metal catalysts (in order to eliminate or reduce the amount of waste water contaminated with heavy metals)
- using a more active form of a catalyst (in order to eliminate or reduce emissions and effluents during catalyst activation).

#### Achieved environmental benefits

- reduced consumption of catalysts
- elimination or reduction of residue/by-product formation
- reduction of the heavy metals content in waste water
- reduction or elimination of emissions and effluents during catalyst activation
- reduced energy demand of the reaction.

#### Cross-media effects

- none.

#### Applicability

Generally applicable in reaction processes that use a catalyst and/or can technically use a catalyst system.

### 4.3.4 Optimising processes

#### Description

Process changes that optimise reactions and the use of raw materials reduce the generation and release of waste. Many SIC installations use computer controlled systems which analyse the process continuously and respond more quickly and accurately than manual control systems. These systems are often capable of automatic start ups, shut downs, and product change-overs which can bring the process to a stable condition quickly, minimising the generation of off-specification products.

Other process optimisation measures include:

- equalising the reactor and storage tank vent lines during batch filling to minimise vent gas losses
- sequencing the addition of reactants and reagents to optimise yields, lower emissions and reduce waste (for discontinuous processes)
- optimising sequences to minimise cleaning operations and cross-contamination of subsequent batches (for discontinuous processes).

#### Achieved environmental benefits

- reduction of emissions to air
- reduction of emissions to water
- reduction of the consumption of water
- reduction of waste.

#### Cross-media effects

- none.

#### Applicability

- generally applicable.



## 4.4 Emissions abatement

This section is divided into:

- waste water treatment techniques (see Section 4.4.1)
- waste gas treatment techniques (see Section 4.4.2)
- combined waste water and waste gas treatment techniques (see Section 4.4.3)
- liquid (non-aqueous) and solid residues treatment techniques (see Section 4.4.4).

### 4.4.1 Waste water treatment techniques

[21, European IPPC Bureau, 2003]

In order to introduce a logical order in the description of waste water treatment techniques, the relationship between pollutant and respective typical treatment technology is taken as the reference, as pointed out in Section 2.5.3 and Table 2.3. The path of the contaminants to be controlled in the waste water is described in Figure 4.1.

The **first treatment step** for waste water and rainwater – and sometimes also the final step – is the separation of suspended solids from the water stream using **separation or clarification techniques**.

The separation or clarification techniques than can be used in the SIC sector are:

- sedimentation of solids (see Section 4.4.1.1.1)
- air flotation (see Section 4.4.1.1.2)
- filtration (see Section 4.4.1.1.3)
- membrane filtration (microfiltration or ultrafiltration) (see Section 4.4.1.1.4).

These techniques are mainly used in combination with other operations, either as a first or a final clarification step. As a first step they, for example, protect other waste water treatment facilities against damage, clogging or fouling by solids. As a final step they remove solids formed during a preceding treatment operation or process, or remove oil before further biological treatment. They often follow treatment techniques applied to soluble pollutants, when these are transferred into solids (e.g. precipitation).

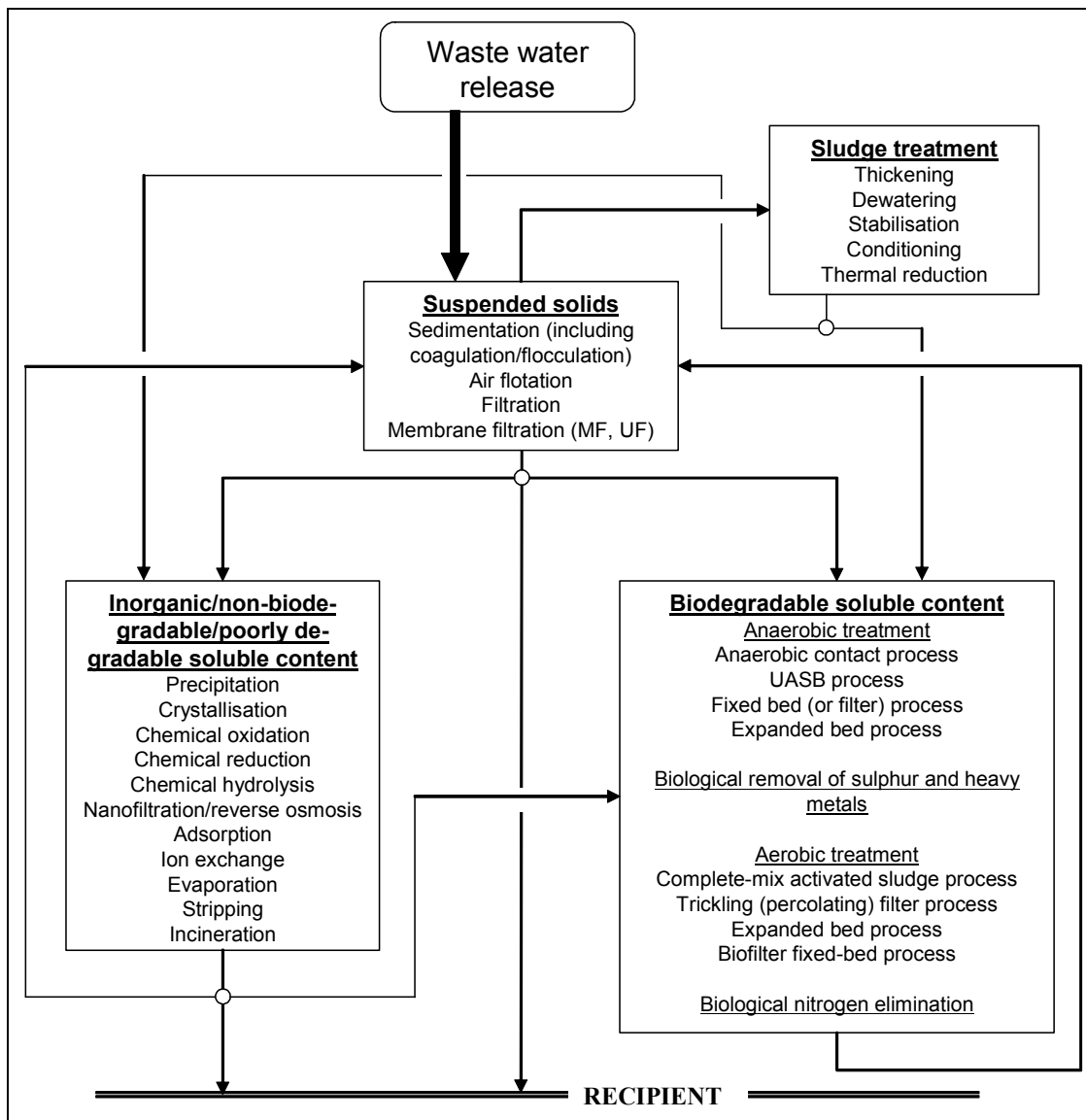

Figure 4.1: Waste water treatment techniques in relation to contaminants

Solid-free (oil-free) waste water can either be segregated into a biodegradable and a non-biodegradable part, or the contaminants responsible for the non-biodegradability may be separated before further treatment.

The treatment techniques for the non-biodegradable waste water part are based on **physical and/or chemical operations**, such as:

- precipitation/sedimentation/filtration (see Sections 4.4.1.2.1, 4.4.1.1.1, and 4.4.1.1.3)
- crystallisation (see Section 4.4.1.2.2)
- chemical oxidation (see Section 4.4.1.2.3)
- chemical reduction (see Section 4.4.1.2.4)
- nanofiltration/reverse osmosis (see Section 4.4.1.2.5)
- adsorption (see Section 4.4.1.2.6)
- ion exchange (see Section 4.4.1.2.7)
- evaporation (see Section 4.4.1.2.8)
- stripping (see Section 4.4.1.2.9)
- incineration (see Section 4.4.1.2.10).

After adequate treatment at the SIC installation, the waste water stream can either be discharged into a receiving water body, into a subsequent central biological WWTP or a municipal WWTP.

In the SIC sector, most of the waste water content is inorganic and non-biodegradable.

Biodegradable waste water – or the remaining waste water part after elimination of the cause of the non-biodegradability – normally undergoes treatment techniques, either centralised or decentralised, that are based on biological processes, such as:

- anaerobic biological
- aerobic biological
- nitrification/denitrification.

These biological processes are described in the CWW BREF [21, European IPPC Bureau, 2003].

The degraded waste water leaves the biological treatment plant and is piped to a clarification stage.

Many waste water treatment techniques require – or optionally use – treatment aids, which in most cases are chemicals, or the treatment media/equipment need regeneration, which can cause the release of chemicals. These aids or process steps might generate, generally depending on local conditions, a pollution that needs to be taken into account when considering the use of a treatment technique. Thus, an assessment of treatment aids and chemicals released from regeneration facilities and their fate during the whole process might be necessary in specific situations.

Almost all waste water treatment techniques have one thing in common: the production of solids during the process, which enables the pollutant to be separated from the aqueous medium, such as excess activated sludge or filtered or settled residue from filtration or sedimentation operations. If sludge is not recycled, it needs to be disposed of – i.e. external treatment and disposal – or treated on the site. Sludge treatment techniques are, e.g.

- thickening (see Section 4.4.4.1)
- dewatering (see Section 4.4.4.1)
- stabilisation (see Section 4.4.4.2)
- conditioning (see Section 4.4.4.2)
- thermal sludge reduction (see Section 4.4.4.3).

#### **4.4.1.1 Separation or clarification techniques**

##### **4.4.1.1.1 Sedimentation (including coagulation/flocculation) of solids**

###### **Description**

Sedimentation – or clarification – means the separation of suspended particles and floating material by gravitational settling. The settled solids are removed as sludge from the bottom, whereas floated material is skimmed from the water surface. When the particles cannot be separated by simple gravitational means, e.g. when they are too small, their density is too close to that of water or they form colloids, special chemicals are added to cause the solids to settle (e.g. aluminium sulphate, ferric sulphate, ferric chloride).

For additional information on the description, application and advantages and disadvantages of the technique, please refer to the CWW BREF [21, European IPPC Bureau, 2003].

### **Achieved environmental benefits**

- separation of heavy metals or other dissolved components after preceding precipitation (see Section 4.4.1.2.1), often with chemical support (e.g. flocculant), followed at the end by filtration processes (see Sections 4.4.1.1.3 and 4.4.1.1.4)
- clarifying collected rainwater from solid contents such as sand or dust in a sedimentation tank
- clarifying process waste water from reaction material such as emulsified metal compounds, supported by the addition of appropriate chemicals.

### **Cross-media effects**

- sedimented sludge and skimmed scum, if not suitable for recycling or other use otherwise, need to be disposed of as waste. Depending on the waste water origin, this waste might contain hazardous compounds to be treated accordingly. These compounds can be carbonates, fluorides, sulphides or hydroxides (or oxides) of heavy metals, oily scum, etc.
- consumption of chemicals (coagulant/flocculant)
- consumption of energy
- noise and odour may be an issue.

### **Operational data**

- see the CWW BREF [21, European IPPC Bureau, 2003].

### **Applicability**

- generally applicable.

### **Economics**

- see the CWW BREF [21, European IPPC Bureau, 2003].

### **Example plants**

- OMG in Harjavalta, Finland.

### **Reference literature**

CWW BREF [21, European IPPC Bureau, 2003].

#### 4.4.1.1.2 Air flotation

##### Description

Flotation is a process where solid or liquid particles or particulates are separated from the waste water phase by becoming attached to air bubbles. The buoyant particles accumulate at the water surface and are collected with skimmers.

Flocculant additives, such as aluminium and ferric salts, activated silica and various organic polymers, are commonly used to support the flotation process. Their function, besides coagulation and flocculation, is to create a surface or a structure able to absorb or entrap the air bubbles.

For additional information on the description, application, limits/restrictions and advantages and disadvantages of the technique, please refer to the CWW BREF [21, European IPPC Bureau, 2003].

##### Achieved environmental benefits

- separation of heavy metals from waste water
- removal of pigments from respective production waste water
- recovery of product or raw material, e.g. silver halides from production of photographic chemicals.

##### Cross-media effects

- the separated material, if not recyclable, is disposed of as waste. The amount depends on the material to be removed and the amount of coagulant and flocculant chemicals. Those can be quite different, according to the respective application of air flotation
- consumption of chemicals (coagulant and flocculant)
- consumption of energy.

##### Applicability

- generally applicable.

##### Economics

- see the CWW BREF [21, European IPPC Bureau, 2003].

##### Reference literature

CWW BREF [21, European IPPC Bureau, 2003].

### 4.4.1.1.3 Filtration

#### Description

Filtration describes the separation of solids from waste water effluents passing through a porous medium. Filters typically require a cleaning operation – backwashing – with reverse flow of fresh water and the accumulated material returned to the sedimentation tank (see Section 4.4.1.1.1).

Commonly used types of filter systems are, e.g.

- the granular-medium filter, or sand filter, which is widely used as a waste water treatment device (the medium of sand filters need not be literally sand), mainly used with a low solids content
- the gravity drum filter, used for sewage treatment and removal of activated sludge flocs, its efficiency dependent on the screen fabric
- the rotary vacuum filter, well suited to pre-coat filtration, which is used for oily sludge dewatering and slop de-emulsification
- the membrane filter (see Section 4.4.1.1.4)
- the belt filter press, which is largely used for sludge dewatering, but also for liquid/solid separation operations
- the filter press, which is usually used for sludge dewatering, but also for liquid/solid operations, suitable for a high solids content.

In waste water treatment, filtration is frequently used as the final separation stage after sedimentation processes (see Section 4.4.1.1.1) or flotation (see Section 4.4.1.1.2), if low emissions of particulates are wanted.

For additional information on the description, application, limits/restrictions and advantages and disadvantages of the technique, please refer to the CWW BREF [21, European IPPC Bureau, 2003].

#### Achieved environmental benefits

- separation of floc, heavy metal hydroxides, etc. after sedimentation, to cope with discharge requirements
- dewatering of sludge, floating material, etc.

#### Cross-media effects

- consumption of water for backwashing
- filter aids
- energy
- noise and odour may be an issue.

#### Applicability

- generally applicable.

#### Economics

- see the CWW BREF [21, European IPPC Bureau, 2003].

#### Reference literature

CWW BREF [21, European IPPC Bureau, 2003].

#### 4.4.1.1.4 Membrane filtration (microfiltration or ultrafiltration)

##### Description

Microfiltration (MF) and Ultrafiltration (UF) are membrane filtration processes that segregate a liquid that permeates through a membrane into permeate, which passes the membrane, and concentrate, which is retained. The driving force of the process is the pressure difference across the membrane.

Membranes used for MF and UF are ‘pore type’ membranes which operate like sieves. The solvent and particles of molecular size can pass the pores, whereas suspended particles, colloidal particles, bacteria, viruses, and even larger macromolecules are held back.

For additional information on the description, application, limits/restrictions and advantages and disadvantages of the technique, please refer to the CWW BREF [21, European IPPC Bureau, 2003].

##### Achieved environmental benefits

Membrane filtration (MF and UF) is applied when a solid-free waste water for downstream facilities, e.g. reverse osmosis, or the complete removal of hazardous contaminants such as heavy metals, is desired. The choice between MF and UF depends on the particle size.

##### Cross-media effects

- consumption of membrane material
- membrane treatment produces a residue (concentrate) of approximately 10 % of the original feed volume, in which the target substances are present at levels approximately 10 times their concentration in the original feed. An assessment should be made as to whether this residue can be disposed of
- consumption of chemicals (e.g. antifouling)
- consumption of energy.

##### Applicability

- generally applicable.

##### Economics

- see the CWW BREF [21, European IPPC Bureau, 2003].

##### Reference literature

CWW BREF [21, European IPPC Bureau, 2003].

### 4.4.1.2 Physical and/or chemical techniques

#### 4.4.1.2.1 Precipitation

##### Description

Precipitation is a chemical way to form particulates that can be separated by an additional process, such as sedimentation (see Section 4.4.1.1.1), air flotation (see Section 4.4.1.1.2), filtration (see Section 4.4.1.1.3) and if necessary followed by microfiltration or ultrafiltration (see Section 4.4.1.1.4). Fine separation by membrane techniques might be necessary to protect downstream facilities or to prevent the discharge of hazardous particulates. It might also be a useful technique to remove colloidal precipitates (e.g. heavy metal sulphides).

A precipitation facility usually consists of one or two stirred mixing tanks, where the agent and possibly other chemicals are added, a sedimentation tank and storage tanks for the chemical agents. If needed – as mentioned above – further treatment equipment is added. The sedimentation tank might be replaced downstream by other sludge collecting systems.

For additional information on the description, application and advantages and disadvantages of the technique, please refer to the CWW BREF [21, European IPPC Bureau, 2003].

##### Achieved environmental benefits

When used in conjunction with other techniques, precipitation enables:

- reduction of the heavy metals, sulphates, and fluorides concentration in the released waste water
- possibility to recover heavy metals and to recycle them back into the SIC production or in productions outside of the SIC installation.

##### Cross-media effects

The main cross-media effects are:

- consumption of precipitation chemicals (e.g. lime, dolomite, sodium hydroxide, sodium carbonate, sulphuric acid), flocculants and/or coagulants
- consumption of chemicals to regulate the pH (e.g. NaOH, H<sub>2</sub>SO<sub>4</sub>)
- the precipitants usually have to be disposed of as sludge.

Noise and/or odour can also be an issue. For more information on this, please refer to the CWW BREF [21, European IPPC Bureau, 2003].

##### Operational data

Operational data are presented in Table 4.2.



Parameter	Performance rate (%)	Emission level (mg/l)	Precipitation chemical	Flocculants	Coagulants	Remarks
Aluminium		0 – 5.8 <sup>7</sup>				
Cadmium		<0.01 <sup>7</sup>				
Chromium (III)						
Chromium (VI)		<0.1 <sup>5</sup>				
Total chromium		0.1 <sup>3</sup> 0.08 <sup>4</sup> <0.05 <sup>7</sup> 1 – 2.5 <sup>5</sup>				
Cobalt		0.07 <sup>4</sup>				
Copper		0.01 <sup>4</sup> 0 – 0.08 <sup>7</sup>				
Fluoride		<50 <sup>6</sup>	Ca(OH) <sub>2</sub>			In the absence of free NH <sub>3</sub> or other Ca <sup>2+</sup> complexing agents
Iron						
Lead	99.6 <sup>1</sup> – 99.95 <sup>1</sup> 46.6 <sup>2</sup> – 76.4 <sup>2</sup>	<0.05 <sup>7</sup> 0.5 <sup>3</sup> 0.05 <sup>4</sup> 5 <sup>1</sup> – 15 <sup>1</sup> 0.002 <sup>2</sup> – 0.004 <sup>2</sup>	Na <sub>2</sub> CO <sub>3</sub> <sup>1</sup> , H <sub>2</sub> SO <sub>4</sub> <sup>1</sup>		Fe(III) and Al salts	
Mercury						
Nickel						
Phosphate						
Sulphate		2000 <sup>3</sup> 92 – 530 <sup>7</sup>				
Tin						
Zinc		0.13 <sup>4</sup> 0.08 – 0.46 <sup>7</sup>				

<sup>1</sup> Values achieved at a SIC installation before discharge to a WWTP when lead is the only inorganic pollutant in the waste water  
<sup>2</sup> Values achieved at a SIC installation when lead is present together with chloride, fluoride, boron, vanadium, manganese and zinc in the waste water  
<sup>3</sup> Annual average from a SIC installation after pretreatment and before discharge to a biological WWTP  
<sup>4</sup> Measurement from a SIC installation after pretreatment and before discharge to a municipal WWTP  
<sup>5</sup> From a SIC installation after pretreatment and before discharge to a central WWTP  
<sup>6</sup> TWG comment  
<sup>7</sup> See Table 6.10

**Table 4.2: Operational data associated with the use of precipitation techniques**

Achievable emission levels for heavy metals vary greatly, depending on the particular situation, such as:

- removal of a single heavy metal species from an inorganic waste water matrix
- removal of a heavy metal mix from an inorganic waste water matrix
- removal of heavy metals from an organic waste water matrix with a tendency for formation of metal complexes, e.g. dye agents.

#### Applicability

- generally applicable.

### Example plants

- UEB plant in Galdácano, Spain
- Colorobbia plant, Italy.

### Reference literature

CWW BREF [21, European IPPC Bureau, 2003].

#### 4.4.1.2.2 Crystallisation

##### Description

Crystallisation is closely related to precipitation. In contrast to precipitation, the precipitate is not formed by a chemical reaction in the waste water, but is produced on seed material such as sand or minerals, working in a fluidised-bed process – a pellet reactor system. The pellets grow and move towards the reactor bottom. The driving force of the process is the reagent dosage and pH adjustment. No waste sludge arises.

For additional information on the description, application and advantages and disadvantages of the technique, please refer to the CWW BREF [21, European IPPC Bureau, 2003].

##### Achieved environmental benefits

- abatement or recovery of heavy metals.

##### Cross-media effects

- consumption of reagents to form the precipitates
- presence of the reagent in the waste water
- noise.

##### Operational data

- see the CWW BREF [21, European IPPC Bureau, 2003].

##### Applicability

- generally applicable.

##### Economics

- see the CWW BREF [21, European IPPC Bureau, 2003].

### Reference literature

CWW BREF [21, European IPPC Bureau, 2003].

#### 4.4.1.2.3 Chemical oxidation

##### Description

Chemical oxidation is the conversion of pollutants by chemical oxidation agents other than oxygen/air or bacteria to similar but less harmful or hazardous compounds and/or to short-chained and easily biodegradable organic components.

Chemical oxidation is normally applied when the waste water contains contaminants that are not readily biodegradable, or not biodegradable at all (e.g. inorganic components), might disturb the biological or physico-chemical process in a downstream WWTP or have properties too harmful to allow them to be released into a common sewerage system.

Oxidation reactions with active oxygen (ozone, hydrogen peroxide), often accompanied by UV irradiation, are used, e.g. to treat leachates from landfills or remove refractory COD, odorous components or colour pigments. Oxidation reactions are used to treat waste waters loaded with cyanides (see Section 6.5.4.1).

For additional information on the description, application and advantages and disadvantages of the technique, please refer to the CWW BREF [21, European IPPC Bureau, 2003].

##### Achieved environmental benefits

- conversion of pollutants to less harmful or hazardous compounds.

##### Cross-media effects

- use of oxidation agent (e.g. hydrogen peroxide).

##### Operational data

- see the CWW BREF [21, European IPPC Bureau, 2003].

##### Applicability

- generally applicable.

##### Economics

- see the CWW BREF [21, European IPPC Bureau, 2003].

##### Example plants

- CyPlus plant, Germany.

##### Reference literature

CWW BREF [21, European IPPC Bureau, 2003].

### 4.4.1.2.4 Chemical reduction

#### Description

Chemical reduction is the conversion of pollutants by chemical reduction agents to similar but less harmful or hazardous compounds. Common chemical reducing agents are, e.g.

- sulphur dioxide
- sodium hydrogen sulphite/metabisulphite
- ferrous sulphate
- sodium sulphide and sodium hydrogen sulphide
- urea or amidosulphonic acid (at a low pH).

They are brought into contact with the waste species under appropriate pH and concentration conditions. Chemical reduction normally results in products that can be treated more easily in downstream treatment facilities such as chemical precipitation. Chemical reduction is used to treat waste waters loaded with chromium (VI) in the production of some speciality inorganic pigments (see Section 6.1).

For additional information on the description, application and advantages and disadvantages of the technique, please refer to the CWW BREF [21, European IPPC Bureau, 2003].

#### Achieved environmental benefits

- conversion of contaminants to less harmful or hazardous compounds.

Examples of such contaminants are:

- chromium (VI), which is reduced to chromium (III)
- chlorine or hypochlorite, which are reduced to chloride
- hydrogen peroxide, which is reduced to water and oxygen
- nitrite, using urea or amidosulphonic acid at a low pH.

#### Cross-media effects

- use of reduction agent (e.g. sulphur dioxide, ferrous sulphate).

#### Applicability

- generally applicable.

#### Economics

- see the CWW BREF [21, European IPPC Bureau, 2003].

#### Reference literature

CWW BREF [21, European IPPC Bureau, 2003].

#### 4.4.1.2.5 Nanofiltration (NF)/Reverse Osmosis (RO)

##### Description

A membrane process is the permeation of a liquid through a membrane, to be segregated into permeate that passes the membrane and concentrate that is retained. The driving force of this process is the pressure difference across the membrane.

NF and RO membranes can hold back all particles down to the size of organic molecules and even ions. Provided that the feed is particle-free, these membranes are mainly used when complete recycling of permeate and/or concentrate is desired.

NF is applied to remove larger organic molecules and multivalent ions in order to recycle and re-use the waste water or reduce its volume and simultaneously increase the concentration of contaminants to such an extent that subsequent destruction processes are feasible.

RO is a process to separate water and the dissolved constituents down to ionic species. It is applied when a high grade of purity is required. The segregated water phase is recycled and re-used. An example of this is the final removal of heavy metals.

NF and RO are often used in combination with post-treatment techniques for the permeate, e.g. ion exchange or GAC adsorption.

For additional information on the description, application, advantages/disadvantages and limits/restrictions of the technique, please refer to the CWW BREF [21, European IPPC Bureau, 2003].

##### Achieved environmental benefits

- removal of heavy metals from waste water.

##### Applicability

- generally applicable.

##### Economics

- see the CWW BREF [21, European IPPC Bureau, 2003].

##### Reference literature

CWW BREF [21, European IPPC Bureau, 2003].

#### 4.4.1.2.6 Adsorption

##### Description

Adsorption is the transfer of soluble substances (solutes) from the waste water phase to the surface of solid, highly porous, particles (the adsorbent). The adsorbent has a finite capacity for each compound to be removed. When this capacity is exhausted, the adsorbent is 'spent' and has to be replaced by fresh material. The spent adsorbent either has to be regenerated or incinerated.

The most common adsorbents for adsorptive waste water purification in the SIC sector is activated carbon. It is used as a granulate (GAC) in columns or as a powder (PAC) dosed to a treatment tank or basin. Other common inorganic adsorbents are activated alumina or granular ferric hydroxide, suitable for removal of anions (e.g. phosphate, arsenate, antimonite).

Since the adsorbent active surface is often liable to clogging and blockage, the waste water needs to be free from solid content as completely as possible, which often makes an upstream filtration step necessary.

For additional information on the description, application, advantages/disadvantages and limits/restrictions of the technique, please refer to the CWW BREF [21, European IPPC Bureau, 2003].

##### Achieved environmental benefits

- removal of heavy metals from waste water
- removal of COD and particles causing coloration of waste water.

##### Cross-media effects

- consumption of adsorbent (e.g. activated carbon)
- consumption of energy and/or chemicals for regenerating the adsorbent
- release of contaminants to water and/or air during the regeneration process
- disposal of the adsorbent if it cannot be regenerated.

For additional information on the cross-media effects please refer to the CWW BREF [21, European IPPC Bureau, 2003].

##### Operational data

Operational data are presented in Table 4.3.

Parameter	Performance rate	Emission level	Remarks
	%	mg/l	
COD	60 <sup>1</sup>	<600 <sup>1</sup>	GAC, room temperature
<sup>1</sup> Data from UEB, Galdacano plant, Spain			

**Table 4.3: Operational data associated with the use of the adsorption technique**

### **Applicability**

- generally applicable.

### **Economics**

- see the CWW BREF [21, European IPPC Bureau, 2003].

### **Driving force for implementation**

Reduction of COD levels and removing particles causing coloration of waste water.

### **Example plants**

- UEB plant in Galdácano, Spain.

### **Reference literature**

CWW BREF [21, European IPPC Bureau, 2003].

### 4.4.1.2.7 Ion exchange

#### Description

Ion exchange is the removal of undesired or hazardous ionic constituents of waste water and their replacement by more acceptable ions from an ion exchange resin, where they are temporarily retained and afterwards released into a regeneration or backwashing liquid.

Ion exchange is feasible as an end-of-pipe treatment, but its greatest value lies in its recovery potential. It is commonly used as an integrated operation in waste water treatment, e.g. to recover rinse-water and process chemicals.

For additional information on the description, application, advantages/disadvantages and limits/restrictions of the technique, please refer to the CWW BREF [21, European IPPC Bureau, 2003].

#### Achieved environmental benefits

- removal of heavy metal ions (cationic or anionic, e.g.  $\text{Cr}_3^+$  or cadmium and its compounds, with low feed concentrations,  $\text{CrO}_4^{2-}$  also with high feed concentrations) from waste water
- ionisable inorganic compounds, such as  $\text{H}_3\text{BO}_3$ .

#### Cross-media effects

- consumption of ion exchange resins
- consumption of energy and chemicals for regenerating the resins
- release of contaminants to water during the regeneration process.

For additional information on the cross-media effects, please refer to the CWW BREF [21, European IPPC Bureau, 2003].

#### Applicability

- generally applicable.

#### Economics

- see the CWW BREF [21, European IPPC Bureau, 2003].

#### Reference literature

CWW BREF [21, European IPPC Bureau, 2003].



#### 4.4.1.2.8 Evaporation

##### Description

Evaporation of waste water is a distillation process where water is the volatile substance, leaving the concentrate as the bottom residue to be disposed of. The aim of this operation is to reduce the volume of waste water or to concentrate mother liquors. The volatile steam is collected in a condenser and the condensed water is, if needed after subsequent treatment, recycled.

Operating under vacuum decreases the boiling temperature and enables the recycling of substances that would otherwise decompose.

When material recovery is the main purpose, a pretreatment operation is required before evaporation can be started. Examples of pretreatments are:

- addition of acids, bases, etc. to lower the volatility of molecular compounds
- separation of insoluble, free liquid phases, e.g. oil
- chemical/physical operations to separate heavy metals and/or other solids.

Further treatment, e.g. incineration, after evaporation is required, if the concentrate is not recycled.

For additional information on the description, application, advantages/disadvantages and limits/restrictions of the technique, please refer to the CWW BREF [21, European IPPC Bureau, 2003].

##### Achieved environmental benefits

- recovery of valuable substances
- removal of contaminants from the waste water effluent.

##### Cross-media effects

- use of energy.

For additional information on the cross-media effects, please refer to the CWW BREF [21, European IPPC Bureau, 2003].

##### Applicability

- generally applicable.

##### Economics

- see the CWW BREF [21, European IPPC Bureau, 2003].

##### Example plants

- Austin Plant, Czech Republic (see Section 6.4.4.2).

##### Reference literature

CWW BREF [21, European IPPC Bureau, 2003].

### 4.4.1.2.9 Stripping

#### Description

Waste water stripping is an operation in which waste water is brought into contact with a high flow of a gas current in order to transfer volatile pollutants from the water phase to the gas phase. The pollutants are removed from the stripping gas so it can be recycled into the process and re-used. Volatile organics and inorganics are transferred from waste water to waste gas, greatly increasing the surface area of the contaminated water exposed. Water evaporation, however, decreases the temperature of the waste water, thus decreasing the volatility of the contaminants.

Stripping is applied to separate volatile contaminants from water, e.g.

- ammonia and hydrogen sulphide, their volatility is strongly dependent on temperature and pH, thus pH control is essential (pH >9.5 with ammonia, pH 2 to 3 with hydrogen sulphide)
- ammonia and hydrogen sulphide together in a two-stage steam stripping unit.

For additional information on the description, application, advantages/disadvantages and limits/restrictions of the technique, please refer to the CWW BREF [21, European IPPC Bureau, 2003].

#### Achieved environmental benefits

- recovery of valuable substances
- removal of contaminants from the waste water effluent.

#### Cross-media effects

- consumption of energy
- consumption of chemicals to adjust pH
- consumption of antifouling agents.

Stripping is not used as an individual process. It needs at least downstream gas treatment. The removed volatiles are either recycled to a production process or treated (scrubbing, adsorption, thermal or catalytic oxidation). Generally speaking, the treatment of the stripping gas is an essential process step and sometimes more complicated than the stripping operation itself. To obtain an efficient treatment in total, both the stripping stage and the stripping gas treatment have to be carefully adjusted to each other.

For additional information on the cross-media effects, please refer to the CWW BREF [21, European IPPC Bureau, 2003].

#### Applicability

- generally applicable.

#### Economics

- see the CWW BREF [21, European IPPC Bureau, 2003].

#### Reference literature

CWW BREF [21, European IPPC Bureau, 2003].

#### 4.4.1.2.10 Incineration

##### Description

Waste water incineration is the oxidation with air of organic and inorganic waste water contaminants and the simultaneous evaporation of the aqueous part at normal pressure and a temperature range between 730 and 1200 °C, or below that range when catalysts are used. In the chemical industry, waste water incineration is often operated centrally or, as co-incineration, in waste combustion plants. Reaction products are carbon dioxide, water and other inorganic compounds (nitrogen oxides, sulphur oxides, hydrogen halides, phosphates, heavy metal compounds), depending on the contaminants present.

For additional information on the description, application, advantages/disadvantages and limits/restrictions of the technique, please refer to the CWW BREF [21, European IPPC Bureau, 2003].

##### Achieved environmental benefits

- removal of contaminated waste water.

##### Cross-media effects

- consumption of supporting fuel (when the process cannot be operated autothermally)
- generation of waste gas from incineration (combustion exhaust gas potentially containing HCl, SO<sub>x</sub>, NO<sub>x</sub>, etc.).

For additional information on the cross-media effects, please refer to the CWW BREF [21, European IPPC Bureau, 2003].

##### Applicability

The technique applies when the contaminated waste water:

- is not readily biodegradable
- might disturb the biological process in a downstream biological WWTP
- have properties too harmful to be released into an ordinary sewerage system.

##### Economics

- see the CWW BREF [21, European IPPC Bureau, 2003].

##### Example plants

- LANXESS production of phosphorus compounds in Leverkusen, Germany.

##### Reference literature

CWW BREF [21, European IPPC Bureau, 2003].

## 4.4.2 Waste gas treatment techniques

### 4.4.2.1 Waste gas treatment techniques to abate particulate matter

Dust has been recognised as a key environmental issue in the production of SIC substances (see Section 1.3). The main sources of dust in the production of SIC substances and the main techniques used in the SIC sector to abate dust are presented in Figure 4.2. The dust characteristics as well as the properties of the gas carrying the dust (both shown in Figure 4.2) are determining factors to take into account when choosing dust abatement techniques.

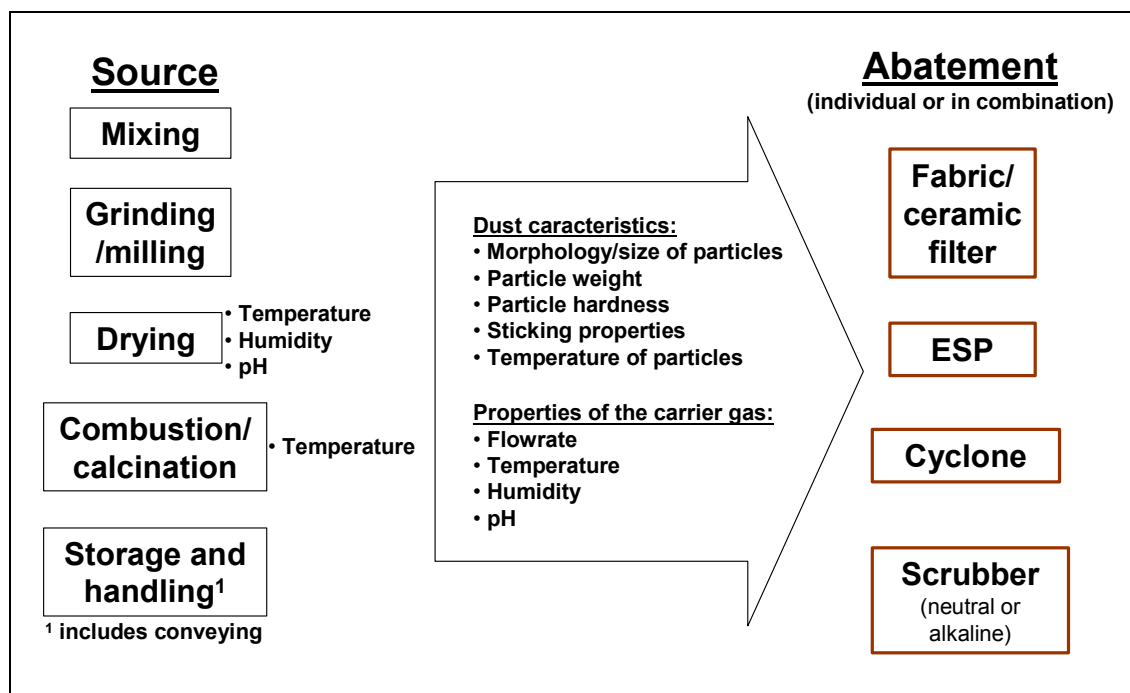

Figure 4.2: Main sources of dust and abatement techniques used in the SIC sector

#### 4.4.2.1.1 Separators

##### Description

The waste gas stream is passed into a chamber where the dust, aerosols and/or droplets are separated from the gas under the influence of gravity/mass inertia, the effect increased by reducing the gas velocity by design means, e.g. baffles, lamellae or metal gauze.

A separator is usually installed as a preliminary step to various dust filter systems, scrubbers, cooling towers, etc. It is used, e.g. to prevent entrainment of the washing liquid with the purified waste gas and/or to remove abrasive particles. It is not applicable to treat particulates in flue-gas.

For additional information on the description, application, advantages/disadvantages and limits/restrictions of the technique, please refer to the CWW BREF [21, European IPPC Bureau, 2003].

##### Achieved environmental benefits

- prevent entrainment of the washing liquid with the purified waste gas
- remove abrasive particles to protect dust filter systems.

### Cross-media effects

- residues are the separated dust and/or the separated droplets which have to be disposed of when re-use/recirculation is not possible. Depending on its source, the separated dust might be contaminated with a toxic and hazardous content which needs to be considered for further treatment or disposal
- consumption of energy for powering fans.

### Operational data

Operational data are presented in Table 4.4.

Parameter	Performance rate	Emission level	Remarks
	%	mg/l	
PM	10 – 90 <sup>1</sup>		Dependent on PM size

<sup>1</sup> From the CWW BREF

**Table 4.4: Operational data associated with the use of the separator technique**

### Applicability

- generally applicable.

### Economics

- see the CWW BREF [21, European IPPC Bureau, 2003].

### Reference literature

CWW BREF [21, European IPPC Bureau, 2003].

### 4.4.2.1.2 Cyclones

#### Description

Cyclones use inertia to remove particles from the gas stream, imparting centrifugal forces, usually within a conical chamber. They operate by creating a double vortex inside the cyclone body. The incoming gas is forced into circular motion down the cyclone near the inner surface of the cyclone tube. At the bottom, the gas turns and spirals up through the centre of the tube and out of the top of the cyclone. Particles in the gas stream are forced towards the cyclone walls by the centrifugal force of the spinning gas but are opposed by the fluid drag force of the gas travelling through and out of the cyclone. Large particles reach the cyclone wall and are collected in a bottom hopper, whereas small particles leave the cyclone with the exiting gas.

For additional information on the description, application, advantages/disadvantages and limits/restrictions of the technique, please refer to the CWW BREF [21, European IPPC Bureau, 2003].

#### Achieved environmental benefits

Cyclones are used to control particulate material, and primarily for PM >10 µm. There are, however, high efficiency cyclones designed to be effective even for PM<sub>2.5</sub>.

Cyclones themselves are generally not adequate to meet air pollution regulations, but they serve a purpose as precleaners for more expensive final control devices such as fabric filters (see Section 4.4.2.1.5) or electrostatic precipitators (see Section 4.4.2.1.4). They are extensively used after spray drying operations and after crushing, grinding and calcining operations.

#### Cross-media effects

- if it is not recycled back into production, dust recuperated is emitted as a residue and has to be disposed of. The amount depends on the dust load of the waste gas. Depending on its source, the separated dust can be contaminated with toxic and/or hazardous substances.

#### Applicability

- generally applicable.

#### Economics

- see the CWW BREF [21, European IPPC Bureau, 2003].

#### Example plants

- COLOROBBIA plant, Italy.

#### Reference literature

CWW BREF [21, European IPPC Bureau, 2003].

#### 4.4.2.1.3 Wet dust scrubber

##### Description

Wet dust scrubbing is a variation of wet gas scrubbing (see Section 4.4.2.2.4), using the same or equivalent techniques to abate or recover particulate matter additionally to gaseous compounds.

The different scrubbers operated are mainly:

- fibrous packing scrubbers
- moving bed scrubbers
- plate scrubbers
- spray towers
- impingement entrainment scrubbers
- venturi scrubbers.

For additional information on the description, application, advantages/disadvantages and limits/restrictions of the technique, please refer to the CWW BREF [21, European IPPC Bureau, 2003].

##### Achieved environmental benefits

- abate or recover PM.

##### Cross-media effects

- consumption of water
- consumption of energy.

##### Operational data

Operational data are presented in Table 4.5.

Parameter	Performance rate	Emission level	Remarks
	%	mg/l	
PM	50 – >99 <sup>1</sup>		Dependent on scrubber type used
VOC	50 – >99 <sup>1</sup>		Dependent on scrubber type used
SO <sub>2</sub>	80 – >99 <sup>1</sup>		
HCl	90 <sup>1</sup>		Achieved with venturi scrubbers
HF	90 <sup>1</sup>		Achieved with venturi scrubbers
NH <sub>3</sub>	94 – 99 <sup>1</sup>		
<sup>1</sup> From the CWW BREF			

**Table 4.5: Operational data associated with the use of wet dust scrubbers**

##### Applicability

Generally applicable.

### **Economics**

See the CWW BREF [21, European IPPC Bureau, 2003].

### **Example plants**

- OMG in Harjavalta, Finland.

### **Reference literature**

CWW BREF [21, European IPPC Bureau, 2003].



#### 4.4.2.1.4 Electrostatic precipitator (ESP)

##### Description

An ESP is a particulate control device that uses electrical forces to move particles entrained within a waste gas stream onto collector plates. The entrained particles are given an electrical charge when they pass through a corona where gaseous ions flow. Electrodes in the centre of the flow lane are maintained at high voltage and generate the electrical field that forces the particles to the collector walls.

The pulsating DC voltage required is commonly in the range of 20 – 100 kV. Ion blast ESPs operate typically in the range of 100 – 150 kV to provide superior separation efficiency – particularly in the sub-micron area.

For additional information on the description, application, advantages/disadvantages and limits/restrictions of the technique, please refer to the CWW BREF [21, European IPPC Bureau, 2003].

##### Achieved environmental benefits

ESPs are applied to remove particulate matter down to PM<sub>2.5</sub> and smaller and hazardous air pollutants, such as most metals (with the notable exception of mercury).

##### Cross-media effects

- consumption of energy.

##### Operational data

Operational data are presented in Table 4.6.

Parameter	Performance rate	Emission level	Remarks
	%	mg/Nm <sup>3</sup>	
PM	99 – 99.2 <sup>1</sup>		
PM <sub>10</sub>	97.1 – 99.4 <sup>1</sup>		
PM <sub>2.5</sub>	96 – 99.2 <sup>1</sup>		
Dust		5 – 15 <sup>1</sup>	For well designed and properly sized ESPs
<sup>1</sup> From the CWW BREF			

Table 4.6: Operational data associated with the use of ESP

##### Applicability

- generally applicable.

##### Economics

- see the CWW BREF [21, European IPPC Bureau, 2003].

##### Reference literature

CWW BREF [21, European IPPC Bureau, 2003].

#### 4.4.2.1.5 Fabric and ceramic filters

##### Description

In a fabric filter, waste gas is passed through a tightly woven or felted fabric, causing particulate matter to be collected on the fabric by sieving or other mechanisms. Fabric filters can be in the form of sheets, cartridges or bags (the most common type) with a number of the individual fabric filter units housed together in a group. The dust cake that forms on the filter can significantly increase the collection efficiency.

Fabric filters are useful to collect particulate matter with electrical resistivities either too low or too high for ESPs. The addition of a baghouse downstream of an ESP has been found to achieve very low particulate emissions.

When the waste gas loading consists of relatively large particulates, upstream mechanical collectors such as cyclones, ESPs or spray coolers may be used to reduce the load for the fabric filter, especially at high inlet concentrations.

For additional information on the description, application, advantages/disadvantages and limits/restrictions of the technique, please refer to the CWW BREF [21, European IPPC Bureau, 2003].

##### Achieved environmental benefits

Primarily the fabric filter is used to remove particulate matter down to  $<PM_{2.5}$  and hazardous air pollutants in particulate form ( $PM_{HAP}$ ), such as metals (with the exception of mercury). In combination with injection systems (including adsorption, dry lime/sodium bicarbonate injection and semi-dry lime injection) upstream of the baghouse, it can also be applied to remove specific gaseous contaminants.

##### Cross-media effects

- consumption of filter fabric
- consumption of energy.

##### Operational data

Operational data are presented in Table 4.7.

Parameter	Performance rate	Emission level	Remarks
	%	mg/Nm <sup>3</sup>	
PM	99 – 99.9 <sup>1</sup>	<1 – 10 <sup>1</sup>	Depends on the type of filter used
<sup>1</sup> From the CWW BREF			

Table 4.7: Operational data associated with the use of fabric and ceramic filters

##### Applicability

- generally applicable.

### **Economics**

- see the CWW BREF [21, European IPPC Bureau, 2003].

### **Example plants**

- COLOROBRIA plant, Italy.

### **Reference literature**

CWW BREF [21, European IPPC Bureau, 2003].

**4.4.2.1.6 Two-stage dust filter****Description**

The two-stage dust filter contains metal gauze as filter material. A filter cake is built up in the first filtration stage and the actual filtration takes place in the second stage. Depending on the pressure drop across the filter, the second stage is cleaned and the system switches between the two stages (step one becomes the second and vice versa). A mechanism to remove the filtered dust is integrated in the system. The dust drops to the bottom of the chamber where it has to be removed.

Since metal gauze has a larger load capacity than a fabric filter, less filter area (i.e. less filter material) is required. This advantage, however, is usually eliminated because of the two-stage system.

For additional information on the description, application, advantages/disadvantages and limits/restrictions of the technique, please refer to the CWW BREF [21, European IPPC Bureau, 2003].

**Achieved environmental benefits**

Primarily the two-stage dust filter is operated to remove particulate matter. In combination with injection systems (including adsorption, semi-dry lime injection), it can also be used to remove specific gaseous contaminants.

**Cross-media effects**

- if it is not recycled back into production, the separated dust has to be disposed of accordingly. This type of dust might be classified as hazardous waste
- consumption of filter material
- consumption of compressed air for cleaning
- consumption of energy.

**Operational data**

Operational data are presented in Table 4.8.

Parameter	Performance rate	Emission level	Remarks
	%	mg/Nm <sup>3</sup>	
PM		≈ 1 <sup>1</sup>	Virtually independent of inlet
<sup>1</sup> From the CWW BREF			

**Table 4.8: Operational data associated with the use of two-stage dust filters**

**Applicability**

- generally applicable.

**Economics**

- see the CWW BREF [21, European IPPC Bureau, 2003].

**Reference literature**

CWW BREF [21, European IPPC Bureau, 2003].

#### 4.4.2.1.7 Absolute High Efficiency Particulate Arrestation (HEPA) filter

##### Description

The filter medium is paper or matted glass fibre with a high packing density. The waste gas stream is passed through the filter medium, where particulate matter is collected. The dust cake that forms on the filter medium can increase collection efficiency.

HEPA filters are applicable to submicron particulate matter between  $PM_{0.12}$  and  $PM_{0.3}$  as well as hazardous air pollutants that are in particulate form, such as most heavy metals (except mercury).

HEPA filters are best applied in situations where a high collection efficiency of submicron particulate matter is required, and where toxic and/or hazardous particulate matter cannot be cleaned by other filters, e.g. chemical and biological material. They are installed as the final component in a collection system, downstream from other devices such as ESP or bag filters.

HEPA filters require pre-filtering to remove large particulate matter, such as cyclones or venturi scrubbers to reduce large PM, and standard bag or cartridge filters to filter out particulate matter  $>PM_{2.5}$ .

For additional information on the description, application, advantages/disadvantages and limits/restrictions of the technique, please refer to the CWW BREF [21, European IPPC Bureau, 2003].

##### Achieved environmental benefits

- submicron particulate matter between  $PM_{0.12}$  and  $PM_{0.3}$  is abated along with hazardous air pollutants that are in particulate form, such as most heavy metals (except mercury).

##### Cross-media effects

- if it is not recycled back into production, the separated dust has to be disposed of accordingly. This type of dust might be classified as hazardous waste
- consumption of filter material
- consumption of energy.

##### Operational data

Operational data are presented in Table 4.9.

Parameter	Performance rate	Emission level	Remarks
	%	mg/Nm <sup>3</sup>	
PM		$>0.0001$ <sup>1</sup>	
$PM_{0.01}$	$>99.99$ <sup>1</sup>		
$PM_{0.1}$	$>99.9999$ <sup>1</sup>		
<sup>1</sup> From the CWW BREF			

Table 4.9: Operational data associated with the use of HEPA filters

##### Applicability

- generally applicable.

### **Economics**

- see the CWW BREF [21, European IPPC Bureau, 2003].

### **Reference literature**

CWW BREF [21, European IPPC Bureau, 2003].

#### 4.4.2.1.8 High Efficiency Air Filter (HEAF)

##### Description

An HEAF is a flat bed filter in which aerosols combine into droplets. Highly viscous droplets remain on the filter fabric and can eventually clog the filter. When a preset value of pressure difference is reached, the filter fabric has to be replaced by a new and clean filter, which can be exchanged during continuous operations, because the filter fabric is set on a roll. The treated waste gas leaves the treatment device via a mist filter, which has to separate the entrained layer of viscous droplets.

For additional information on the description, application, advantages/disadvantages and limits/restrictions of the technique, please refer to the CWW BREF [21, European IPPC Bureau, 2003].

##### Achieved environmental benefits

- Aerosols are removed, e.g. condensable VOCs.

##### Cross-media effects

- consumption of filter material
- consumption of energy.

##### Operational data

Operational data are presented in Table 4.10.

Parameter	Performance rate	Emission level	Remarks
	%	mg/Nm <sup>3</sup>	
Droplets	99 <sup>1</sup>		
Aerosols	99 <sup>1</sup>		
<sup>1</sup> From the CWW BREF			

**Table 4.10: Operational data associated with the use of HEAF filters**

##### Applicability

- generally applicable.

##### Economics

- see the CWW BREF [21, European IPPC Bureau, 2003].

##### Reference literature

CWW BREF [21, European IPPC Bureau, 2003].

### 4.4.2.1.9 Mist filter

#### Description

The most common mist filters (mist eliminators, demisters) are mesh pads. Mesh pad filters usually consist of woven or knitted metallic or synthetic material monofilament in either a random or specific configuration and are operated as deep bed filtration, which takes place over the entire depth of the filter. Solid dust particles remain in the filter until it is saturated and thus has to be cleaned by flushing. When the mist filter is used to collect droplets and/or aerosols, it is usually self-cleaning, drained by the liquid. They work by mechanical impingement and are velocity-dependent. Baffle angle separators are also commonly used as mist filters.

The basis for the filter dimension is the waste gas flowrate, the outlet contents and the filter load.

Mist filters are designed to remove specific particle sizes. Because of the plugging potential of high efficiency mesh pads, cleaning is necessary on a regular basis. If cleaning is neglected, the contaminants can solidify deep inside the pads and further pad flushing becomes ineffective.

For additional information on the description, application, advantages/disadvantages and limits/restrictions of the technique, please refer to the CWW BREF [21, European IPPC Bureau, 2003].

#### Achieved environmental benefits

- misty pollutants, such as droplets and aerosols are removed. When the filter material is cleaned in-situ, they are also applicable to solid particles soluble in liquids. Owing to clogging, they are less suitable for solid dusts and greasy vapours. They protect equipment from solid/liquid dust particles to prevent wear and friction on blower bearings and housings.

High efficiency mist filters can be used as primary devices. They are an increasingly viable option with regard to removal efficiency, water saving and economics in many processes that evolve mists such as sulphuric acid, nickel compounds, sodium hydroxide, nitric acid and chromium compounds.

#### Cross-media effects

- consumption of filter material
- consumption of washing liquid
- consumption of energy.

#### Operational data

Operational data are presented in Table 4.11.

Parameter	Performance rate	Emission level	Remarks
	%	mg/Nm <sup>3</sup>	
Droplets	99 <sup>1</sup>		
Aerosols	99 <sup>1</sup>		

<sup>1</sup> From the CWW BREF

Table 4.11: Operational data associated with the use of mist filters



### **Applicability**

- generally applicable.

### **Economics**

- see the CWW BREF [21, European IPPC Bureau, 2003].

### **Reference literature**

CWW BREF [21, European IPPC Bureau, 2003].

### 4.4.2.2 Waste gas treatment techniques to abate VOCs and inorganic compounds

#### 4.4.2.2.1 Membrane separation

##### Description

Membrane separation of gases takes into account the selective permeability of organic vapours when permeating through a membrane. Organic vapours have a considerably higher permeation rate than oxygen, nitrogen, hydrogen or carbon dioxide (10 to 100 times higher). The waste gas stream is compressed and passed over the membrane. The enriched permeate can be recovered by methods such as condensation (see Section 4.4.2.2.2) or adsorption (see Section 4.4.2.2.3), or it can be abated, e.g. by catalytic oxidation (see Section 4.4.2.2.8). The process is most appropriate to higher vapour concentrations. Additional treatment is, in most cases, needed to achieve concentration levels low enough to discharge.

Membrane separators are designed as modules, e.g. as capillary modules, manufactured as a polymer layer.

A membrane separation system consists of:

- the membrane modules
- a compressor
- a recovery unit (e.g. condenser, adsorber)
- vents and ducts
- possibly a second stage for further treatment.

To create the necessary pressure difference between the feed and permeate sides of the membrane (0.1 – 1 MPa), the system works either by means of excess pressure on the feed side and vacuum (about 0.2 kPa) on the permeate side or both.

During the rise of vapour concentration within the membrane unit, the concentration level can climb below to above the explosive limit and thus develop an explosive mixture. Safety is therefore a crucial issue and steps have to be taken to avoid these situations or to handle the risk.

For additional information on the description, application, advantages/disadvantages and limits/restrictions of the technique, please refer to the CWW BREF [21, European IPPC Bureau, 2003].

##### Achieved environmental benefits

- VOC recovery.

##### Cross-media effects

- consumption of energy.

## Operational data

Operational data are presented in Table 4.12.

Parameter	Performance rate (%)	Remarks
VOC	Up to 99.9 <sup>1</sup>	VOC recovery, upstream and downstream condensation unit
Hydrocarbon	90 – 99 <sup>1</sup>	Process for hydrocarbon recovery, upstream condensation unit
<sup>1</sup> From the CWW BREF		

**Table 4.12: Operational data associated with the use of membrane separation**

### Applicability

- generally applicable.

### Economics

- see the CWW BREF [21, European IPPC Bureau, 2003].

### Reference literature

CWW BREF [21, European IPPC Bureau, 2003].

#### 4.4.2.2.2 Condensation and cryogenic condensation

##### Description

Condensation is a technique that eliminates solvent vapours from a waste gas stream by reducing its temperature below its dew point.

There are different methods of condensation, depending on the operating temperature range:

- coolant condensation, condensation temperature down to about 25 °C
- refrigerant condensation, condensation temperature down to about 2 °C
- brine condensation, condensation temperature down to about -10 °C
- ammonia brine condensation, condensation temperature down to about -40 °C (one-stage) or -60 °C (two-stage)
- cryogenic condensation, condensation temperature down to about -120 °C, in practice often operated between -40 and -80 °C in the condensation device
- closed-cycle inert gas condensation.

Condensation is carried out by means of direct (i.e. contact between gas and cooling liquid) or indirect cooling (i.e. cooling via heat exchanger). Indirect condensation is preferred because direct condensation needs an additional separation stage. Recovery systems vary from simple, single condensers to more complex, multi-condenser systems designed to maximise energy and vapour recovery.

Cryogenic condensation can cope with all VOC and volatile inorganic pollutants, irrespective of their individual vapour pressures.

For additional information on the description, application, advantages/disadvantages and limits/restrictions of the technique, please refer to the CWW BREF [21, European IPPC Bureau, 2003].

##### Achieved environmental benefits

- volatile inorganic compounds and odorous substances are abated.

##### Cross-media effects

- generation of waste water (the quantity generated by the condensation facility is directly proportional to the amount of condensate, which in turn is directly proportional to the moisture content and the chosen cooling temperature)
- consumption of cooling medium (e.g. air, water, brine, ammonia-brine, nitrogen)
- consumption of energy.

##### Operational data

Operational data are presented in Table 4.13.

Parameter	Performance rate	Emission level	Remarks
	%	mg/Nm <sup>3</sup>	
Odour	60 – 90 <sup>1</sup>		
Amonia	20 – 60 <sup>1</sup>		

<sup>1</sup> From the CWW BREF

Table 4.13: Operational data associated with the use of condensation

### Applicability

- generally applicable.

### Economics

- see the CWW BREF [21, European IPPC Bureau, 2003].

### Reference literature

CWW BREF [21, European IPPC Bureau, 2003].

#### 4.4.2.2.3 Adsorption

##### Description

Adsorption is a heterogeneous reaction in which gas molecules are retained on a solid surface (adsorbent) that prefers specific compounds to others and thus removes them from effluent streams. When the surface has adsorbed nearly as much as it can, the adsorbed content is desorbed as part of regenerating the adsorbent. When desorbed, the contaminants are usually at a higher concentration and can either be recovered or abated (destroyed).

Major types of adsorption systems are:

- fixed-bed adsorption
- fluidised-bed adsorption
- continuous moving-bed adsorption
- Pressure-Swing Adsorption (PSA).

Typical adsorbents are, e.g.

- Granular Activated Carbon (GAC), the most common adsorbent with a wide efficiency range and not restricted to polar or non-polar compounds; GAC can be impregnated with, e.g. oxidants such as potassium permanganate or with sulphur compounds (improving retention of heavy metals)
- Zeolites (whose properties depend on its manufacture, working either as mere molecular sieves, selective ion exchanger or hydrophobic VOC adsorber)
- macroporous polymer particles, which are used as granules or beads, not being highly selective with respect to VOC
- silica gel
- sodium-aluminium silicates.

Besides the continuous and simultaneous regeneration methods, there are several methods to regenerate the adsorbent of fixed-bed adsorbers:

- thermal-swing regeneration
- vacuum regeneration
- PSA.

For additional information on the description, application, advantages/disadvantages and limits/restrictions of the technique, please refer to the CWW BREF [21, European IPPC Bureau, 2003].

### Achieved environmental benefits

- VOC recovery
- abatement of pollutants (hazardous substances from production or treatment facilities – e.g. WWTP – such as VOC, odours, trace gases etc.) that cannot be recirculated or otherwise used, possibly with GAC as the adsorbent, are not regenerated but incinerated.

The application as abatement technology is not recommended for waste gases with very high VOC concentrations, because the consequent regeneration requirements would adversely affect profitability. There are normally more suitable techniques.

### Cross-media effects

- consumption of adsorbents
- consumption of energy
- consumption of cooling water.

### Operational data

Operational data are presented in Table 4.14.

Parameter	Performance rate	Emission level	Remarks
	%	mg/Nm <sup>3</sup>	
VOC	80 – 95 <sup>1</sup>		GAC
Odour	80 – 95 <sup>1</sup>		GAC, zeolite
Mercury		<0.01 – 0.05 <sup>1</sup>	GAC
Hydrogen sulphide	80 – 95 <sup>1</sup>		GAC
<sup>1</sup> From the CWW BREF			

**Table 4.14: Operational data associated with the use of adsorption**

### Applicability

- see the CWW BREF [21, European IPPC Bureau, 2003].

### Economics

- see the CWW BREF [21, European IPPC Bureau, 2003].

### Reference literature

CWW BREF [21, European IPPC Bureau, 2003].

#### 4.4.2.2.4 Wet gas scrubber

##### Description

Wet scrubbing (or absorption) is a mass transfer between a soluble gas and a solvent – often water – in contact with each other. Physical scrubbing is preferred for chemical recovery, whereas chemical scrubbing is restricted to removing and abating gaseous compounds. Physico-chemical scrubbing takes an intermediate position. The component is dissolved in the absorbing liquid and involved in a reversible chemical reaction, which enables the recovery of the gaseous component.

Depending on the pollutants to be removed, several aqueous scrubbing liquids are used:

- water, to remove solvents and gases such as hydrogen halides or ammonia, with the main aim to recover and re-use these contaminants
- alkaline solutions, to remove acid components such as hydrogen halides, sulphur dioxide, phenols, chlorine; also used for second-stage scrubbing to remove residual hydrogen halides after first-stage aqueous absorption; biogas desulphurisation
- alkaline-oxidation solutions, i.e. alkaline solutions with sodium hypochlorite, chlorine dioxide, ozone or hydrogen peroxide
- sodium hydrogensulphite solutions, to remove odour (e.g. aldehydes)
- Na<sub>2</sub>S<sub>4</sub> solutions to remove mercury from waste gas
- acidic solutions, to remove ammonia.

Various types of scrubbers are operated, e.g.

- fibrous packing scrubbers
- moving bed scrubbers
- packed bed scrubbers
- impingement plate scrubbers
- spray towers.

For additional information on the description, application, advantages/disadvantages and limits/restrictions of the technique, please refer to the CWW BREF [21, European IPPC Bureau, 2003].

##### Achieved environmental benefits

- removal of gaseous pollutants, such as hydrogen halides, SO<sub>2</sub>, ammonia, hydrogen sulphide
- removal of SO<sub>2</sub> or hydrogen halides
- removal of dust with certain types of scrubbers (see Section 4.4.2.1.3).

## Operational data

Operational data are presented in Table 4.15.

Parameter	Performance rate	Emission level	Remarks
	%	mg/Nm <sup>3</sup>	
Hydrogen fluoride	>99 <sup>1</sup>	<50 <sup>1</sup>	Water
		<1 <sup>1</sup>	Alkaline
Hydrogen chloride	>99 <sup>1</sup>	<50 <sup>1</sup>	Water
		<10 <sup>1</sup>	Alkaline
Chromic acid		<0.1 – 1 <sup>1</sup>	Water
Ammonia	>99.9 <sup>1</sup>	<1 <sup>1</sup>	Acid
Sulphur dioxide	80 – 99 <sup>1</sup>	<40 <sup>1</sup>	Alkaline
Hydrogen sulphide	90 – 95 <sup>1</sup>		Alkaline
Inorganic compounds	95 – 99 <sup>1</sup>		

<sup>1</sup> From the CWW BREF

**Table 4.15: Operational data associated with the use of wet gas scrubbers**

### Applicability

- generally applicable.

### Economics

- see the CWW BREF [21, European IPPC Bureau, 2003].

### Reference literature

CWW BREF [21, European IPPC Bureau, 2003].



#### 4.4.2.2.5 Removal of HCN and NH<sub>3</sub> from waste gases

##### Description

Hydrogen cyanide (HCN) and ammonia (NH<sub>3</sub>) are removed from waste gases using one alkaline scrubber with NaOH solution and one acidic scrubber with H<sub>2</sub>SO<sub>4</sub> solution. For each scrubber, the solution is circulated between a buffer vessel and the scrubber. The solution in each scrubber is sampled regularly and exchanged if the content of free OH<sup>-</sup> is too low for the absorption of HCN from the waste gas stream or if the content of free H<sub>2</sub>SO<sub>4</sub> is too low for the absorption of ammonia. When possible, the spent solution from the alkaline scrubber is recycled back into the process to substitute raw materials. The ammonium sulphate solution formed in the acidic scrubber can be recycled off-site (e.g. in plants producing fertilisers).

For safety purposes, the secondary containment of the acidic scrubber is strictly separated from the secondary containment of the alkali scrubber and the rest of the production building. This is to avoid, in the case of an accident, acids coming into contact with solutions containing cyanide, a situation which would lead to the emission of HCN into the environment, primarily to the working areas.

A schematic overview of this technique is shown in Figure 4.3.

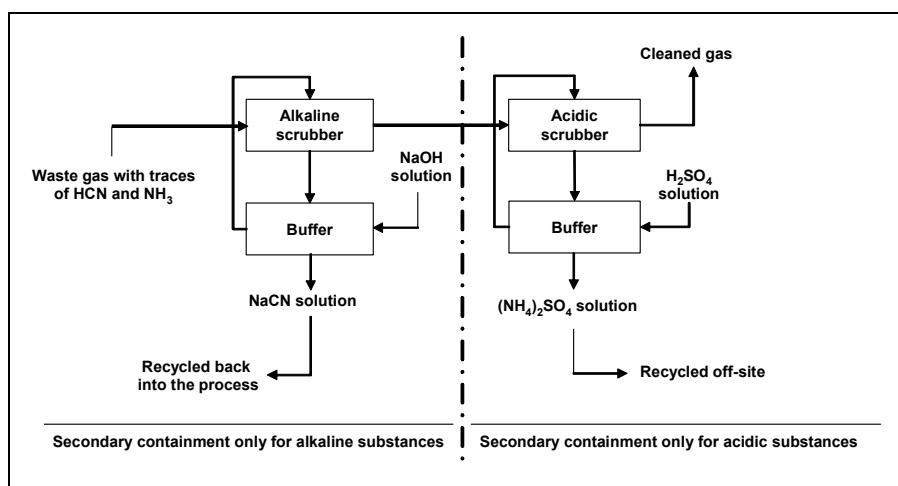

Figure 4.3: Removal of HCN and NH<sub>3</sub> from waste gases

##### Achieved environmental benefits

- removal of HCN and NH<sub>3</sub> from waste gases
- no waste water from the alkaline scrubber (re-use of the alkaline scrubber solution into the process to substitute raw materials)
- strict separation of acidic and alkaline containment reduces the potential for hazardous emissions in the case of an accident.

The achieved emission levels for the removal of HCN and NH<sub>3</sub> from waste gases are shown in Table 4.16.

	Concentration	Mass-flow	Reference
HCN	1 mg/m <sup>3</sup>	3 g/h	CyPlus, Germany
NH <sub>3</sub>	1.2 mg/m <sup>3</sup>	3 g/h	

Table 4.16: Achieved emission levels for the removal of HCN and NH<sub>3</sub> from waste gases

**Cross-media effects**

- energy consumption.

**Operational data**

Operational data are presented in Table 4.17.

		<b>Flow and concentrations at the inlet of the treatment system</b>	<b>Reference</b>
<b>Treatment capacity</b>	Gas stream	3400 m <sup>3</sup> /h 50 mg/m <sup>3</sup> HCN 250 mg/m <sup>3</sup> NH <sub>3</sub>	CyPlus, Germany
<b>Overall efficiency</b>		99.2 %	

**Table 4.17: Operational data for the removal of HCN and NH<sub>3</sub> from waste gases**

**Applicability**

- generally applicable.

**Economics**

- low operation costs
- cost reduction for raw materials.

**Driving force for implementation**

- removal of toxic compounds from waste gases.

**Example plants**

- CyPlus, Germany.

#### 4.4.2.2.6 Twin-bed oxidiser systems

##### Description

A twin-bed RTO (Regenerative Thermal Oxidiser) system provides a way for solvent-laden gas to be converted into CO<sub>2</sub> and H<sub>2</sub>O vapour.

The oxidiser consists of a reinforced, insulated twin-bed chamber filled with ceramic heat exchanger media. The gas flow is automatically controlled by a zero leakage poppet valve mechanism that changes the direction of the gas flow at regular intervals via an integral Programmable Logic Control (PLC) system with remote modem-based telemetry diagnostics. Due to the abundant oxygen content of the process gas, complete combustion readily occurs when the ignition point is reached in the oxidiser (typically 870 to 927 °C for RTO and 316 to 427 °C for RCO – Regenerative Catalytic Oxidation). Process hydrocarbons are converted to carbon dioxide and water vapour. With a sufficient concentration of solvents in the incoming process gas (400+ PPM), the exotherm of the solvent heat release will be enough so that the destruction of VOCs will be self-sustaining and flameless (no NO<sub>x</sub>), with no supplemental auxiliary heat energy required from the burner. The high degree of heat recovery (typically 95 % primary heat recovery) achieved is the result of regenerative heat transfer. The VOC-laden process air enters a porous bed filled with high temperature ceramic heat transfer media. The air is preheated by the first heat recovery bed, passes through a central combustion chamber where the hydrocarbons are oxidised to carbon dioxide and water vapour, and then exits a second heat recovery bed where heat is transferred from the hot air back into the bed. In order to avoid an uneven temperature distribution throughout the oxidiser, the gas flow direction is changed at regular intervals by the automatic poppet valve flow switching mechanism and PLC controls to maintain an even temperature profile between the two beds.

##### Achieved environmental benefits

- >99 % VOC abatement
- >95 % heat recovery. NO<sub>x</sub> level is negligible.

##### Cross-media effects

- generation of CO<sub>2</sub> (and H<sub>2</sub>O vapour).

##### Operational data

The VOC-laden process air enters a porous bed filled with high temperature ceramic heat transfer media. The air is preheated by the first heat recovery bed, passes through a central combustion chamber where the hydrocarbons are oxidised to carbon dioxide and water vapour, and then exits a second heat recovery bed where heat is transferred from the hot air back into the bed. In order to avoid an uneven temperature distribution throughout the oxidiser, the gas flow direction is changed at regular intervals by the automatic poppet valve flow switching mechanism and PLC controls to maintain an even temperature profile between the two beds.

##### Applicability

For point sources of 1680 to 136200 m<sup>3</sup>/h, mobile units also exist for temporary usage.

## 4.4.2.2.7 Incineration of exhaust gases containing Volatile Organic Compounds (VOCs)

**Description**

Raw material used may contain small amounts of volatile organic compounds (e.g. benzene) which can be found in several gas streams of the production process. The gas streams which contain VOCs are identified and separated from the others. The VOCs are incinerated in an air heater which is run by natural gas. The energy from the incineration is recovered. The circulation drying air is heated with this energy. Figure 4.4 shows a scheme of this technique.

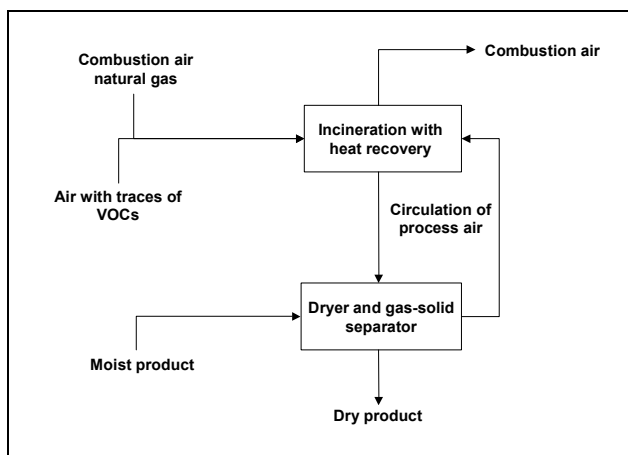

**Figure 4.4: Incineration of process air containing Volatile Organic Compounds (VOCs)**

Because there is a risk of dioxin/furan (PCDD/F) formation when chlorinated compounds are incinerated, the following operating conditions are generally considered appropriate for the incineration of halogenated organic substances (these conditions are indicated in several EU regulations on incineration, e.g. Directive 2000/76/EC on the incineration of waste):

- temperature >1100 °C (850 °C when incinerating waste with less than 1 % of halogenated organic substances)
- residence time >2 s
- oxygen content >3 %.

In addition, conditions that favour formation of dioxins/furans immediately following combustion are to be prevented. This is achieved by a ‘fast-quench’ of post-combustion gases by cooling them very quickly from high temperatures to below the temperature-window of dioxins/furans reformation.

These measures are designed to keep PCDD/F emissions below 0.1 ng TEQ/Nm<sup>3</sup>.

In the case of the combustion of halogenated VOC substances, an HCl scrubber is necessary.

**Achieved environmental benefits**

- removal of VOCs (e.g. benzene) from waste gases
- saving of natural gas to run the air heater.

The achieved emission levels are given in Table 4.18.

	VOC concentration	Mass-flow	Reference
Waste gas	<0.6 mg/m <sup>3</sup>	0.4 g/h	CyPlus, Germany

**Table 4.18: Achieved emission levels after incineration of VOCs**

#### Cross-media effects

- none.

#### Operational data

Operational data are presented in Table 4.19.

		Flow and concentration at the inlet of the treatment system	Reference
Treatment capacity	Gas stream	2500 m <sup>3</sup> /h Variable benzene concentration	CyPlus, Germany
Overall efficiency		99.9 %	

**Table 4.19: Operational data for the incineration of VOCs**

#### Applicability

- generally applicable.

#### Economics

- reduction of energy costs
- comparably low investment costs.

#### Driving force for implementation

- removal of toxic compounds from waste gases.

#### Example plants

- CyPlus plant, Germany.

#### 4.4.2.2.8 Catalytic oxidation

##### Description

Catalytic oxidisers operate in a very similar way to thermal oxidisers, with the main difference that the gas, after passing through the flame area, passes through a catalyst bed. The catalyst has the effect of increasing the oxidation reaction rate, enabling conversion at lower reaction temperatures than in thermal oxidation units. Catalysts, therefore, also allow smaller oxidisers to be used.

The waste gas is heated by auxiliary burners to approximately 300 – 500 °C before entering the catalyst bed. The maximum design exhaust temperature of the catalyst is typically 500 – 700 °C.

The method of contacting the gas stream with the catalyst serves to distinguish catalytic oxidation systems. Both fixed-bed and fluidised-bed systems are used.

Catalysts for VOC oxidation are typically either:

- precious metals, such as platinum, palladium and rhodium, supported on ceramic or
- metals, or base metals, supported on ceramic pellets or
- single or mixed metal oxides, often supported by a mechanically strong carrier, such as oxides of copper, chromium, manganese, nickel, cobalt etc.

For additional information on the description, application, advantages/disadvantages and limits/restrictions of the technique, please refer to the CWW BREF [21, European IPPC Bureau, 2003].

##### Achieved environmental benefits

- reduction of VOC emissions
- reduction of CO and PM emissions (the latter require special operational devices).

##### Cross-media effects

- consumption of energy.

##### Operational data

Operational data are presented in Table 4.20.

Parameter	Performance rate (%)	Emission level (mg/l)
VOC	90 – 99 <sup>1</sup>	<1 – 20 <sup>1</sup>
CO	>98 <sup>1</sup>	
PM <sub>10</sub>	50 – 99.9 <sup>1</sup>	
<sup>1</sup> From the CWW BREF		

**Table 4.20: Operational data associated with the use of catalytic oxidation**

## Applicability

Catalytic oxidation is most suited to systems with lower exhaust volumes, when there is little variation in the type and concentration of VOC, and where catalyst poisons or other fouling contaminants are not present.

## Economics

- see the CWW BREF [21, European IPPC Bureau, 2003].

## Reference literature

CWW BREF [21, European IPPC Bureau, 2003].

### 4.4.2.3 Waste gas treatment techniques to abate gaseous pollutants in combustion exhaust gases

#### 4.4.2.3.1 Sorbent injection for abating acid gases and fluorides

##### Description

The reaction principle of Flue-Gas Desulphurisation (FGD) sorbent injection is the introduction of reactive material to, and its dispersion in, the waste gas stream. This material reacts with SO<sub>x</sub> species to form a solid, which has to be removed afterwards from the waste gas stream (e.g. using an ESP or a bag filter). The most used sorbents are:

- lime
- sodium hydrogencarbonate (sodium bicarbonate)
- sodium carbonate (soda).

The choice of the sorbent depends on its availability. It is, in most cases, a naturally occurring material, such as limestone, dolomite or hydrated compounds derived from these raw materials.

These sorbents are also effective in removing other acid gases, particularly hydrogen chloride and fluoride. If these acid gases are intended to be recovered, the waste gas needs to be pretreated (water scrubbing, see Section 4.4.2.2.4).

There are three types of sorbent injection techniques:

- dry sorbent injection
- semi-dry (or semi-wet) injection
- wet injection of lime milk.

**With dry sorbent injection**, the fine powdered sorbent is either injected into the flue-gas stream or added to a reaction tower, the latter being the more efficient method. When the sorbent is injected into the gas stream, this can be done at various positions according to the temperature and conditions at which it is most reactive.

**With semi-dry sorbent injection**, the sorbent is added as a suspension or solution (droplets) in a reaction chamber in such a way that the liquid is continuously evaporating during the reaction. The result is a dry product, collected at the base of the chamber or in a particulate abatement device.

**With wet sorbent injection**, SO<sub>2</sub> is removed from the flue-gas in the FGD absorber by direct contact with an aqueous suspension of finely ground limestone (lime milk), after having left the particulate control system and passed through a heat exchanger. The scrubbed flue-gas passes through a mist eliminator and is released to the air by a stack or cooling tower. The reaction products are withdrawn from the absorber and sent for dewatering and further processing.

For additional information on the description, application, advantages/disadvantages and limits/restrictions of the technique, please refer to the CWW BREF [21, European IPPC Bureau, 2003].

### **Achieved environmental benefits**

- abatement of acid gases (e.g. SO<sub>2</sub>, SO<sub>3</sub>, HCl, HF) in the waste gas.

### **Cross-media effects**

- in the case of dry and semi-dry sorption, the residue is a mixture of the original sorbent and the reaction products which, if it cannot be recovered or recycled, has to be disposed of
- consumption of sorbent
- consumption of energy for dry and semi-dry sorbent injection
- consumption of water for semi-dry and wet sorbent injection.

### **Operational data**

- see the CWW BREF [21, European IPPC Bureau, 2003].

### **Applicability**

- generally applicable.

### **Economics**

- see the CWW BREF [21, European IPPC Bureau, 2003].

### **Example plants**

- Colorobbia, Italy (see also Section 6.1.4.3).

### **Reference literature**

CWW BREF [21, European IPPC Bureau, 2003].



#### 4.4.2.3.2 Selective reduction of NO<sub>x</sub> (SNCR and SCR)

##### Description

Selective reduction of NO<sub>x</sub> involves the injection of NH<sub>2</sub>-X compounds (where X = H, CN or CONH<sub>2</sub>) into the flue-gas stream, reducing nitrogen oxides to nitrogen and water. The most common reduction agent is a 25 % aqueous solution of ammonia or pure ammonia. Other reaction agents are urea solutions, nitrolime or cyanamide.

There are different variants of selective NO<sub>x</sub> reduction:

- selective non-catalytic reduction (SNCR)
- selective catalytic reduction (SCR).

**With SNCR**, the reduction agent is injected in the area where the exhaust gases have reached a temperature of between 930 and 980 °C, whereas urea is injected in an area where the gas temperature is between 950 and 1050 °C. The injection occurs after combustion and before other treatment. Temperature, NH<sub>3</sub>/NO<sub>x</sub> molar ratio and residence time are the main parameters for optimum reduction efficiency. Temperatures below the level mentioned above cause unconverted ammonia to be emitted (ammonia slip); temperatures significantly above the level oxidise ammonia to NO<sub>x</sub>. SNCR is operated with a NH<sub>3</sub>/NO<sub>x</sub> molar ratio range of 0.5 – 0.9. At higher levels (>1.2), ammonia slip can also occur, generating aerosols of ammonium chloride and sulphate, which pass through the filter and cause visible white plumes above the exhaust gas stack. The residence time and mixing quality are decisive for the reaction efficiency. Too short a residence time will cause ammonia slip.

**With SCR**, the exhaust gas stream and the injected agent are passed over a catalyst, with operation temperatures of between 200 and 500 °C, dependent on the catalyst. The optimum mixing, i.e. NH<sub>3</sub>/NO<sub>x</sub> molar ratio, over the catalyst is vital. The molar ratio level is usually kept below 1.1 to limit the potential for ammonia slip.

The considerably lower temperatures compared to SNCR make possible the installation of SCR downstream of other treatment devices such as dust abatement and FGD. With this 'cold' Denox process, a mixture of air (to control optimum oxygen content) and ammonia is added after FGD. The desulphurised flue-gas stream needs to be reheated at the necessary reaction temperature. The advantage of this procedure is that, because there is no adsorption to dust, there is no potential for ammonia slip.

For additional information on the description, application, advantages/disadvantages and limits/restrictions of the technique, please refer to the CWW BREF [21, European IPPC Bureau, 2003].

##### Achieved environmental benefits

- abate nitrogen oxides from processes such as chemical production, combustion or process furnaces.

##### Cross-media effects

- consumption of ammonia
- consumption of steam to evaporate ammonia
- consumption of energy.

### Operational data

- see the CWW BREF [21, European IPPC Bureau, 2003].

### Applicability

- generally applicable.

### Economics

- see CWW BREF [21, European IPPC Bureau, 2003].

### Reference literature

CWW BREF [21, European IPPC Bureau, 2003].

#### 4.4.2.3.3 Wet SO<sub>2</sub> abatement techniques

##### Description

Sulphur dioxide emissions are generated if sulphur is added as a reduction agent to the reaction process. There are several off-gas treatment methods for the elimination of SO<sub>2</sub>:

- washing with caustic soda.

When washing with caustic soda, SO<sub>2</sub> is converted into sodium sulphite. In some cases, hydrogen peroxide can be added to the effluent, in order to accelerate the generation of sodium sulphate.

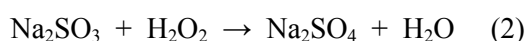

- washing with calcium carbonate – Flue-Gas Desulphurisation (FGD).

When washing with calcium carbonate, SO<sub>2</sub> is converted into calcium sulphite or calcium sulphate slurry.



Reaction (4) can only take place at elevated temperature (>900 °C):

##### Achieved environmental benefits

- SO<sub>2</sub> abatement.

The achieved emission levels are given in Table 4.21.

	Concentration	Mass-flow	Reference
Waste gas	100 – 200 mg/Nm <sup>3</sup>		

**Table 4.21: Achieved emission levels after SO<sub>2</sub> abatement**

### 4.4.3 Combined waste water and waste gas treatment techniques

#### 4.4.3.1 Scrubbing and recycling of cyanides from waste gases and waste waters using hydrogen peroxide (H<sub>2</sub>O<sub>2</sub>) as the oxidising agent

##### Description

Cyanides (in the form of HCN gas) are removed from waste gases using a scrubber with NaOH solution (or KOH solution). The solution is circulated between a buffer vessel and the scrubber. The solution is sampled regularly and exchanged if the content of free OH<sup>-</sup> is too low for the absorption of HCN from the gas stream. The spent solution loaded with cyanides is then reconditioned (reconditioning consists basically of mixing the spent solution in order to achieve a fairly constant/homogeneous CN concentration) with other CN rich waste water streams to substitute raw materials in the production process (in the case where cyanide compounds are manufactured). A CN<sup>-</sup> low waste water stream exits the reconditioning unit. The remaining cyanide is destroyed together with CN<sup>-</sup> low waste water streams using pH adjustment and oxidative destruction with hydrogen peroxide (H<sub>2</sub>O<sub>2</sub>). A schematic overview of this technique is shown in Figure 4.5.

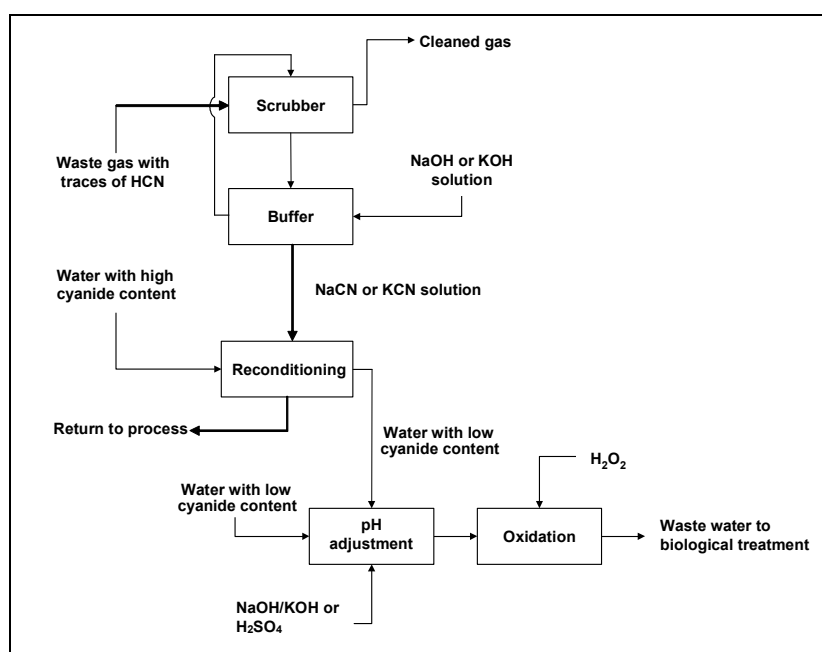
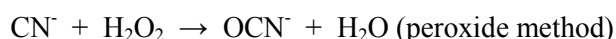
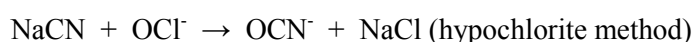

Figure 4.5: Scrubbing and recycling of cyanides from waste gases and waste waters

Using H<sub>2</sub>O<sub>2</sub> based technology (as opposed to hypochlorite, for example) does not generate salts and AOX by-products.



##### Achieved environmental benefits

- removal of HCN/CN<sup>-</sup> from waste gases and waste waters
- re-use of waste water streams as raw materials
- no AOX in waste water
- no contaminated waste.

Achieved emission levels for discharge to a biological WWTP are given in Table 4.22.

	Concentration	Mass-flow	Reference
Waste gas	1 mg HCN/m <sup>3</sup>	3 g HCN/h	CyPlus, Germany
Waste water	1.1 mg CN <sup>-</sup> /l	2.3 g CN <sup>-</sup> /h	

**Table 4.22: Achieved emission levels after scrubbing and recycling of cyanides**

#### Cross-media effects

- energy consumption.

#### Operational data

Operational data are presented in Table 4.23.

		Concentration	Reference
Treatment capacity	Gas stream	3400 m <sup>3</sup> /h 50 mg HCN/m <sup>3</sup>	CyPlus, Germany
	Waste water with high CN <sup>-</sup> concentration	1 m <sup>3</sup> /h 5 % CN <sup>-</sup>	
	Waste water with low CN <sup>-</sup> concentration	15 m <sup>3</sup> /h 700 mg HCN/m <sup>3</sup>	
Overall efficiency	99.9 %		

**Table 4.23: Operational data for the scrubbing and recycling of cyanides**

#### Applicability

- generally applicable.

#### Economics

Cost reduction for waste water treatment due to the absence of AOX load. The technique is in practice at some installations.

#### Driving force for implementation

- removal of toxic compounds from waste gases and waste waters.

#### Example plants

- CyPlus plant, Germany.

## 4.4.4 Treatment techniques of liquid (non-aqueous) and solid residues

### 4.4.4.1 Thickening and dewatering

#### Description

Sludge thickening and sludge dewatering are operations to increase the solid content of sludge and remove a part of the water fraction. Their benefit shows a substantial (about five fold or more) decrease in volume to facilitate subsequent treatment operations as well as decrease the necessary size and capacity of treatment equipment. Both treatments differ only in the extent of water removal.

Common techniques are:

- gravity thickening, or sedimentation, using a settling tank
- centrifugal thickening (also as a dewatering technique), ideal for high solid capture, operated either as solid bowl centrifuge or imperforate basket centrifuge
- flotation thickening
- gravity belt thickening, using a gravity belt moving over driven rollers, the conditioned sludge added at one end into a feed/distribution box, the sludge ridged and furrowed by a series of plough blades, allowing the released water to pass through the belt
- rotary drum thickening, the unit consisting of a sludge conditioning system with polymer feed and rotating cylindrical screens where the polymer and thin sludge are mixed to flocculate and then separated from the water in the rotating screen drums
- belt filter press dewatering, where the conditioned sludge is introduced to a gravity drainage section to thicken and separate from the water because of gravity, this operation assisted by vacuum which simultaneously enhances drainage and reduces odour; then pressure applied in a low pressure sector, where the sludge is squeezed between opposing porous belts to release additional water
- filter press dewatering, where the solid/liquid separation takes place at high pressure, the sludge forced through a series of filter cloths to retain the particulates as filter cake and the filtrate recycled to the waste water treatment plant.

For additional information on the description, application, advantages/disadvantages and limits/restrictions of the technique, please refer to the CWW BREF [21, European IPPC Bureau, 2003].

#### Achieved environmental benefits

- the volume of residues to facilitate subsequent treatment operations are reduced.

#### Cross-media effects

- consumption of energy
- consumption of chemicals (e.g. flocculants, polymers)
- consumption of washing water
- aqueous effluents need to be treated in the WWTP
- noise and odour may be issues.

#### Operational data

Achievable emission levels/performance rates are indicated in the CWW BREF [21, European IPPC Bureau, 2003].

### **Applicability**

- generally applicable.

### **Economics**

- economic information can be found in the CWW BREF [21, European IPPC Bureau, 2003].

### **Reference literature**

CWW BREF [21, European IPPC Bureau, 2003].

#### 4.4.4.2 Stabilisation and conditioning

##### Description

Stabilisation of sewage sludge is a pretreatment operation prior to thickening and/or dewatering.

Stabilisation techniques are:

- chemical stabilisation, chiefly using lime either as pretreatment, i.e. before dewatering, or as post-treatment, i.e. after dewatering, to raise the pH to >12 and thus kill pathogens
- thermal stabilisation, by heating the sludge in a pressure vessel at temperatures of up to 260 °C and pressures of up to 2.8 MPa for approximately 30 minutes. This is also used as a conditioning technique
- aerobic digestion, working in a tank – similar to the aerobic activated-sludge process for waste water treatment – with air or pure oxygen and adequate stirring, resulting in a 75 to 80 % reduction of the activated sludge content; the technique is an attractive option when separate sludge digestion is considered
- anaerobic digestion, working in a tank without air either in the mesophilic (30 to 38 °C) or the thermophilic (49 to 57 °C) range and producing a combustible gas mixture (65 to 70 % methane, 25 to 30 % carbon dioxide, small amounts of nitrogen, hydrogen, hydrogen sulphide, etc.) with a low heating value of about 22 MJ/Nm<sup>3</sup>
- dual sludge stabilisation, combining an upstream aerobic thermophilic and a downstream anaerobic mesophilic digestion.

The purpose of sludge conditioning is to improve the conditions for thickening and/or dewatering. Conditioning techniques are:

- chemical conditioning using, e.g. ferric chloride, lime, alum and organic polymers (coagulants and flocculants)
- thermal conditioning, by heating the sludge in a pressure vessel.

For additional information on the application, advantages/disadvantages and limits/restrictions of the technique, please refer to the CWW BREF [21, European IPPC Bureau, 2003].

##### Achieved environmental benefits

- reduce or eliminate the amount of odorous constituents
- reduce the quantity of biodegradable sludge solids
- improve dewatering
- reduce pathogens
- reduce or eliminate the potential for putrefaction.

##### Cross-media effects

- consumption of chemicals (e.g. lime, polymers)
- consumption of energy.

##### Applicability

Generally applicable.

##### Reference literature

CWW BREF [21, European IPPC Bureau, 2003].

### 4.4.4.3 Thermal sludge reduction

Thermal sludge reduction is not generally performed at a SIC installation. Generally, only larger sites operate this type of sludge treatment, others commission their sludge to external discharge. The reasons are that skilled personnel are needed, the capital and maintenance costs are considerable and the benefits from generated heat are normally relevant only to larger plants or where equipment is already available [21, European IPPC Bureau, 2003].

## 4.5 Infrastructure

### 4.5.1 Cleaning-In-Place (CIP) systems of equipment contaminated with solid hazardous compounds

#### Description

During production, solid hazardous compounds (e.g. solid cyanide) can build up in pipelines, machines and vessels and can ultimately provoke equipment malfunction or blockage. A Cleaning-In-Place (CIP) system allows easy cleaning and rinsing of equipment in a closed system. With such a system, workers are not exposed to harmful emissions. The rinsing water containing the hazardous material is collected in a closed piping system and stored in tanks. The rinsing water is recycled back into production when possible to reduce the use of fresh water as a raw material. When the solid hazardous compounds are the products manufactured in the installation, off-specification products can (if they are soluble) be dissolved in the rinsing water collecting tanks and recycled back into the process in order to reduce the amount of hazardous waste produced. A schematic overview of this technique is shown in Figure 4.6.

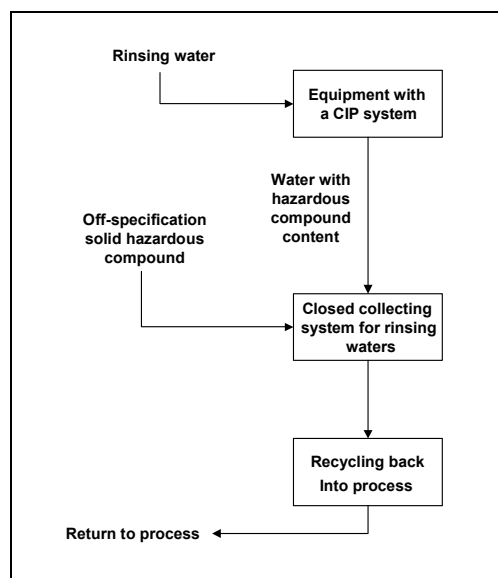

Figure 4.6: A Cleaning-In-Place-system (CIP) of equipment contaminated with solid hazardous compounds

#### Achieved environmental benefits

- no solid wastes containing hazardous compounds
- recycling of waste water containing hazardous compounds within the process
- reduction of raw material consumption (i.e. fresh water)
- protection of the workers
- reduction of emissions to the environment and to the working areas.



As an example, the emission levels achieved at a plant producing cyanides in Germany are given in Table 4.24.

	Concentration	Mass-flow	Reference
Solid waste		0 kg/yr	CyPlus, Germany

**Table 4.24: Achieved emission levels associated with the CIP of equipment contaminated with cyanides**

#### Cross-media effects

- energy consumption.

#### Operational data

As an example, the operational data for a plant producing cyanides in Germany are given in Table 4.25.

		Flow and concentration at the inlet of the treatment system	Reference
Treatment capacity	Rinsing water	15 m <sup>3</sup> /h variable cyanide concentration	CyPlus, Germany
Overall efficiency		99 % <sup>1</sup>	
<sup>1</sup> The remaining 1 % of the cyanides either desagregates (hydrolysis) to by-products or ends up in the cyanide detoxification unit			

**Table 4.25: Operational data for the cleaning of equipment contaminated with cyanides**

#### Applicability

- generally applicable.

#### Economics

- cost reduction for waste water treatment
- cost reduction for raw materials.

#### Driving force for implementation

- reduction of emissions to the environment and the working areas.

#### Example plants

- CyPlus, Germany.

## 4.5.2 Use of a computerised control system to operate the plant

### Description

The operation of a SIC production plant requires frequent monitoring of numerous parameters, and adjustments to the process conditions, particularly to ensure safety and environmental control. A computerised control system can help monitor hundreds of process parameters and automatically make the required adjustments to ensure an efficient, safe and environmentally sound operation. Using a computerised control system, automatic interlocks can be implemented to prevent the overfilling of tanks or to minimise the generation of waste water, for example. Also, it can precisely monitor the conditions to ensure the highest product yield in the reactor.

### Achieved environmental benefits

- reduction of emissions
- reduction of contaminated waste water
- health and safety of the workers
- reduction of raw material consumption
- higher product yield.

### Cross-media effects

- none.

### Applicability

This technique may not be applicable in certain cases. For example, the production of SIC explosives relies on manual operation because detonation risks are frequently detected by visual inspection, by long expertise and by highly qualified personnel.

### Economics

- slight reduction in production costs (e.g. energy, waste treatment).

### Driving force for implementation

- more efficient control of process conditions
- reduction of emissions.

### Example plants

- CyPlus, Germany.

## 4.6 Energy

### 4.6.1 Pinch methodology

#### Description

Pinch is a methodology that is used in the chemical industry in order to optimise the production process vis-à-vis the utilisation of energy. The methodology consists of looking at the production process (and even at several production processes from different plants) in terms of hot and cold streams and building hot and cold composite curves on a temperature-enthalpy diagram which represents the total heating and cooling requirements of the process. The point at which the hot and cold composite curves come closest to touching is known as the pinch which indicates the maximum possible amount of process-to-process heat exchange.

For a further description of the technique, please refer to the OFC BREF [18, European IPPC Bureau, 2004].

#### Achieved environmental benefits

- optimisation of the energy balance on a production site.

#### Cross-media effects

- none.

#### Operational data

The key to applying pinch methodology in non-continuous processes is the data extraction. There are no shortcuts; detailed measurements and timings of all the process streams are essential if cost saving (= energy saving) opportunities are to be found.

#### Applicability

The application of pinch often results in installing plant equipment in different locations than to the location that would result from the logic of product flow. Design and layout may result in additional equipment (e.g. pumps, compressors, heat exchangers) and piping sections which would then incur extra costs. It should also be noted also that the complexity of the control system may increase dramatically which can increase, e.g. the risks of incidents. The compatibility of substances (fluids) exchanging heat should be taken into account in the design of the heat exchange equipment. If substances (fluids) are very incompatible (e.g. risk of explosion if the two substances come into contact – due to corrosion problems) then alternative energy saving techniques, e.g. energy exchange via an intermediate fluid, may need to be evaluated instead for safety reasons.

Pinch methodology can better be used at the concept stage for new and large installations. Pinch methodology is usually not applicable for existing installations. There might be difficulties to apply pinch at installations operating in a non-continuous mode (which is the case for the vast majority of installations producing inorganic pigments for example).

## Economics

The additional capital cost compared to a ‘classical’ plant should be balanced by sufficient energy savings.

## Reference literature

OFC BREF [18, European IPPC Bureau, 2004]

## 4.7 Cross-boundary techniques

### 4.7.1 Ground protection

#### Description

Facilities where substances (usually liquids) that represent a contamination potential to the ground, surface water and groundwater are built, operated and maintained in such a way that no spills occur. They are sealed, stable and sufficiently resistant against possible mechanical, thermal or chemical stress. Leakages are quickly and reliably recognised.

Leaking substances are safely retained and treated/disposed of. This is realised by applying an impervious and stable retention area according to the amount of substance that could be spilled before other measures take effect. Additionally, double walled equipment with leak detection can be used.

The ESB BREF [8, European IPPC Bureau, 2003] describes techniques used to prevent emissions to the environment from the storage and handling of solids, liquids and liquefied gases.

#### Achieved environmental benefits

- prevention of contamination to the ground, surface water and groundwater.

#### Cross-media effects

- no issues.

#### Operational data

Measures for ground protection depend on the hazard arising from a handled substance. Retention volumes used at some SIC plants are provided in Table 4.26.

Retention volumes		
The larger of the two factors		
Plant A	110 % of the capacity of the largest tank or drum	25 % of the total storage capacity
Plant B	100 % of the capacity of the largest tank or drum	10 % of the total storage capacity

Table 4.26: Examples from SIC plants for retention volumes

The following operating measures can be implemented:

- the integrity and tightness of all structure boundaries and their resistance to penetration by water or other substances are tested and demonstrated
- the loading and unloading of materials are carried out only in designated areas protected against leakage run-off. While awaiting disposal, all materials are collected and stored in designated areas protected against leakage run-off
- all pump sumps or other treatment plant chambers from which spillages might occur are equipped with alarms activated by high levels of liquid
- a programme for the testing and inspection of tanks and pipelines is established and carried out
- inspections are carried out for leaks on all flanges and valves on pipes used to transport materials other than water. A log of these inspections is maintained
- a catchment system is provided to collect any leaks from flanges and valves on pipes used to transport materials other than water, except when the construction of flanges or valves is technically tight
- an adequate supply of containment booms and suitable absorbent material is provided
- all bunds are tested at least once every three to five years.

### **Applicability**

- generally applicable.

### **Driving force for implementation**

- prevention of contamination to the ground, surface water and groundwater.

By regulation, all chemical installations in France, Germany and the Netherlands have to have ground protection measures.

### **Example plants**

- UEB plant in Galdácano, Spain
- Thermphos plants, Germany.

### **Reference literature**

ESB BREF [8, European IPPC Bureau, 2003].

## 4.7.2 High level of education and continuous training of personnel

### Description

The complex process to produce SIC, the use of modern technologies, the fact that highly toxic substances can be produced and that emergency situations can occur put a lot of stress on the plant personnel, in particular the plant operators. To ensure that incidents are kept to a minimum, accidents are prevented and in order to reduce the risk of error in emergency situations, specific education and training programmes are implemented. Besides a sound basic education in chemical engineering and operations, plant personnel are continuously trained on the jobs. Their skills can regularly be evaluated and performance can be recorded after written or practical exams. Additionally, all operators are regularly trained on how to respond to emergency situations, on health and safety at work, and on product and transportation safety regulations.

It should be noted that the techniques presented in Sections 4.7.3 and 4.7.6 also relate to the education and training of personnel.

### Achieved environmental benefits

- reduction of risks of incidents and accidents that could lead to emissions to the air, water and soil.

### Cross-media effects

- none.

### Applicability

- generally applicable.

### Economics

Better education and continuous training of personnel leads to better decision making when confronted by problems (including incidents and emergency situations) and finally to a reduction in production costs.

### Driving force for implementation

- enhanced safety standards leading to reduced environmental risks.

### Example plants

- CyPlus, Germany.

### 4.7.3 Application of an Industry Code (IC)

#### Description

Industry Codes (e.g. International Cyanide Management Code) are developed to ensure very high standards for safety, environmental and quality aspects in the production, transport and use of chemicals (e.g. cyanides) so that humans and the environment are protected. The application of the codes at SIC production plants entails activities such as auditing, certification, training of plant personnel.

#### Achieved environmental benefits

- reduction in the overall environmental impact of the production.

#### Cross-media effects

- none.

#### Applicability

- generally applicable.

#### Economics

There are no savings to be made from applying the code. Costs depend on the standards a SIC producer already has in place – it therefore means less costs for producers who already have a sound environmental management system in place, and higher costs for those who do not.

Auditing can take a day, internal preparations for the audit can take several days to several weeks with the respective, e.g. personnel costs involved.

#### Example plants

- CyPlus, Germany.

#### 4.7.4 Rainwater collection and treatment

##### Description

Because equipment and floors used in the production of SIC substances are not always protected from rain (i.e. by positioning equipment in closed buildings), it may be necessary to collect rainwater, to check whether it has been contaminated through leaching of equipment and floors and, if this is the case, to send it for treatment before release to the receiving water. Uncontaminated rainwater can be directly discharged to the receiving water provided appropriate monitoring conditions are respected.

Parameters to monitor and pollution prevention techniques to be applied based on the monitoring results will depend in particular on the activities carried out at the installation and their significance to any receiving water as well as on the rainfall intensity and duration, which have major regional variations. Typical parameters that may be monitored rapidly during periods of rainfall are, for example, pH, turbidity, TOC, colour, floating material. The frequency of monitoring (e.g. continuous, regular) depends on a combination of several factors such as the frequency of rainfall, the size of the installation (SMEs are generally less likely to use continuous monitoring and have more difficulties in storing rainwater), as well as the activities carried out at the installation and their significance to any receiving waters.

Some examples of pollution prevention techniques are given below.

Depending on the pollutant load, contaminated rainwater is often treated in a central (biological) waste water treatment plant or by using a storm-water clarifier (mechanical treatment). Arising sludge and scum are disposed of. Another option is to collect the first flush of storm-water in a storage tank and direct it to the treatment plant slowly; the overflow being discharged to the receiving water. In the case of sensitive rivers, the flowrate of the storm-water discharge/overflow should be limited to prevent erosion of the riverbed.

In order to prevent the release of contamination at the Marl chemical site in Germany, rainwater directly released to the receiving water (which is supposed to be uncontaminated) is continuously monitored for contamination as a precautionary procedure. If contamination is detected, the direct discharge to the receiving water is stopped and the rainwater is stored before being directed to treatment.

##### Achieved environmental benefits

- reduction of diffuse emissions to the receiving water
- prevention of major spills.

##### Cross-media effects

- none.



## Operational data

At the Marl chemical site, there is continuous monitoring of the following parameters in the rainwater and cooling water ducts:

- pH
- TOC (measured using a process analyser with a sampling frequency of one sample every three to five minutes)
- floating material
- turbidity (measured in a flow-through cell)
- toxicity to fish (measured in a flow-through fish tank with Golden Orf as the test species)
- volatile organic compounds (on a voluntary basis).

When elevated values are found (even for turbidity in the first flush of storm-water), rainwater is stored and treated at the central WWTP before being discharged to the Lippe river.

## Applicability

Continuous monitoring may not be economically viable at small installations with small volumes of rainwater compared to the total volume of waste water to be treated. These installations may choose to systematically duct rainwater to treatment irrespective of whether it is contaminated or not.

## Example plants

- Marl chemical site in Germany.

### 4.7.5 Safety assessment

Safety assessment is in this document as it can help prevent accidents with potentially significant environmental impacts. However, this subject could not be entirely dealt with in this document. The field of process safety is much wider than presented here and this section should be seen as providing a general overview.

#### 4.7.5.1 Physico-chemical safety assessment of chemical reactions

##### Description

A structured safety assessment for a reaction in a certain process in a given plant can be performed according to the scheme given in Figure 4.7. The assessment is carried out for normal operation (see Figure 4.8) and takes into account effects due to deviations of the chemical process and deviations in the operation of the plant (see Table 4.27).

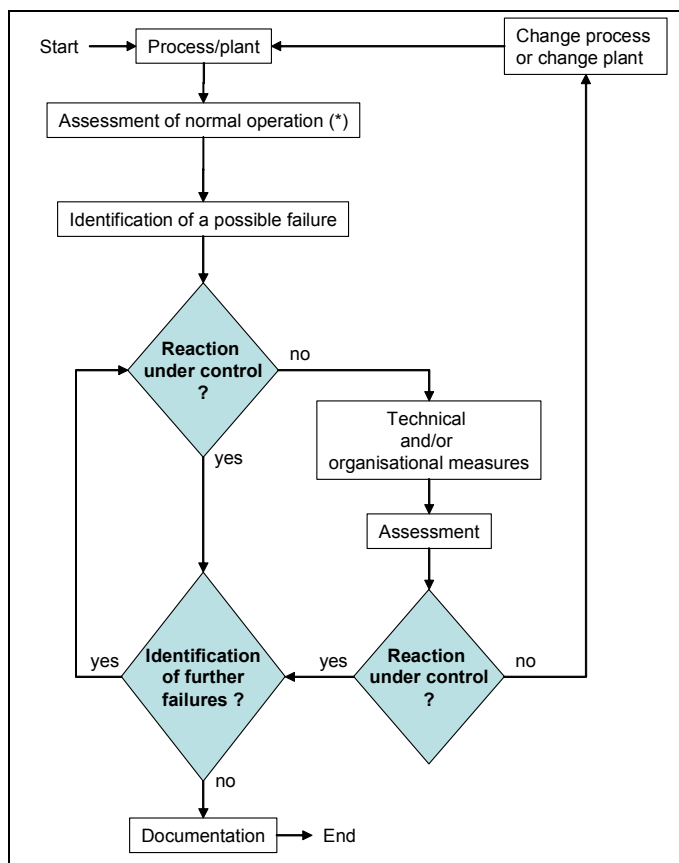

Figure 4.7: Safety assessment procedure  
 Note: (\*) see Figure 4.8

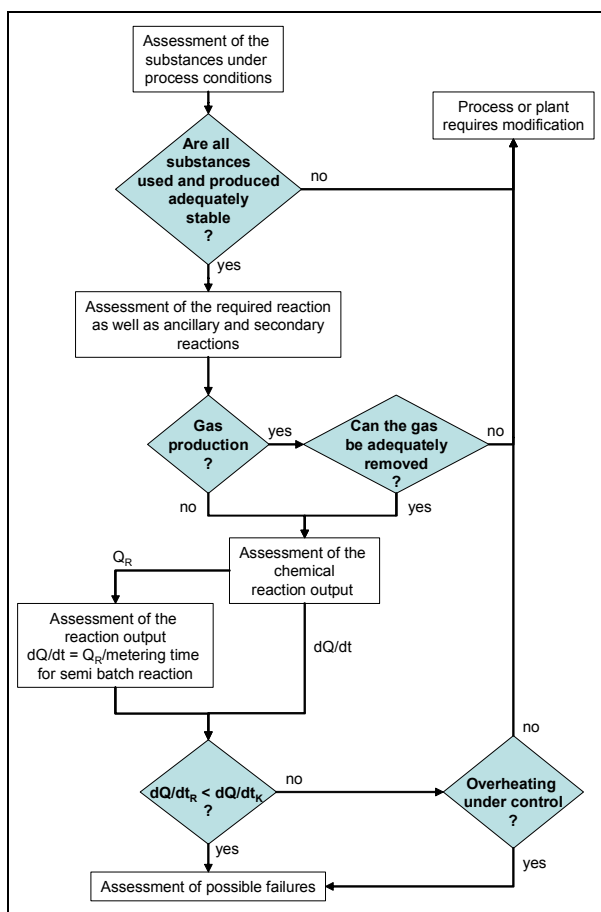

Figure 4.8: Iterative assessment strategy for normal operations

Failure caused by	$\Delta H_R$	dM/dt	$(dQ_R/dt) - (dQ_K/dt)$	$T_{exo}$	$\Delta n$ subst.
<b>Effects due to deviations of chemical processes</b>					
Starting materials (specification, nature, property), e.g. <ul style="list-style-type: none"> <li>contamination with catalytic effect</li> <li>increased/decreased concentration</li> <li>residues from previous use</li> <li>decomposition of activators/inhibitors (e.g. as a result of extended storage)</li> </ul>					
Presence of starting materials/auxiliary materials, e.g. <ul style="list-style-type: none"> <li>solvent used</li> <li>solution promoter</li> <li>activator/inhibitor</li> </ul>					
Metering, e.g. <ul style="list-style-type: none"> <li>wrong substance, wrong quantities/ratios</li> <li>changed metering sequence</li> <li>wrong metering rate</li> </ul>					
Reaction conditions, e.g. <ul style="list-style-type: none"> <li>change in pH value</li> <li>temperature increase/decrease</li> <li>reaction/residence time, delayed reaction start</li> <li>increase of by-products/residues</li> </ul>					
Mixing, e.g. <ul style="list-style-type: none"> <li>inadequate agitation</li> <li>separation of solids/catalysts</li> </ul>					
<b>Effects due to deviations in the operation of the plant</b>					
Availability of auxiliary energy, e.g. <ul style="list-style-type: none"> <li>compressed air, nitrogen</li> <li>electric current</li> <li>heating medium, cooling medium</li> <li>ventilation</li> </ul>					
Heating/cooling medium (temperature), e.g. <ul style="list-style-type: none"> <li>temperature exceeds/falls below the temperature defined for safe process operation</li> </ul>					
Process equipment, e.g. <ul style="list-style-type: none"> <li>failure</li> </ul>					
Material flows, e.g. <ul style="list-style-type: none"> <li>failure of pumps/valves</li> <li>incorrect operation of valves</li> <li>blocking of lines/valves/fittings (in particular venting pipes)</li> <li>backflow from other parts of the plant</li> </ul>					
Filling level, e.g. <ul style="list-style-type: none"> <li>overflowing</li> <li>leakage from a valve</li> <li>flooding of condensers (heat-exchangers)</li> </ul>					
Agitation, e.g. <ul style="list-style-type: none"> <li>failure</li> <li>increased viscosity</li> <li>mechanical introduction of heat</li> </ul>					
Integrity of components, e.g. <ul style="list-style-type: none"> <li>corrosion (in particular with resulting material overflow from/to heat transfer systems)</li> <li>mechanical damage</li> </ul>					

**Table 4.27: Template to analyse the effects due to deviations of chemical processes or to the operation of the plant**

All the relevant physico-chemical safety data of substances and reactions should be evaluated with respect to the necessary equipment along with technical and organisational safety precautions. Important physico-chemical parameters to be taken into account are, e.g:

- reaction enthalpies ( $\Delta H_R$ ) both for the reaction concerned and for potential secondary reactions (e.g. decomposition)
- possible gas evolution (M) and the rate of gas evolution (dM/dt) or corresponding derived parameters from the reaction or the possible decomposition
- rate of heat production (dQ<sub>R</sub>/dt), where appropriate as a function of temperature
- total heat removal capacity of the system (dQ<sub>K</sub>/dt)
- limit temperature (T<sub>exo</sub>) for the thermal stability of the substances concerned and the reaction mixtures under process conditions
- formation of new unwanted products or by-products ( $\Delta n$  subst.), which lead to an increase in the reaction enthalpy or gas formation or a reduction of the limit temperature (T<sub>exo</sub>).

Measures to ensure that a process can be controlled adequately include (without ranking):

Preventive measures	Design measures
(preferred) - organisational measures - concepts involving control engineering techniques - reaction stoppers - emergency cooling	- pressure resistant construction - pressure relief including sufficient catch volume

### Achieved environmental benefits

- prevention of major accidents and substance releases.

### Applicability

- similar to chemical reactions and also applicable to other operations, e.g. drying or distillation
- important safety examples are the handling of organic dusts or solvent vapours.

### Economics

- additional costs for safety measures
- high costs in the case of pressure resistant construction.

### Driving force for implementation

- process safety.

### Reference literature

OFC BREF [18, European IPPC Bureau, 2004].

### 4.7.5.2 Prevention of runaway reactions

#### Description

The consequences of a runaway reaction can be severe. Therefore, facilities must focus on prevention of conditions favourable for a reaction excursion through process design control, instrumentation, and interlocks to prevent the recurrence of similar events. Facilities should take the following steps to prevent runaway reactions:

- modify processes to improve inherent safety. Consider inherently safer processes to reduce reliance on administrative controls
- minimise the potential for human error
- understand events that may lead to an overpressure and eventually to vessel rupture
- use lessons learned. Go beyond the issues of quality control and operator error and identify true root causes
- evaluate Standard Operating Procedures (SOPs)
- evaluate employee training and oversight
- evaluate measures to inhibit a runaway reaction (e.g. neutralisation, quenching)
- evaluate the effectiveness of the emergency relief system.

#### Achieved environmental benefits

- prevention of runaway reactions and related consequences.

#### Applicability

- generally applicable, especially in the case of exothermic reactions
- also relevant for stored goods with potential for autoreaction.

#### Driving force for implementation

- prevention of accidents and consequent emissions to the environment.

#### References literature

OFC BREF [18, European IPPC Bureau, 2004].

## 4.7.6 Environmental management tools

### Description

The best environmental performance is usually achieved by the installation of the best technology and its operation in the most effective and efficient manner. This is recognised by the IPPC Directive definition of ‘techniques’ as “both the technology used and the way in which the installation is designed, built, maintained, operated and decommissioned”.

For IPPC installations an Environmental Management System (EMS) is a tool that operators can use to address these design, construction, maintenance, operation and decommissioning issues in a systematic, demonstrable way. An EMS includes the organisational structure, responsibilities, practices, procedures, processes and resources for developing, implementing, maintaining, reviewing and monitoring the environmental policy. Environmental Management Systems are most effective and efficient where they form an inherent part of the overall management and operation of an installation.

Within the European Union, many organisations have decided on a voluntary basis to implement environmental management systems based on EN ISO 14001: 2004 or the EU Eco-management and audit scheme EMAS. EMAS includes the management system requirements of EN ISO 14001, but places additional emphasis on legal compliance, environmental performance and employee involvement; it also requires external verification of the management system and validation of a public environmental statement (in EN ISO 14001 self-declaration is an alternative to external verification). There are also many organisations that have decided to put in place non-standardised EMSs.

While both standardised systems (EN ISO 14001: 2004 and EMAS) and non-standardised (“customised”) systems in principle take the organisation as the entity, this document takes a more narrow approach, not including all activities of the organisation e.g. with regard to their products and services, due to the fact that the regulated entity under the IPPC Directive is the installation (as defined in Article 2).

An environmental management system (EMS) for an IPPC installation can contain the following components:

- (a) definition of an environmental policy
- (b) planning and establishing objectives and targets
- (c) implementation and operation of procedures
- (d) checking and corrective action
- (e) management review
- (f) preparation of a regular environmental statement
- (g) validation by certification body or external EMS verifier
- (h) design considerations for end-of-life plant decommissioning
- (i) development of cleaner technologies
- (j) benchmarking.

These features are explained in somewhat greater detail below. For detailed information on components (a) to (g), which are all included in EMAS, the reader is referred to the reference literature indicated below.

(a) Definition of an environmental policy

Top management are responsible for defining an environmental policy for an installation and ensuring that it:

- is appropriate to the nature, scale and environmental impacts of the activities
- includes a commitment to pollution prevention and control
- includes a commitment to comply with all relevant applicable environmental legislation and regulations, and with other requirements to which the organisation subscribes
- provides the framework for setting and reviewing environmental objectives and targets
- is documented and communicated to all employees
- is available to the public and all interested parties.

(b) Planning, i.e.:

- procedures to identify the environmental aspects of the installation, in order to determine those activities which have or can have significant impacts on the environment, and to keep this information up-to-date
- procedures to identify and have access to legal and other requirements to which the organisation subscribes and that are applicable to the environmental aspects of its activities
- establishing and reviewing documented environmental objectives and targets, taking into consideration the legal and other requirements and the views of interested parties
- establishing and regularly updating an environmental management programme, including designation of responsibility for achieving objectives and targets at each relevant function and level as well as the means and timeframe by which they are to be achieved.

(c) Implementation and operation of procedures

It is important to have systems in place to ensure that procedures are known, understood and complied with, therefore effective environmental management includes:

(i) Structure and responsibility

- defining, documenting and communicating roles, responsibilities and authorities, which includes appointing one specific management representative
- providing resources essential to the implementation and control of the environmental management system, including human resources and specialised skills, technology and financial resources.

(ii) Training, awareness and competence

- identifying training needs to ensure that all personnel whose work may significantly affect the environmental impacts of the activity have received appropriate training.

(iii) Communication

- establishing and maintaining procedures for internal communication between the various levels and functions of the installation, as well as procedures that foster a dialogue with external interested parties and procedures for receiving, documenting and, where reasonable, responding to relevant communication from external interested parties.

(iv) Employee involvement

- involving employees in the process aimed at achieving a high level of environmental performance by applying appropriate forms of participation such as the suggestion-book system or project-based group works or environmental committees.

(v) Documentation

- establishing and maintaining up-to-date information, in paper or electronic form, to describe the core elements of the management system and their interaction and to provide direction to related documentation.

(vi) Efficient process control

- adequate control of processes under all modes of operation, i.e. preparation, start up, routine operation, shut down and abnormal conditions
- identifying the key performance indicators and methods for measuring and controlling these parameters (e.g. flow, pressure, temperature, composition and quantity)
- documenting and analysing abnormal operating conditions to identify the root causes and then addressing these to ensure that events do not recur (this can be facilitated by a ‘no-blame’ culture where the identification of causes is more important than apportioning blame to individuals).

(vii) Maintenance programme

- establishing a structured programme for maintenance based on technical descriptions of the equipment, norms, etc. as well as any equipment failures and consequences
- supporting the maintenance programme by appropriate record keeping systems and diagnostic testing
- clearly allocating responsibility for the planning and execution of maintenance.

(viii) Emergency preparedness and response

- establishing and maintaining procedures to identify the potential for and response to accidents and emergency situations, and for preventing and mitigating the environmental impacts that may be associated with them.

(d) Checking and corrective action, i.e.:

(i) Monitoring and measurement

- establishing and maintaining documented procedures to monitor and measure, on a regular basis, the key characteristics of operations and activities that can have a significant impact on the environment, including the recording of information for tracking performance, relevant operational controls and conformance with the installation's environmental objectives and targets (see also the Reference document on Monitoring of Emissions)
- establishing and maintaining a documented procedure for periodically evaluating compliance with relevant environmental legislation and regulations.

(ii) Corrective and preventive action

- establishing and maintaining procedures for defining responsibility and authority for handling and investigating non-conformance with permit conditions, other legal requirements as well as objectives and targets, taking action to mitigate any impacts caused and for initiating and completing corrective and preventive action that are appropriate to the magnitude of the problem and commensurate with the environmental impact encountered.

(iii) Records

- establishing and maintaining procedures for the identification, maintenance and disposition of legible, identifiable and traceable environmental records, including training records and the results of audits and reviews.



## (iv) Audit

- establishing and maintaining (a) programme(s) and procedures for periodic environmental management system audits that include discussions with personnel, inspection of operating conditions and equipment and reviewing of records and documentation and that results in a written report, to be carried out impartially and objectively by employees (internal audits) or external parties (external audits), covering the audit scope, frequency and methodologies, as well as the responsibilities and requirements for conducting audits and reporting results, in order to determine whether or not the environmental management system conforms to planned arrangements and has been properly implemented and maintained
- completing the audit or audit cycle, as appropriate, at intervals of no longer than three years, depending on the nature, scale and complexity of the activities, the significance of associated environmental impacts, the importance and urgency of the problems detected by previous audits and the history of environmental problems – more complex activities with a more significant environmental impact are audited more frequently
- having appropriate mechanisms in place to ensure that the audit results are followed up.

## (v) Periodic evaluation of legal compliance

- reviewing compliance with the applicable environmental legislation and the conditions of the environmental permit(s) held by the installation
- documentation of the evaluation.

## (e) Management review, i.e.:

- reviewing, by top management, at intervals that it determines, the environmental management system, to ensure its continuing suitability, adequacy and effectiveness
- ensuring that the necessary information is collected to allow management to carry out this evaluation
- documentation of the review.

## (f) Preparation of a regular environmental statement:

- preparing an environmental statement that pays particular attention to the results achieved by the installation against its environmental objectives and targets. It is regularly produced – from once a year to less frequently depending on the significance of emissions, waste generation, etc. It considers the information needs of relevant interested parties and it is publicly available (e.g. in electronic publications, libraries, etc.).

When producing a statement, the operator may use relevant existing environmental performance indicators, making sure that the indicators chosen:

- i. give an accurate appraisal of the installation's performance
- ii. are understandable and unambiguous
- iii. allow for year on year comparison to assess the development of the environmental performance of the installation
- iv. allow for comparison with sector, national or regional benchmarks as appropriate
- v. allow for comparison with regulatory requirements as appropriate.

## (g) Validation by certification body or external EMS verifier:

- having the management system, audit procedure and environmental statement examined and validated by an accredited certification body or an external EMS verifier can, if carried out properly, enhance the credibility of the system.

(h) Design considerations for end-of-life plant decommissioning:

- giving consideration to the environmental impact from the eventual decommissioning of the unit at the stage of designing a new plant, as forethought makes decommissioning easier, cleaner and cheaper
- decommissioning poses environmental risks for the contamination of land (and groundwater) and generates large quantities of solid waste. Preventive techniques are process-specific but general considerations may include:
  - i. avoiding underground structures
  - ii. incorporating features that facilitate dismantling
  - iii. choosing surface finishes that are easily decontaminated
  - iv. using an equipment configuration that minimises trapped chemicals and facilitates drain-down or washing
  - v. designing flexible, self-contained units that enable phased closure
  - vi. using biodegradable and recyclable materials where possible.

(i) Development of cleaner technologies:

- environmental protection should be an inherent feature of any process design activities carried out by the operator, since techniques incorporated at the earliest possible design stage are both more effective and cheaper. Giving consideration to the development of cleaner technologies can for instance occur through R&D activities or studies. As an alternative to internal activities, arrangements can be made to keep abreast with – and where appropriate – commission work by other operators or research institutes active in the relevant field.

(j) Benchmarking, i.e.:

- carrying out systematic and regular comparisons with sector, national or regional benchmarks, including for energy efficiency and energy conservation activities, choice of input materials, emissions to air and discharges to water (using for example the European Pollutant Emission Register, EPER), consumption of water and generation of waste.

### **Standardised and non-standardised EMSs**

An EMS can take the form of a standardised or non-standardised (“customised”) system. Implementation and adherence to an internationally accepted standardised system such as EN ISO 14001: 2004 can give higher credibility to the EMS, especially when subject to a properly performed external verification. EMAS provides additional credibility due to the interaction with the public through the environmental statement and the mechanism to ensure compliance with the applicable environmental legislation. However, non-standardised systems can in principle be equally effective provided that they are properly designed and implemented.

### **Achieved environmental benefits**

Implementation of and adherence to an EMS focuses the attention of the operator on the environmental performance of the installation. In particular, the maintenance of and compliance with clear operating procedures for both normal and abnormal situations and the associated lines of responsibility should ensure that the installation’s permit conditions and other environmental targets and objectives are met at all times.

Environmental management systems typically ensure the continuous improvement of the environmental performance of the installation. The poorer the starting point is, the more significant short-term improvements can be expected. If the installation already has a good overall environmental performance, the system helps the operator to maintain the high performance level.

### **Cross-media effects**

Environmental management techniques are designed to address the overall environmental impact, which is consistent with the integrated approach of the IPPC Directive.

### **Operational data**

No specific information reported.

### **Applicability**

The components described above can typically be applied to all IPPC installations. The scope (e.g. level of detail) and nature of the EMS (e.g. standardised or non-standardised) will generally be related to the nature, scale and complexity of the installation, and the range of environmental impacts it may have.

### **Economics**

It is difficult to accurately determine the costs and economic benefits of introducing and maintaining a good EMS. A number of studies are presented below. However, these are just examples and their results are not entirely coherent. They might not be representative for all sectors across the EU and should thus be treated with caution.

A Swedish study carried out in 1999 surveyed all 360 ISO-certified and EMAS-registered companies in Sweden. With a response rate of 50 %, it concluded among other things that:

- the expenses for introducing and operating EMS are high but not unreasonably so, save in the case of very small companies. Expenses are expected to decrease in the future
- a higher degree of co-ordination and integration of EMS with other management systems is seen as a possible way to decrease costs
- half of all the environmental objectives and targets give payback within one year through cost savings and/or increased revenue
- the largest cost savings were made through decreased expenditure on energy, waste treatment and raw materials
- most of the companies think that their position on the market has been strengthened through the EMS. One-third of the companies report increasing revenue due to EMS.

In some Member States reduced supervision fees are charged if the installation has a certification.

A number of studies show that there is an inverse relationship between company size and the cost of implementing an EMS. A similar inverse relationship exists for the payback period of invested capital. Both elements imply a less favourable cost-benefit relationship for implementing an EMS in SMEs compared to larger companies.

According to a Swiss study, the average cost for building and operating ISO 14001 can vary:

- for a company with between 1 and 49 employees: CHF 64000 (EUR 44000) for building the EMS and CHF 16000 (EUR 11000) per year for operating it
- for an industrial site with more than 250 employees: CHF 367000 (EUR 252000) for building the EMS and CHF 155000 (EUR 106000) per year for operating it.

These average figures do not necessarily represent the actual cost for a given industrial site because this cost is also highly dependent on the number of significant items (pollutants, energy consumption...) and on the complexity of the problems to be studied.

A recent German study (Schaltegger, Stefan and Wagner, Marcus, Umweltmanagement in deutschen Unternehmen - der aktuelle Stand der Praxis, February 2002, p. 106) shows the following costs for EMAS for different branches. It can be noted that these figures are much lower than those of the Swiss study quoted above. This is a confirmation of the difficulty to determine the costs of an EMS.

### Costs for building (EUR):

minimum	- 18750
maximum	- 75000
average	- 50000

### Costs for validation (EUR):

minimum	- 5000
maximum	- 12500
average	- 6000

A study by the German Institute of Entrepreneurs (Unternehmerinstitut/Arbeitsgemeinschaft Selbständiger Unternehmer UNI/ASU, 1997, Umweltmanagementbefragung – Öko-Audit in der mittelständischen Praxis – Evaluierung und Ansätze für eine Effizienzsteigerung von Umweltmanagementsystemen in der Praxis, Bonn.) gives information about the average savings achieved for EMAS per year and the average payback time. For example, for implementation costs of EUR 80000 they found average savings of EUR 50000 per year, corresponding to a payback time of about one and a half years.

External costs relating to verification of the system can be estimated from guidance issued by the International Accreditation Forum (<http://www.iaf.nu>).

## **Driving forces for implementation**

Environmental management systems can provide a number of advantages, for example:

- improved insight into the environmental aspects of the company
- improved basis for decision-making
- improved motivation of personnel
- additional opportunities for operational cost reduction and product quality improvement
- improved environmental performance
- improved company image
- reduced liability, insurance and non-compliance costs
- increased attractiveness for employees, customers and investors
- increased trust of regulators, which could lead to reduced regulatory oversight
- improved relationship with environmental groups.

## **Example plants**

The features described under (a) to (e) above are elements of EN ISO 14001: 2004 and the European Community Eco-Management and Audit Scheme (EMAS), whereas the features (f) and (g) are specific to EMAS. These two standardised systems are applied in a number of IPPC installations. As an example, 357 organisations within the EU chemical and chemical products industry (NACE code 24) were EMAS registered in July 2002, most of which operate IPPC installations.

In the UK, the Environment Agency of England and Wales carried out a survey among IPC (the precursor to IPPC) regulated installations in 2001. It showed that 32 % of respondents were certified to ISO 14001 (corresponding to 21 % of all IPC installations) and 7 % were EMAS registered. All cement works in the UK (around 20) are certified to ISO 14001 and the majority are EMAS registered. In Ireland, where the establishment of an EMS (not necessarily of a standardised nature) is required in IPC licenses, an estimated 100 out of approximately 500 licensed installations have established an EMS according to ISO 14001, with the other 400 installations having opted for a non-standardised EMS.

### **Reference literature**

(Regulation (EC) No 761/2001 of the European parliament and of the council allowing voluntary participation by organisations in a Community eco-management and audit scheme (EMAS), OJ L 114, 24/4/2001, [http://europa.eu.int/comm/environment/emas/index\\_en.htm](http://europa.eu.int/comm/environment/emas/index_en.htm))

(EN ISO 14001: 2004, <http://www.iso.ch/iso/en/iso9000-14000/iso14000/iso14000index.html>;  
<http://www.tc207.org>)



## 5 GENERIC BEST AVAILABLE TECHNIQUES

In understanding this chapter and its contents, the attention of the reader is drawn back to the preface of this document and in particular the fifth section of the preface: 'How to understand and use this document'. The techniques and associated consumption and/or emission levels, or ranges of levels, presented in this chapter have been assessed through an iterative process involving the following steps:

- identification of the key environmental issues for the sector
- examination of the techniques most relevant to address these key issues
- identification of the best environmental performance levels, on the basis of the available data in the European Union and worldwide
- examination of the conditions under which these performance levels were achieved; such as costs, cross-media effects, and the main driving forces involved in implementation of the techniques
- selection of the Best Available Techniques (BAT) and the associated consumption and/or emission levels for this sector in a general sense, all according to Article 2(11) and Annex IV to the Directive.

Expert judgment by the European IPPC Bureau and the relevant Technical Working Group (TWG) has played a key role in each of these steps and in the way in which the information is presented here.

On the basis of this assessment, techniques, and as far as possible consumption and emission levels associated with the use of BAT, are presented in this chapter that are considered to be appropriate to the sector as a whole and in many cases reflect the current performance of some installations within the sector. Where consumption or emission levels 'associated with Best Available Techniques' are presented, this is to be understood as meaning that those levels represent the environmental performance that could be anticipated as a result of the application, in this sector, of the techniques described, bearing in mind the balance of costs and advantages inherent within the definition of BAT. However, they are neither consumption nor emission limit values and should not be understood as such. In some cases it may be technically possible to achieve better consumption or emission levels but due to the costs involved or cross-media considerations, they are not considered to be appropriate as BAT for the sector as a whole. However, such levels may be considered to be justified in more specific cases where there are special driving forces.

The consumption and emission levels associated with the use of BAT have to be seen together with any specified reference conditions (e.g. averaging periods).

The concept of 'levels associated with BAT' described above is to be distinguished from the term 'achievable level' used elsewhere in this document. Where a level is described as 'achievable' using a particular technique or combination of techniques, this should be understood to mean that the level may be expected to be achieved over a substantial period of time in a well maintained and operated installation or process using those techniques.

Where available, data concerning costs have been given together with the description of the techniques presented in the previous chapter. These give a rough indication about the magnitude of the costs involved. However, the actual cost of applying a technique will depend strongly on the specific situation regarding, for example, taxes, fees, and the technical characteristics of the installation concerned. It is not possible to evaluate such site-specific factors fully in this document. In the absence of data concerning costs, conclusions on economic viability of techniques are drawn from observations on existing installations.

It is intended that the general BAT in this chapter are a reference point against which to judge the current performance of an existing installation or to judge a proposal for a new installation. In this way they will assist in the determination of appropriate 'BAT-based' conditions for the installation or in the establishment of general binding rules under Article 9(8). It is foreseen that new installations can be designed to perform at or even better than the general BAT levels presented here. It is also considered that existing installations could move towards the general BAT levels or do better, subject to the technical and economic applicability of the techniques in each case.

While the BAT reference documents do not set legally binding standards, they are meant to give information for the guidance of industry, Member States and the public on achievable consumption and emission levels when using specified techniques. The appropriate limit values for any specific case will need to be determined taking into account the objectives of the IPPC Directive and the local considerations.

### Recommendations to help users/readers of this document

The following issues are considered important enough for those who read this document:

- it is strongly recommended to read Chapter 5 in conjunction with Chapter 4. To help the reader in this, references to Chapter 4 have been included in Chapter 5
- in addition to the BAT referenced in this chapter, BAT for a SIC installation will also contain elements from other IPPC documents. In this context, special attention is drawn to the following BAT Reference Documents:
  - Emissions from Storage (ESB BREF, [8, European IPPC Bureau, 2003])
  - Industrial Cooling Systems (CV BREF, [31, European IPPC Bureau, 2000])
  - Waste Water and Waste Gas Treatment/Management Systems in the Chemical Sector (CWW BREF, [21, European IPPC Bureau, 2003])
  - Waste Incineration (WI BREF, [34, European IPPC Bureau, 2004])
  - Waste Treatments (WT BREF, [35, European IPPC Bureau, 2004])
  - General Principles of Monitoring (MON BREF, [36, European IPPC Bureau, 2003]).

With regard to the CWW BREF [21, European IPPC Bureau, 2003], it is worth noting the following points:

- this SIC document allows a more in-depth look into the application of some of the environmentally beneficial techniques identified in the CWW BREF [21, European IPPC Bureau, 2003] for the production of SIC
- in order to reduce the need for the reader of this document to consult the CWW BREF [21, European IPPC Bureau, 2003], Chapter 4 of this document briefly presents techniques that are described in more detail in the CWW BREF [21, European IPPC Bureau, 2003]. This also offers the advantage of including operational data derived from, and specific to, the SIC sector for each technique considered.

In this document, the BAT conclusions for the SIC sector are set out on two levels. Chapter 5 presents generic BAT conclusions, i.e. those that are generally applicable to the whole sector. If there are exceptions when the BAT is not applicable in certain circumstances or cases, this issue is mentioned in the BAT conclusion. Sections 6.X.5 (i.e. Section 6.1.5, Section 6.2.5, Section 6.3.5, Section 6.4.5, Section 6.5.5) contain more specific BAT conclusions, i.e. those for the families of SIC substances under the scope.



### Raw and auxiliary materials supply, storage, handling and preparation

BAT is to:

- 5.1 reduce the amount of packaging materials disposed of by, e.g. recycling 'hard' and 'soft' used packaging materials (see Sections 4.2.1 and 4.2.2), unless safety or hazard considerations prevent it.

### Synthesis/reaction/calcination

BAT is to:

- 5.2 reduce emissions and the amount of residues generated by implementing one or more of the following measures:
  - a. using high purity feedstock (see Section 4.3.1)
  - b. improving reactor efficiencies (see Section 4.3.2)
  - c. improving catalyst systems (see Section 4.3.3).

For discontinuous processes, BAT is to:

- 5.3 optimise yields, lower emissions and reduce waste by sequencing the addition of reactants and reagents (see Section 4.3.4).

For discontinuous processes, BAT is to:

- 5.4 minimise cleaning operations by optimising the sequences for addition of raw and auxiliary materials (see Section 4.3.4).

### Product handling and storage

BAT is to:

- 5.5 reduce the amount of residues generated by, e.g. using returnable product transportation containers/drums (see Section 4.2.1).

### Waste gas emissions abatement

BAT is to:

- 5.6 minimise emissions of total dust in off-gases and achieve emission levels of 1 - 10 mg/Nm<sup>3</sup> by using one or more of the following techniques:
  - a. cyclone (see Section 4.4.2.1.2)
  - b. fabric or ceramic filter (see Section 4.4.2.1.5)
  - c. wet dust scrubber (see Section 4.4.2.1.3)
  - d. ESP (see Section 4.4.2.1.4).

The lower end of the range may be achieved by using fabric filters in combination with other abatement techniques. However, the range may be higher, depending on the carrier gas and particle characteristics (see Section 4.4.2.1). Using fabric filters is not always possible e.g. when other pollutants have to be abated (e.g. SO<sub>x</sub>) or when the off-gases present humid conditions (e.g. presence of liquid acid).

The particulate matters recovered/removed are recycled back into production when this is feasible. The scrubbing medium is recycled when this is feasible.

BAT is to:

- 5.7 reduce HCN emissions and achieve emission levels of <1 mg/m<sup>3</sup> by scrubbing with an alkaline solution. The scrubbing medium is recycled when this is feasible (see Section 4.4.2.2.5).

BAT is to:

5.8 reduce NH<sub>3</sub> emissions and achieve emission levels of <1.2 mg/m<sup>3</sup> by scrubbing with an acidic solution. The scrubbing medium is recycled when this is feasible (see Section 4.4.2.2.5).

BAT is to:

5.9 reduce HCl emissions, e.g. by wet gas scrubbing under alkaline conditions (see Section 4.4.2.2.4). If HCl is the main pollutant to be treated and alkali scrubbing is used, BAT is to achieve 3 – 10 mg/Nm<sup>3</sup> HCl.

### Waste water management and water emissions abatement

Waste water treatment in the SIC sector follows at least three different strategies:

- pretreatment within the premises of the SIC installation and final treatment(s) in a central WWTP within the premises of a larger site where the SIC installation is located
- pretreatment and/or final treatment(s) in a WWTP within the premises of the SIC installation
- pretreatment within the premises of the SIC installation and final treatment(s) in a municipal WWTP.

This document gives no preference to any of these strategies. All three strategies are considered as BAT when properly applied to the actual waste water situation provided that Article 2(6) regarding indirect releases to water is observed.

The approach follows a decision pathway to come to BAT conclusions for appropriate waste water treatment for a chemical site, which is illustrated in Figure 4.1.

No generic BAT conclusions on the abatement of heavy metals in waste water were derived. However, BAT conclusions on heavy metals abatement from waste water specific to three of the five illustrative families of SIC substances addressed in this document have been drawn: for speciality inorganic pigments (see Section 6.1.5, BAT 6.1.11 and BAT 6.1.12), for silicones (see Section 6.3.5, BAT 6.3.14) and for inorganic explosives (see Section 6.4.5, BAT 6.4.7). For information on heavy metals abatement in the production of substances not covered in the illustrative families sections of this document, it is recommended to refer to the CWW BREF [21, European IPPC Bureau, 2003].

As a general measure, BAT is to:

5.10 allocate contaminated waste water streams according to their pollutant load. Inorganic waste water without relevant organic components is segregated from organic waste water and ducted to special treatment facilities (see Section 4.4.1 and Figure 4.1).

For rainwater, BAT is to:

5.11 minimise pollution to receiving watercourses by applying all of the following measures:

- a. minimising the contamination of rainwater from activities carried out at the installation in particular by applying measures for reducing fugitive and diffuse emissions (see BAT 5.12 and BAT 5.13 and BAT 5.17)
- b. ducting and storing rainwater (see Section 4.7.4) expected to be contaminated from activities carried out at the installation and treating it if necessary. Other rainwater may be directly discharged (see Section 4.7.4)
- c. monitoring the discharge of this other rainwater as outlined in Section 4.7.4. Rainwater found to be contaminated is treated as in b. above (see Section 4.7.4).

In some cases, the use of rainwater as process water to reduce fresh water consumption may be environmentally beneficial.

Infrastructure

For diffuse emissions, BAT is to:

- 5.12 minimise diffuse dust emissions where dust may arise (in particular from the storage and handling of materials/products) by applying one or more of the following techniques:
- a. storing materials in closed systems (e.g. silos, see Section 6.3.4.1)
  - b. using covered areas protected from rain and wind (see Section 6.3.4.1)
  - c. having production equipment, e.g. conveyors, totally or partially enclosed (see Section 2.2)
  - d. having equipment designed with hooding and ducting to capture diffuse dust emissions (e.g. during loading into storage) and abating it (e.g. using a fabric filter, see Section 6.3.4.1)
  - e. carrying out housekeeping regularly, e.g. by vacuuming (see Section 4.7.6).
- 5.13 minimise fugitive gaseous and liquid emissions by applying (according to the substances that may require controlling) one or more of the following techniques:
- a. having periodic leak detection and repair programmes (see Sections 4.7.1 and 2.6.6)
  - b. operating equipment at slightly below atmospheric pressure (see Section 6.3.4.16)
  - c. replacing flanges by welded connections (see Section 2.6)
  - d. using seal-less pumps and bellow valves (see Section 2.6)
  - e. using high performance sealing systems (e.g. effective gaskets and flanges, valves and pumps with high integrity packing, see Section 2.6)
  - f. carrying out housekeeping regularly (see Section 4.7.6).

For new installations, BAT is to:

- 5.14 use a computerised control system to operate the plant (see Section 4.5.2). However, this does not apply where safety issues do not permit automatic operations (e.g. in the production of SIC explosives).

For installations where solid hazardous compounds can build up in pipelines, machines and vessels, BAT is to:

- 5.15 have in place a closed cleaning and rinsing system (see Section 4.5.1).

Energy

BAT is to:

- 5.16 reduce the consumption of energy by optimising plant design, construction and operation, e.g. by using pinch methodology, except if safety issues prevent it (see Section 4.6.1).

Cross-boundary techniques

BAT is to:

- 5.17 minimise soil and groundwater pollution by designing, building, operating and maintaining facilities, where substances (usually liquids) which represent a potential risk of contamination of ground and groundwater are handled, in such a way that material escapes are minimised (see Section 4.7.1). This includes all of the following:
- a. having facilities sealed, stable and sufficiently resistant against possible mechanical, thermal or chemical stress. This is particularly important for highly toxic substances – e.g. cyanides, phosphorus compounds
  - b. providing sufficient retention volumes to safely retain spills and leaking substances in order to enable treatment or disposal

- c. providing sufficient retention volume to safely retain fire fighting water and contaminated surface water
- d. carrying out loading and unloading only in designated areas protected against leakage run-off
- e. storing and collecting materials awaiting disposal in designated areas protected against leakage run-off
- f. fitting all pump sumps or other treatment plant chambers from which spillage might occur with high liquid level alarms or having pump sumps regularly inspected by personnel
- g. establishing programmes for testing and inspecting tanks and pipelines including flanges and valves
- h. providing spill control equipment, such as containment booms and suitable absorbent material
- i. testing and demonstrating the integrity of bunds
- j. equipping tanks with overfill prevention
- k. storing materials/products in covered areas to keep rainfall out.

BAT is to:

- 5.18 have a high level of education and continuous training of personnel (see Section 4.7.2). This includes all of the following:
- a. having personnel with sound basic education in chemical engineering and operations
  - b. continuously training plant personnel on the jobs
  - c. regularly evaluating and recording the performance of personnel
  - d. regularly training personnel on how to respond to emergency situations, health and safety at work, and on product and transportation safety regulations.

BAT is to:

- 5.19 apply, if available, the principles of an Industry Code (see Section 4.7.3). This includes all of the following:
- a. applying very high standards for safety, environmental and quality aspects in the production of the SIC substances
  - b. carrying out activities such as auditing, certification, training of plant personnel (related to BAT number 5.18 and 5.22).

BAT is to:

- 5.20 carry out a structured safety assessment for normal operation and to take into account effects due to deviations of the chemical process and deviations in the operation of the plant (see Section 4.7.5).

In order to ensure that a process can be controlled adequately, BAT is to:

- 5.21 apply one individual or a combination of the following techniques (without ranking, see Section 4.7.5):
- a. organisational measures
  - b. concepts involving control engineering techniques
  - c. reaction stoppers (e.g. neutralisation, quenching)
  - d. emergency cooling
  - e. pressure resistant construction
  - f. pressure relief.

A number of environmental management techniques are determined as BAT. The scope (e.g. level of detail) and nature of the EMS (e.g. standardised or non-standardised) will generally be related to the nature, scale and complexity of the installation, and the range of environmental impacts it may have. BAT is to:

- 5.22 implement and adhere to an Environmental Management System (EMS) that incorporates, as appropriate to individual circumstances, the following features (see Section 4.7.6):

- a. definition of an environmental policy for the installation by top management (commitment of the top management is regarded as a precondition for the successful application of other features of the EMS)
- b. planning and establishing the necessary procedures
- c. implementation of the procedures, paying particular attention to:
  - structure and responsibility
  - training, awareness and competence
  - communication
  - employee involvement
  - documentation
  - efficient process control
  - maintenance programmes
  - emergency preparedness and response
  - safeguarding compliance with environmental legislation
- d. checking performance and taking corrective action, paying particular attention to:
  - monitoring and measurement (see also the Reference Document on General Principles of Monitoring)
  - corrective and preventive action
  - maintenance of records
  - independent (where practicable) internal auditing in order to determine whether or not the environmental management system conforms to planned arrangements and has been properly implemented and maintained
- e. review by top management.

Three further features, which can complement the above stepwise, are considered as supporting measures. However, their absence is generally not inconsistent with BAT. These three additional steps are:

- f. having the management system and audit procedure examined and validated by an accredited certification body or an external EMS verifier
- g. preparation and publication (and possibly external validation) of a regular environmental statement describing all the significant environmental aspects of the installation, allowing for year-by-year comparison against environmental objectives and targets as well as with sector benchmarks as appropriate
- h. implementation and adherence to an internationally accepted voluntary system such as EMAS and EN ISO 14001:1996. This voluntary step could give higher credibility to the EMS. In particular EMAS, which embodies all the above-mentioned features, gives higher credibility. However, non-standardised systems can, in principle, be equally effective provided that they are properly designed and implemented.

Specifically for the SIC sector, it is also important to consider the following potential features of the EMS:

- i. the environmental impact from the eventual decommissioning of the unit at the stage of designing a new plant
- j. the development of cleaner technologies
- k. where practicable, the application of sectoral benchmarking on a regular basis, including energy efficiency and energy conservation activities, choice of input materials, emissions to air, discharges to water, consumption of water and generation of waste.



## 6 ILLUSTRATIVE FAMILIES OF SPECIALITY INORGANIC CHEMICALS

### 6.1 Speciality inorganic pigments

With the notable exception of titanium dioxide ( $\text{TiO}_2$ ) and carbon black, inorganic pigments produced industrially by chemical processes (that is most of the inorganic pigments used) are considered *speciality chemicals* according to the definition adopted for the purpose of the SIC BREF work. Titanium dioxide (a white pigment which is the largest inorganic pigment produced worldwide) and carbon black are considered large volume chemicals and are, therefore, addressed in the LVIC-S BREF [24, European IPPC Bureau, 2004].

As a consequence, in this section, the terms ‘inorganic pigments’ and ‘speciality inorganic pigments’ are used interchangeably and refer to the family of inorganic pigments produced industrially by chemical processes excluding titanium dioxide and carbon black.

The industrial production of organic pigments and dyes by chemical processes (pigments are defined as colouring agents that are practically insoluble in an application medium, whereas dyes are colouring agents that are soluble in an application medium) is addressed in the Reference Document on Best Available Techniques for the Manufacture of Organic Fine Chemicals [18, European IPPC Bureau, 2004].

As the information contained in this document focuses on inorganic pigments produced industrially by chemical processes, the production of natural (mined) pigments (e.g. iron oxide pigments such as haematite goethite) is not addressed in this document.

#### 6.1.1 General information

[10, ANFFECC/CERAMICOLOR/EPSOM/VdMi, 1998] [17, Rudolph and Köppke, 2003]

Inorganic pigments are insoluble, fine particulate solid colourants, whose optical effects are based on selective (in the case of white pigments also on non-selective) light absorption and on light scattering. They are physically and chemically stable and unaffected by the vehicle or substrate in which they are incorporated.

Inorganic pigments can be classified into different categories according to their use as colourants:

- **white pigments:** e.g. zinc sulphide pigments (i.e. pure zinc sulphide and Lithopone – composed of a mixture of barium sulphate and zinc sulphide), barium sulphate, zinc oxide
- **coloured pigments:** e.g. iron oxides (red, orange, yellow, brown), cobalt blue, cadmium sulphide, chromium yellow, Complex Inorganic Coloured (CIC) pigments, bismuth vanadate pigments
- **black pigments:** e.g. black iron oxide, iron chromium black.

Besides their function for the colouring of materials, they can also be classified as follows:

- **magnetic data storage pigments:** e.g. iron oxides (doped or non-doped), chromium oxide, metallic iron pigments, barium ferrite pigments
- **corrosion-inhibiting pigments:** e.g. phosphate pigments, borate pigments, chromate pigments
- **interference pigments:** e.g. on the basis of mica and titanium dioxide
- **transparent pigments:** e.g. iron oxide, cobalt blue
- **phosphorescent pigments:** e.g. alkaline earth sulphides
- **fillers:** e.g. calcium carbonate, synthetic amorphous silica.

Nearly all inorganic pigments are oxides, sulphides, oxide hydroxides, silicates, sulphates or carbonates. They generally consist of particles with uniform chemical composition with the exception of effect pigments and mixtures of different pigments.

### 6.1.1.1 Uses

The main uses of pigments are in paints and varnishes, plastics, printing inks for paper, textiles and leather, construction materials, cosmetics and ceramics.

The following properties are important when determining the use of pigments:

- general physico-chemical properties: chemical structure, humidity content, salt content, content of substances soluble in water and/or acid, particles size distribution, density and hardness
- resistance to light, heat, weather conditions and chemicals (maintaining stable optical and anti-corrosive properties)
- properties in combination with the coating system (e.g. dispersion ability, compatibility with certain binders).

Table 6.1 gives the main application fields for some inorganic pigments in Western Europe.

Application fields	Iron oxides	Chromium oxides	CIC
Paints and varnishes	29 %	50 %	30 %
Construction materials	60 %	25 %	5 %
Plastics	6 %	10 %	45 %
Inks for paper	2 %	-	-
Ceramics and enamels	1 %	7 %	20 %
Others	2 %	8 %	-

**Table 6.1: Main application fields for some inorganic pigments in Western Europe**

In Europe, inorganic pigments are produced in installations mainly located in Germany, Italy and Spain. Production of pigments are also reported in France, Portugal, the United Kingdom and the Netherlands.

#### 6.1.1.1.1 Iron oxide pigments

Iron oxide pigments represent the main group of coloured pigments. Worldwide production in 1995 amounted to 600000 tonnes of synthetic pigments (pigments produced by chemical processes) and some 110000 to 120000 tonnes of natural (mined) pigments. The growing importance of iron oxide pigments is based on their chemical stability, large hue variety (yellow, orange, red, brown, black) and competitive prices compared to CIC and organic pigments. Iron oxides consist of chemically very different colouring substances, such as:

- $\alpha$ -FeOOH (yellow)
- $\gamma$ -FeOOH (yellow-orange)
- Fe<sub>3</sub>O<sub>4</sub> (black)
- $\gamma$ -Fe<sub>2</sub>O<sub>3</sub> (brown)
- $\alpha$ -Fe<sub>2</sub>O<sub>3</sub> (red).



The high demand of pigments for the paints and construction materials industries can virtually be satisfied by synthetic iron oxide pigments. They possess the required chemical purity and can be produced in different particle sizes, which enables variation in both hiding power and hues to be achieved. Iron oxide pigments attain their maximum scattering power at a particle size of about 0.2  $\mu\text{m}$ , the hiding power being lower for both larger and smaller particles. Particles smaller than 0.01  $\mu\text{m}$  lose their scattering power completely and are used for transparent colourants. Hues of synthetic iron oxide pigments can be adjusted by the selection of different qualities and particle sizes.

#### **6.1.1.1.2 Complex Inorganic Coloured (CIC) pigments**

Formerly named ‘mixed-phase metal oxide pigments’, Complex Inorganic Coloured (CIC) pigments have been renamed in order to express the fact that these pigments are not a mixture, but consist of a stable crystal lattice of different metal cations. The most important host-lattices are rutile, spinel, zircon, and haematite/corundum, but other stable structures exist.

Various CIC pigments are shown in Table 6.2.

CIC pigment system	CIC pigment common name	CIC pigment formula
Rutile pigments	Chromium antimony yellow	$(\text{Ti,Cr,Sb})\text{O}_2$
	Nickel antimony yellow	$(\text{Ti,Ni,Sb})\text{O}_2$
	Manganese antimony brown	$(\text{Ti,Mn,Sb})\text{O}_2$
	Chromium tungsten brown	$(\text{Ti,Cr,W})\text{O}_2$
	Titanium orange/yellow	$(\text{Ti,Sb})\text{O}_2$
	Vanadium antimony titanium grey	$(\text{Ti,V,Sb})\text{O}_2$
Spinel pigments	Cobalt alumina blue	$\text{CoAl}_2\text{O}_4$
	Cobalt zinc blue	$(\text{Co,Zn})\text{Al}_2\text{O}_4$
	Cobalt chromium blue green	$\text{Co}(\text{Al,Cr})_2\text{O}_4$
	Cobalt chromite green	$\text{CoCr}_2\text{O}_4$
	Zinc iron brown	$\text{Zn}(\text{Fe,Cr})_2\text{O}_4$
	Iron chromium brown	$\text{Fe}(\text{Fe,Cr})_2\text{O}_4$
	Iron chromium manganese brown	$(\text{Fe,Mn})(\text{Fe,Cr,Mn})\text{O}_4$
	Copper chromite black	$\text{CuCr}_2\text{O}_4$
	Chromium cobalt iron black	$(\text{Co,Fe})(\text{Fe,Cr})_2\text{O}_4$
	Chromium zinc alumina pink	$\text{Zn}(\text{Al,Cr})_2\text{O}_4$
	Cobalt nickel zinc titanium green	$(\text{Co,Ni,Zn})_2\text{TiO}_4$
	Manganese iron black	$(\text{Fe,Mn})(\text{Fe,Mn})_2\text{O}_4$
	Chromium iron manganese zinc brown	$(\text{Zn,Fe,Mn})(\text{Fe,Cr,Mn})\text{O}_4$
	Iron titanium black	$\text{Fe}_2\text{TiO}_4$
	Cobalt tin blue	$\text{Co}_2\text{SnO}_4$
	Nickel iron brown	$\text{NiFe}_2\text{O}_4$
	Iron cobalt black	$(\text{Fe,Co})\text{Fe}_2\text{O}_4$
	Zinc iron brown	$(\text{Zn,Fe})\text{Fe}_2\text{O}_4$
	Chromium iron nickel black	$(\text{Ni,Fe})(\text{Cr,Fe})_2\text{O}_4$
	Chromium manganese zinc brown	$(\text{Zn,Mn})\text{Cr}_2\text{O}_4$
Chromium iron nickel black	$(\text{Ni,Mn})(\text{Cr,Fe})_2\text{O}_4$	
Zinc chromium cobalt aluminium blue	$(\text{Zn,Co})(\text{Cr,Al})_2\text{O}_4$	
Zircon pigments	Zirconium vanadium turquoise	$(\text{Zr,V})\text{SiO}_4$
	Zirconium praseodymium yellow	$(\text{Zr,Pr})\text{SiO}_4$
	Zirconium iron pink	$(\text{Zr,Fe})\text{SiO}_4$
	Zirconium silicon grey	$(\text{Zr,Fe})\text{SiO}_4$
Haematite/corundum pigments	Manganese alumina pink	$(\text{Mn,Al})_2\text{O}_3$
	Chromium alumina pink	$(\text{Cr,Al})_2\text{O}_3$
	Iron chromium black	$(\text{Fe,Cr})_2\text{O}_3$
	Chromium green	$\text{Cr}_2\text{O}_3$
	Iron haematite brown	$(\text{Fe,Cr})_2\text{O}_4$
Periclase	Cobalt nickel grey	$(\text{Co,Ni})\text{O}$
Phenacite	Cobalt zinc silicate blue	$(\text{Co,Zn})_2\text{SiO}_4$
Olivine	Cobalt silicate blue	$\text{Co}_2\text{SiO}_4$
Baddeleyite	Zirconium vanadium yellow	$(\text{Zr,V})\text{O}_2$
Cassiterite	Tin vanadium yellow	$(\text{Sn,V})\text{O}_2$
	Chromium tin orchid	$(\text{Sn,Cr})\text{O}_2$
	Tin antimony grey	$(\text{Sn,Sb})\text{O}_2$
Sphene	Chromium tin pink	$\text{CaO}:\text{SnO}_2:\text{SiO}_2:\text{Cr}_2\text{O}_3$
Garnet	Victoria green	$3\text{CaO}:\text{Cr}_2\text{O}_3:3\text{SiO}_2$
Pyrochlore	Lead antimony yellow	$\text{Pb}_2\text{Sb}_2\text{O}_7$

Table 6.2: Examples of existing Complex Inorganic Coloured (CIC) pigments

In the manufacture of rutile pigments, the rutile lattice of titanium dioxide absorbs nickel (II) oxide, chromium (III) oxide, manganese (II) oxide or vanadium (III) oxide as colouring components and antimony (V) oxide, niobium (III) oxide or tungsten (III) oxide (or other modifiers) to maintain an average cation valency of four, similar to titanium. Incorporation of these oxides in the inorganic complex colour pigment results in the loss of their chemical identity and consequently of their original chemical, physical and physiological properties. Therefore, these rutile pigments are not considered as, e.g. nickel, chromium or antimony compounds, but as titanium compounds. Most of these rutile pigments are clearly defined in terms of toxicity and environmental behaviour by their own CAS and EINECS number. The same can be said about the other CIC pigment systems.

The importance of CIC pigments is steadily growing due to their extremely high stability and their resistance to high temperatures.

#### 6.1.1.1.3 Zinc sulphide pigments and precipitated barium sulphate (blanc fixe)

**Zinc sulphide pigments (pure zinc sulphide and lithopone)** are pigments with very high whiteness. They are important speciality chemicals and find increasing application in paints and coatings as well as in plastics and synthetic fibres. Zinc sulphide is particularly suitable for incorporation in glass fibre reinforced plastics because it is significantly less hard than titanium dioxide. Zinc sulphide does not, therefore, damage the sensitive glass fibres embedded in the plastic. Final consumers are, e.g. the building, automotive and textile industries. Glass fibre reinforced plastics are used, *inter alia*, for the construction of high-tech sailing yachts, plastic car bodyshells and attractively styled sports equipment. Lithopone is a mixture of zinc sulphide and precipitated barium sulphate, also containing some zinc oxide.

High purity **precipitated barium sulphate** (also called 'blanc fixe') is used as a functional additive in paints and coatings, plastics and paper. In paints and coatings, it enhances the efficiency of coloured pigments by acting as a spacer between pigment particles; it is used, for example, in high quality top coats in the automotive industry. In powder coatings, it improves rheology as well as the mechanical performance parameters and permits optimum gloss values. Precisely defined particle sizes and geometries are the reason for many specialised uses of blanc fixe in plastic applications. In injection moulding, for instance, blanc fixe pigments facilitate the removal of the plastic component from the mould, while simultaneously enhancing the material's strength. In translucent plastic sheets, special blanc fixe grades ensure systematic light scattering. Used in paper production, blanc fixe has a beneficial effect on the paper's brightness and photostability leading to improved printing performances. As a contrast agent in medicine, high purity barium sulphate is used in the X-ray examination of the gastrointestinal tract.

#### 6.1.1.2 Toxicity

Due to their low solubility (in water as well as in acids and alkalis), inorganic pigments bioavailability and toxicity are very low.

Most inorganic pigments are respirable fine particulate matter and contain heavy metals, so precautions have to be taken to protect the health of the workers at the place of production.

Although some of the raw materials used for the manufacture of CIC pigments are classified as dangerous, during the calcination process at high temperatures (around 1200 °C) a reaction takes place that forms a new substance with an extremely low solubility in water as well as acids and bases, with physical, chemical and toxicological properties that are very different from the properties presented by the raw materials of origin. Chemical elements have been fixed inside a very stable crystalline structure. Therefore, for most of the CIC pigments, calcination at high temperatures acts as an inertisation process where the final product achieved presents no danger.

### 6.1.1.3 Speciality inorganic pigments production and consumption in Europe and worldwide

The formidable increase of manufactured coloured products has led to the significantly growing demand of colourants in the last few decades. As natural (mined) pigments have not been able to satisfy this demand, the production of inorganic pigments has steadily increased.

The 1995 worldwide production of inorganic pigments (including TiO<sub>2</sub> and carbon black) amounted to some five million tonnes for colouring purposes. The main producers are the US and Western Europe (each representing about 30 % of worldwide production).

The estimated worldwide production of inorganic pigments in 1995 is given in Table 6.3 (some of the volumes reported can vary depending on the information source).

Inorganic pigments	Production in kilotonnes/year	Market share in %
Titanium dioxide	3170	66
Iron oxides (natural and synthetic)	720	15
Carbon black	530	11
Lithopone and zinc sulphide	190	4
Chromate	145	3
Chromium (III) oxide	48	1
Zinc oxide	<48	<1
Molybdate	<48	<1
Luster pigments	<48	<1
Complex Inorganic Coloured (CIC) pigments	<48	<1
Iron blue	<24	<0.5
Ultramarine	<24	<0.5

**Table 6.3: Estimated worldwide production of inorganic pigments in 1995**

The largest manufacturer of synthetic iron oxide pigments worldwide is located in Germany, with an annual production of 300000 tonnes.

In 2002, the worldwide annual consumption of rutile pigments amounted to 30000 tonnes. The worldwide annual consumption of spinel and zircon pigments was about 20000 tonnes. The consumption of haematite/corundum based CIC pigments was estimated to be about 15000 tonnes.

In 2002, the world production of precipitated barium sulphate was about 150000 tonnes, of which 110000 tonnes were produced in Europe.

The exclusive worldwide producer of zinc sulphide pigments is located in Duisburg, Germany.

At the Duisburg plant, there is integrated production of zinc sulphide, barium sulphate and lithopone with a capacity of 20000 tonnes of zinc sulphide and 75000 tonnes of barium sulphate and lithopone (composed of a mixture of barium sulphate and zinc sulphide). As the production of lithopone was shifted to China (except for the production of specialities), the Duisburg plant focuses on the production of zinc sulphide and barium sulphate pigments.

It should be noted that the production of cadmium pigments has decreased strongly over the years, in part due to European legislation encouraging substitution. There is no production of these pigments in Germany, although production has been reported in France and the UK.

In Europe, a speciality inorganic pigments facility produces between a few tonnes and 100000 tonnes of pigments per year.

#### 6.1.1.4 Features of the European speciality inorganic pigments industry

In Europe, large enterprises (over 250 employees), medium sized enterprises (between 50 and 249 employees) and small companies (below 50 employees) manufacture speciality inorganic pigments. Within these companies, the workforce employed to run a pigments production facility is generally below 50. Production is carried out in small to large facilities using a continuous or a batch mode of operation. Production is carried out in standalone installations or in installations that are part of a larger chemical complex.

#### 6.1.1.5 Economics

The speciality inorganic pigments industry is a mature industry. Most processes have been developed and adapted over the past 200 years. Emerging competition from outside the EU makes further expansion of this industry within the EU difficult. Zinc sulphide, barium sulphate and the majority of lithopone pigments are already produced outside the EU.

### 6.1.2 Applied processes and techniques

Due to the large variety of inorganic pigment products, production processes have, in many cases, been developed individually using the specific know-how of individual companies. Naturally, this know-how is confidential and detailed information (e.g. concerning process conditions, raw materials and additives) is not reported herein. Nevertheless, the general manufacturing principles and techniques used to produce inorganic pigments are described in this section.

Although many production processes have been developed to manufacture the very large variety of inorganic pigments, production may be broken down into the following two main activities:

- pigment synthesis
- pigment processing.

Figure 6.1 shows the main steps in the synthesis and processing of inorganic pigments.

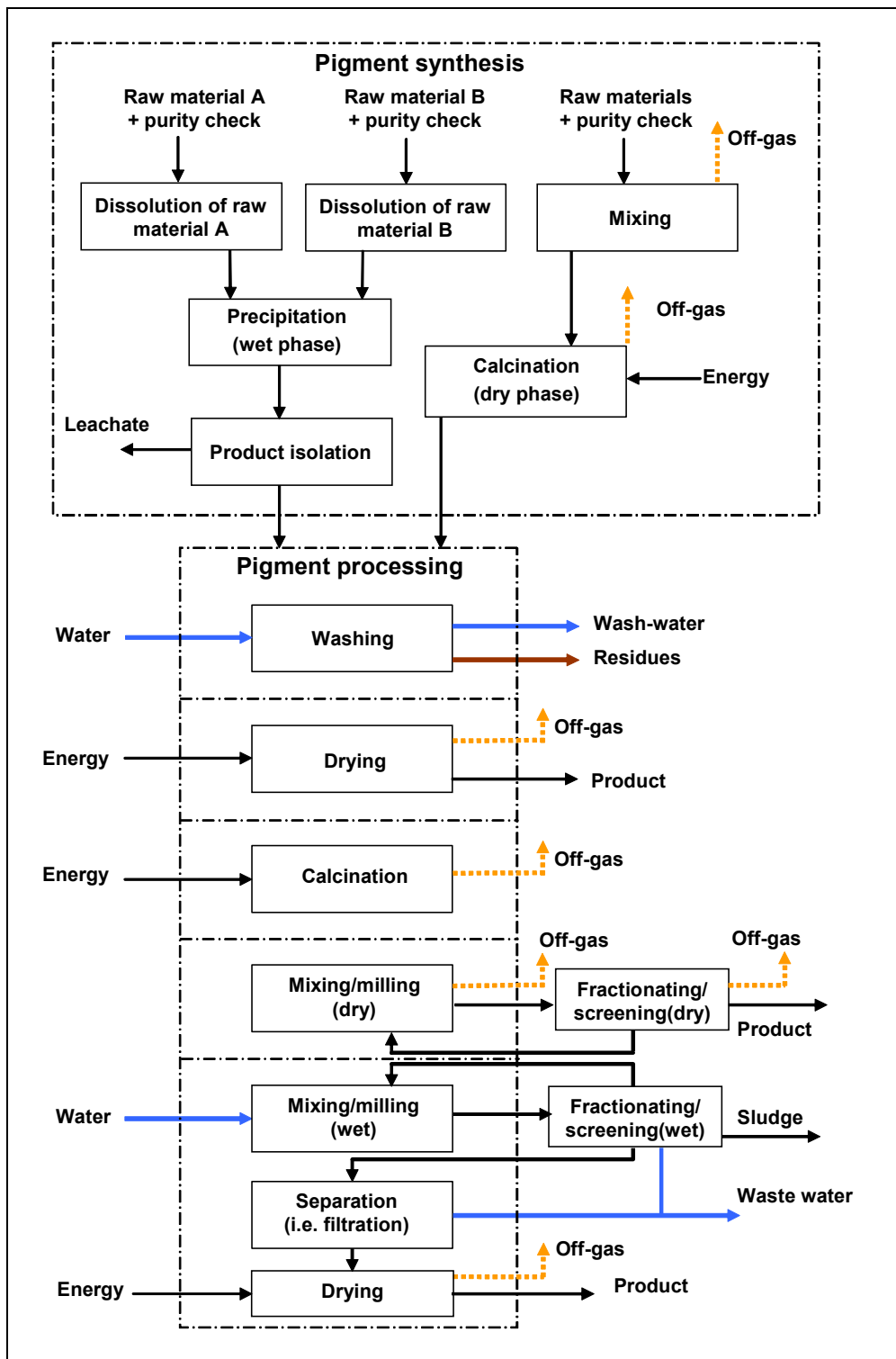

Figure 6.1: Pigment synthesis and processing

### 6.1.2.1 Pigment synthesis

There are two possible routes for pigment synthesis:

- the wet chemical process (wet route)
- the dry calcination process (dry route).

#### 6.1.2.1.1 Wet chemical process

The wet chemical process is based on a precipitation reaction of dissolved raw material substances followed by product isolation. After a sometimes necessary purification step (e.g. for the production of zinc sulphide pigments), the raw materials are individually dissolved in water, acid, alkaline or salt solutions. The solutions are then mixed together and led into a precipitation tank for reaction. The solubility of the reaction product is much lower than the solubility of the starting materials. After the reaction step, the product is dehydrated in chamber filter presses. The dehydration step causes a leachate containing some residues of the starting raw materials, by-products of the reaction (mainly salts) and, in some cases, also a dissolved share of the desired pigment product.

The wet chemical process is used when the raw materials are soluble, which is the case for metal sulphates, chlorides or hydroxides. In the case of oxides, which are sparingly soluble or insoluble, the dry calcination process is used instead.

In most technologies dissolving and/or precipitation of (pre)pigments need a given acidity/alkalinity of solution (optimal pH range). Consequently, the pH value of the waste water resulting from the production of inorganic pigments using a wet chemical process may have environmental importance.

#### 6.1.2.1.2 Dry calcination process

Calcination can be divided into **thermal decomposition/conversion** and **high temperature reaction**.

**In thermal decomposition/conversion**, the raw material is decomposed at high temperatures (between approximately 150 and 1300 °C), e.g. oxidation of iron sulphate with oxygen to form  $\text{Fe}_2\text{O}_3$  and  $\text{SO}_3$ . This process requires the strict monitoring of the temperature/time curve of the reaction.

**In the high temperature reaction**, the raw materials react with each other in a so-called solid phase reaction, which leads to the formation of the desired pigments. The reaction takes place at temperatures between 500 and 1400 °C, below the individual melting temperatures of the raw materials. The raw materials used are essentially metal oxides, hydroxides or carbonates, and only exceptionally other metal compounds. In some cases, mineralisers (such as sulphates, chlorides and fluorides) are used in minor amounts, which give rise to emissions of such substances into the air.

Gaseous reaction products leave the reaction chamber through the same emission point (not necessarily at the same time) as the off-gas in both thermal decomposition/conversion and high temperature reaction processes.

#### 6.1.2.1.3 Environmental impact of pigment synthesis

The wet chemical and the dry calcination processes have different environmental impacts.

The wet chemical process requires a large amount of water and produces a large amount of waste water, whereas the dry calcination process requires less water but more energy. In the wet chemical process, a reduction of emissions can mainly be obtained by suitable waste water treatment methods, while in dry calcination, environmental measures concentrate on the minimisation of off-gas emissions and energy use. Rarely can either of the two routes be used to manufacture the desired pigment product. The product quality specifications often impose the production route to use.

### 6.1.2.2 Pigment processing

The following process steps can be found in pigment processing:

- product **washing** for eliminating soluble by-products (e.g. salts)
- **drying** (after wet processing steps)
- **calcination** for restructuring the pigment particles
- **mixing/milling** for adapting the particle size (milling can be carried out through wet or dry processes) followed by **filtration/screening** and **drying** in the case of wet milling.

All these steps are not necessarily applied for producing every type of pigment; the choice of applying all or some of these steps depends on the following conditions:

- the required quality of the end-product
- the raw materials used
- the pigment synthesis process used (wet chemical process or dry calcination).

Regardless of which pigment synthesis process is used, in some cases pigments require a washing step in order to eliminate soluble salts. The washing step generates waste water heavily loaded with salts. After washing, pigments have to be thermally dried. The drying provokes off-gases and condensate residues. Because the very fine pigment particles fuse into larger units (known as aggregates, which, on cooling, flocculate to form agglomerates) in the outlet of the dryer, the product must be milled after the drying step in order to obtain the required very fine particle size. Dry milling may cause dust emissions.

Washing, drying and milling production steps are carried out for the production of pigments such as chromium yellow, molybdate orange, iron blue, cadmium yellow, bismuth vanadate and lead chromate as well as anti-corrosive pigments such as zinc potassium chromate, zinc or strontium chromate, zinc and chromium phosphate.

For the production of some pigments (e.g. cadmium pigments), an additional calcination step is required in order to restructure the pigment particles.

### 6.1.2.3 Measures for reduction of emissions

Without the necessity of analysing the processes of pigment manufacturing in more detail, the systematic classification of the possible processes described earlier already reveals the basic principles of waste gas and waste water treatment in the production of inorganic pigments.

#### 6.1.2.3.1 Principle of waste gas treatment

The main sources of exhaust gas emissions are kilns (rotary, chamber, tunnel kilns), as well as dryers and grinders (in the dry milling of pigments). Selection of a particular off-gas treatment depends on the off-gas constituents.

Table 6.4 gives examples of off-gas treatments depending on the pollutants contained in the off-gas.



Pollutant	Source	Pigment production	Off-gas treatment
Dust and heavy metals	Kiln Grinder (dry milling) Dryer	CIC pigments Chromium (III) oxide pigments Iron oxide pigments Zinc sulphide pigments	- cyclone - electrostatic precipitator - neutral or alkaline washing - fabric filter
SO <sub>2</sub>	Kiln	CIC pigments Chromium (III) oxide pigments Zinc sulphide pigments	- oxidation of SO <sub>2</sub> to SO <sub>3</sub> and washing to H <sub>2</sub> SO <sub>4</sub> - alkaline washing
NO <sub>x</sub>	Kiln	CIC pigments	
Fluoride	Kiln	CIC pigments (i.e. zircon pigments)	- lime washing
Organic compounds	Reactor	Iron oxides by the Laux process	- combustion - condensation (for high VOC concentration) - catalytic oxidation (for low VOC concentration)

**Table 6.4: Off-gas treatments for the production of inorganic pigments**

#### 6.1.2.3.1.1 Dust (including dust containing heavy metals)

Depending on the desired quality of the product, the required pigment particle size has to be between 0.01 and 30 µm, which generally causes dust containing heavy metal (most of the pigments produced contain heavy metals) emissions from the pigment production processes.

To reduce total dust emissions, off-gas streams from calcination kilns are led into a cyclone. In a second step, pigment producers mainly use other dry processes like fabric filters or electrostatic precipitators to further abate total dust (the treatment techniques chosen – fabric filters or electrostatic precipitators – largely depend on the temperature of the exhaust gases and the particle weight). The particulates abated can be recycled back into the process. Alternatively, washing can be used, which however, causes effluents, which have to be treated. Washing processes are preferred only in cases where other pollutants, besides dust, also have to be eliminated.

The calcination of pigments in ceramic saggars normally generates very low total dust levels and no additional off-gas treatment (besides the cyclone) is required. This is because saggars are very tightly stacked together in the kiln leaving a very small quantity of pigment powder in contact with the atmosphere of the kiln. Normally, natural gas is used as the energy source for the kiln and the dryer.

Figure 6.2 shows an off-gas treatment for reducing total dust from the exhaust gas of a dryer and from the exhaust gas resulting from a miller/grinder.

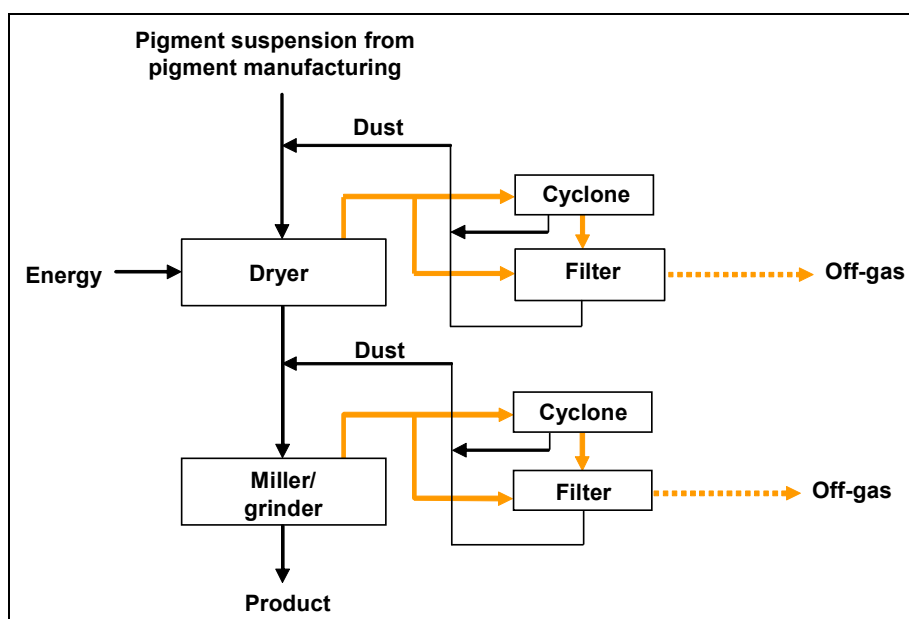

Figure 6.2: Off-gas treatment for reducing total dust from the exhaust gas of a dryer and a miller/grinder

#### 6.1.2.3.1.2 Sulphur dioxide (SO<sub>2</sub>)

Sulphur dioxide emissions are generated if sulphur is added as a reduction agent to the reaction process or as a raw material impurity (e.g. in the production of chromium (III) oxide pigments). Two different off-gas treatment methods are reported to be used in the production of inorganic pigments for the elimination of SO<sub>2</sub>:

- alkaline washing with caustic soda

when washing with caustic soda, SO<sub>2</sub> is converted into sodium sulphite. In some cases, hydrogen peroxide (H<sub>2</sub>O<sub>2</sub>) can be added to the effluent, in order to accelerate the generation of sodium sulphate:

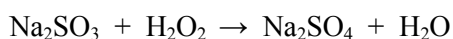
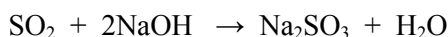

- conversion of SO<sub>2</sub> to SO<sub>3</sub> with subsequent H<sub>2</sub>SO<sub>4</sub> recovery

whereas the alkaline washing of the off-gas results in waste water, the oxidation of SO<sub>2</sub> to SO<sub>3</sub> results in the production of sulphuric acid, which can be recycled:

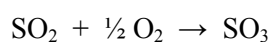

Another technique has been reported to be applicable:

- dry fluidisation using lime powder:

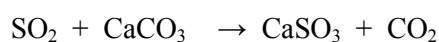

### 6.1.2.3.2 Principle of waste water treatment

In the production of inorganic pigments, waste water mainly originates from:

- off-gas scrubbing
- mother liquor
- washing of product (pigments)
- cleaning of vessels and floors.

Water effluents from the manufacture of inorganic pigments, mainly in the case of wet chemical processes, are loaded with the following pollutants:

- dissolved heavy metal compounds (e.g. lead, chromium, cobalt, copper, nickel cadmium, zinc)
- suspended pigments and insoluble by-products from the reaction (e.g.  $\text{Cr}(\text{OH})_3$ )
- alkaline salts of the used mineral acids
- single materials (depending on the production process) such as sulphides from the production of zinc sulphide pigments, nitrate and nitrite from the production of lead chromate, bismuth vanadate, cadmium pigments, and fluoride and vanadium from the production of zircon pigments.

Such compositions of the water effluent determines which waste water treatment to apply:

- concentration of waste water volumes (e.g. evaporation, drying)
- pretreatment, in the case of high pollutant loads with material recovery (by precipitation and flocculation) and recycling back into the pigment production
- treatment by single measures (e.g. chromium (VI) reduction)
- neutralisation and precipitation/flocculation of the total waste water.

Figure 6.3 shows a flow diagram of the treatment of water effluents (in certain cases a pretreatment is not necessary). As the production of pigments by wet chemical processes is usually discontinuous, leachates are led into a buffer tank before being treated.

In order to avoid resulting toxicity problems for fishes in complex chemical plants, effluents from certain production processes can be mixed with other less loaded effluents before being released to the receiving water (in the case of large SIC pigment installations) or before being discharged into municipal waste water treatment plants (in the case of smaller SIC pigment installations).

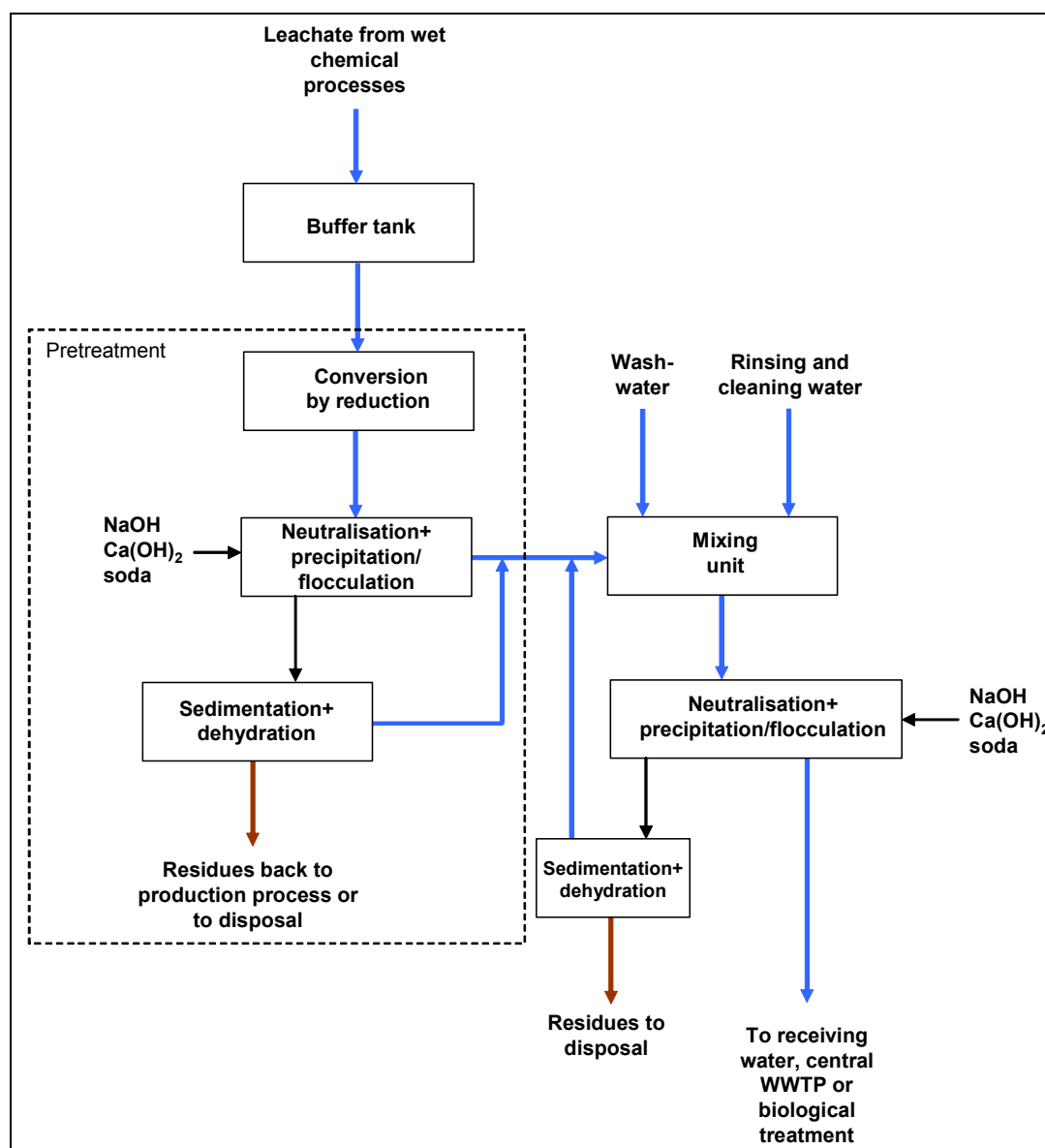

Figure 6.3: Flow diagram of water effluents treatment

In precipitation/flocculation, the pH value is adjusted by adding sodium hydroxide (NaOH), lime milk ( $\text{Ca}(\text{OH})_2$ ) or soda, and heavy metals are precipitated as hydroxides. After sedimentation and dehydration, filtration residues can be recycled back into the process when there is no adverse effect on pigment quality, e.g. in the manufacture of cadmium pigments, lithopone pigments, precipitated barium sulphate pigments, chromium oxide and iron oxide pigments. For lead chromate, recycling of sludge is not viable.

The pretreated effluents may be mixed with other water streams from the production process, (e.g. rinsing and cleaning water) and are led again to precipitation/flocculation, where the pH value is adjusted, in order to achieve an optimised separation of pollutants.

Solid residues are filtered, dehydrated, recycled back into the process or disposed of. Water effluents can be discharged to the receiving water or led into a central Waste Water Treatment Plant (WWTP) in the case of large production plants. A biological treatment for the elimination of organic traces is necessary for the Laux process in the manufacture of iron oxide pigments, a special process which is described in Section 6.1.2.4.2. The Laux process is reported to be used by only one company in Europe and by companies in India as a unique process. It therefore has no general validity. Biological treatment (denitrification) is also necessary for nitrate-loaded streams from the production of bismuth vanadate and lead chromate pigments.

Besides the treatment of water effluents, measures for reducing waste water volumes can be applied, such as:

- optimisation of washing processes by the multiple use of leachate in order to concentrate salts to facilitate disposal
- treatment methods used for dry waste gases.

If the waste gases are treated by scrubbing (because of the reliability and good cleaning results of scrubbers), the waste water generated by the scrubbing operation is treated as described above.

#### 6.1.2.4 Iron oxide pigments

Iron oxide pigments mainly consist of iron oxides or iron oxide hydroxides in different crystal modifications. Several chemical processes are used industrially in Europe for producing iron oxide pigments:

- precipitation process (yellow, red, orange and black pigments)
- Penniman-Zoph process (yellow, red, orange, and black pigments)
- Laux process (black, brown, yellow and red pigments).

Further information on the production of iron oxide pigments can be found in the LVIC-S BREF [24, European IPPC Bureau, 2004].

##### 6.1.2.4.1 Precipitation and Penniman-Zoph processes

By the oxidation of iron (II) sulphate solutions under certain reaction conditions and the use of certain germs, yellow, black and red pigments can be manufactured, the most important being the yellow pigments ( $\alpha$ -FeOOH).

Crystalline  $\alpha$ -FeOOH germs are very fine and can be used as transparent pigments. In order to obtain pigments with high hiding power, these germs have to grow to a certain size necessary for the hue. Either the precipitation process or the Penniman-Zoph process can be used to grow the pigment particles.

Aqueous oxidation processes generally have two phases:

- generation of defined germs
- growth to a certain particle size.

Figure 6.4 shows the steps of the aqueous oxidation processes.

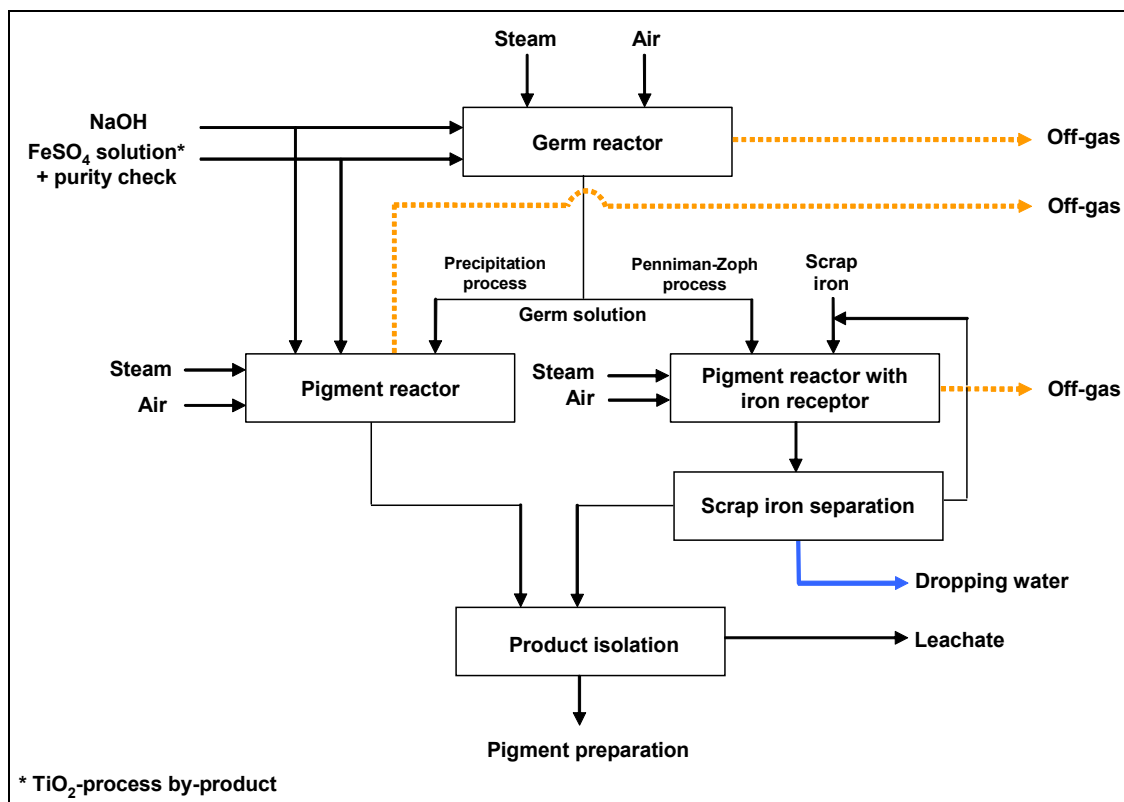
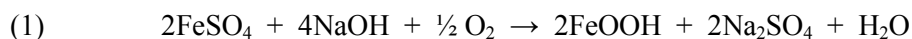

Figure 6.4: Wet processes for the production of iron oxide pigments and measures for the reduction of emissions

In the precipitation process, an iron (II) sulphate solution, sodium hydroxide and air are added for achieving the particle growth. Iron oxidation is carried out in a reactor at a temperature of about 70 °C with the addition of steam. The reaction equation is as follows:



The iron (II) sulphate solutions are residues coming from other industries, such as titanium dioxide production or liquor from the pickling of iron and steel. In order to ensure a stable product quality, these production residues can only be used if they do not contain colouring ions, such as manganese (II) or chromium (III), because of their adverse effect on the quality of the iron oxide pigments.

The Penniman-Zoph process (the most widely used production method for yellow iron oxide pigments) takes place by the addition of scrap iron, which is dissolved and oxidised with air in the pigment reactor without adding any other chemical substances. By defined rusting of the scrap iron, a pigment suspension with a slightly acidic pH value is obtained. The advantage of the Penniman-Zoph process in comparison to the precipitation process is that it considerably reduces the quantity of neutral salts (e.g.  $\text{Na}_2\text{SO}_4$ ,  $\text{NaCl}$ ) formed as by-products because the sulphuric acid generated by iron (II) sulphate hydrolysis-oxidation (reaction (3) below) reacts with the scrap iron to produce iron (II) sulphate (reaction (4) below):

Summarising reaction:

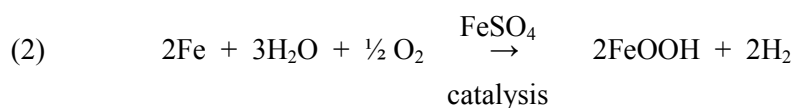

Basic reactions:

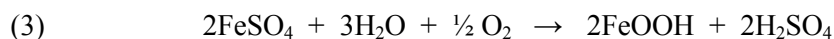

For accelerating the reaction, the temperature is kept stable at about 80 °C by adding steam. The air quantity has to be controlled to minimise the risk of explosions, but also to minimise emissions of heat and waste gas. One solution to achieve this is to operate above the temperature at which the vapour pressure of water is high enough to blanket the reactor's dome.

Scrap iron residues from other industries are used.

In the Penniman-Zoph process for the production of yellow iron oxide, different yellow hues may be obtained by variation of the process parameters (different germ size).

The same process can also be used for the manufacture of black iron oxide pigments. For the pigment growth, however, the precipitation process is preferred. For obtaining black pigments, iron (II) salt solutions are neutralised by adding alkali and is oxidised by the addition of air at temperatures of between 90 – 100 °C, up to the point where an iron (II)/iron (III) ratio of 0.5 ( $\text{Fe}_3\text{O}_4$ ) is obtained. Under suitable conditions for germ growth and after the complete oxidation, a similar process can also be used to produce very fine  $\alpha\text{-Fe}_2\text{O}_3$  germs necessary for easily dispersible  $\alpha\text{-Fe}_2\text{O}_3$  red pigments with a high colour strength.

The wet processes for the manufacture of iron oxide pigments as well as measures for the reduction of emissions are presented in Figure 6.5.

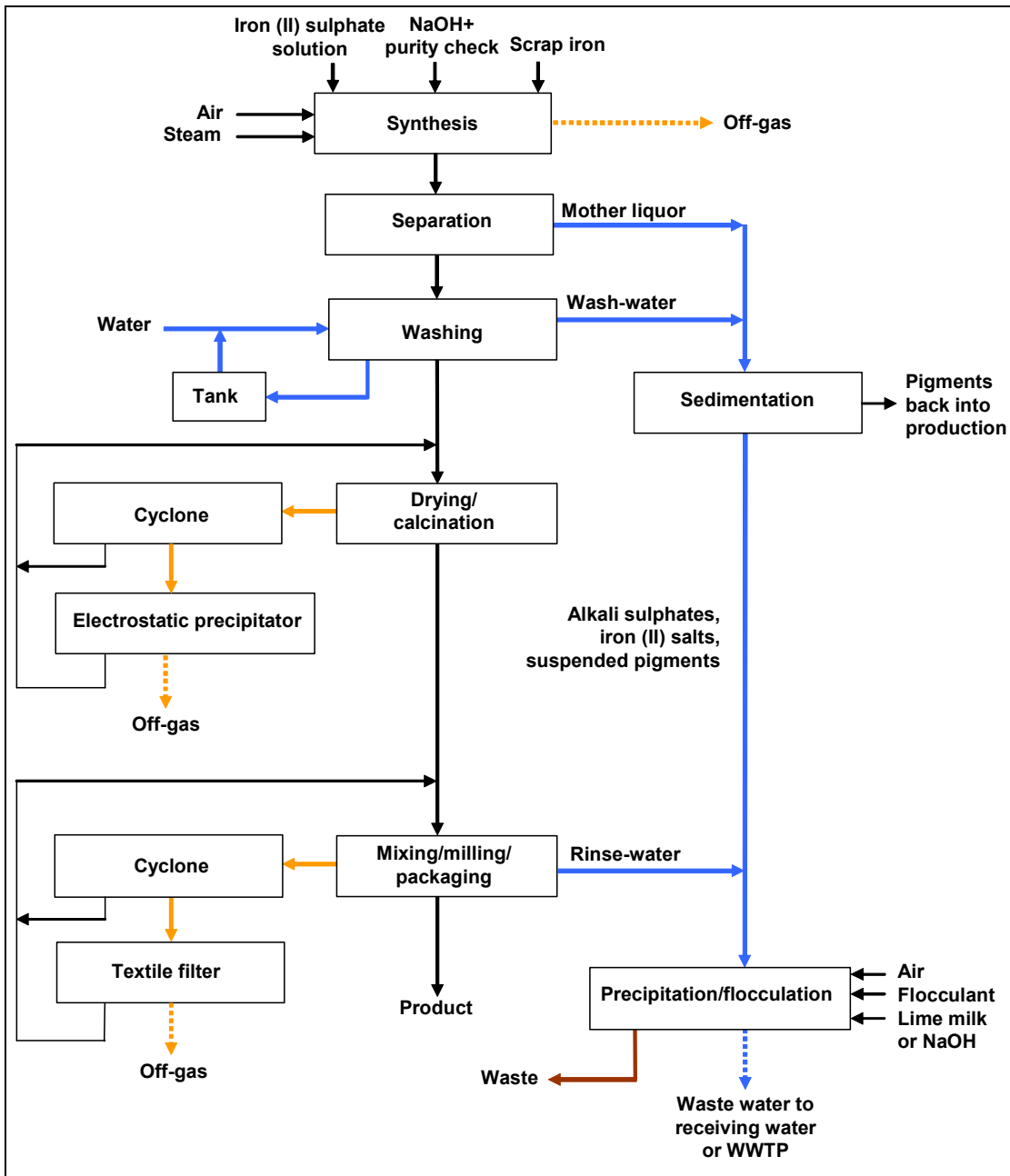

Figure 6.5: Process steps of aqueous oxidation processes in the production of iron oxide pigments

The pigment synthesis carried out by the precipitation process ( $\text{FeSO}_4$  solution and  $\text{NaOH}$ ) or the Penniman-Zoph process (scrap iron) is followed by pigment separation. As already described above, the pigments are washed, dried and, if necessary, calcined and milled.



#### 6.1.2.4.1.1 Waste gas treatment

Thermic process steps such as drying, calcination or dry milling are potential sources of dust emissions. In many cases, the first off-gas treatment takes place in cyclones, but their cleaning performance is generally not sufficient, because they can only separate coarse particles. Further off-gas treatments are selected according to different aspects. Due to the small size of the pigment particles, electrostatic precipitators or fabric filters have to be used. As fabric filters are easily jammed under humid conditions, electrostatic precipitators are often preferred for the cleaning of waste gas coming from dryers. In milling processes which cause an off-gas with a low humidity content, textile filters may be advantageous.

#### 6.1.2.4.1.2 Waste water treatment

As shown in Figure 6.5, water effluent streams consist of leachate, wash-water and rinse-water. Pigments insoluble in water are separated in a sedimentation basin and recycled back into production, when possible. Residual effluents from the precipitation process or the Penniman-Zohp process are quite different.

**In the precipitation process**, as revealed by reaction equation (1),  $\text{Na}_2\text{SO}_4$  is generated as a by-product. Residual  $\text{FeSO}_4$  is also discharged with the water effluents, so that the waste water contains high concentrations of salts and suspended solid materials.

**In the Penniman-Zoph process**, scrap iron is added and converted into the desired product by the addition of water and oxygen. In the chemical reaction, sulphuric acid is obtained as an interim product – equation (3) – which is immediately consumed – equation (4) –. Alkali salts are not added or generated in this process. Consequently, the effluents from the Penniman-Zoph process contain fewer salts than the waste water from the precipitation process.

For the Penniman-Zoph process, as well as for the precipitation process, the water effluent treatment consists of an oxidation step – to transform iron (II) to iron (III) by aeration with oxygen – followed by a precipitation/flocculation step (with the addition of a base and a soda as precipitation chemicals if necessary). In some cases, a defoaming agent and/or a flocculant are added into the waste water.

The iron (II) content can also be diminished in a neutralisation phase after the reaction step: an alkali solution and oxygen/air react with iron (II) to produce iron (III) oxide.

#### 6.1.2.4.2 Laux process

Another aqueous oxidation process for the production of iron oxide pigments is the Laux process, presented in Figure 6.6. By adding iron (II) chloride or aluminium chloride solutions, sulphuric acid and phosphoric acid (acting as catalysts), Laux modified the former aniline process (reduction of aromatic nitro compounds with metallic iron) to avoid unsuitable iron oxide residues and to yield high quality iron oxide pigments with a high colour strength.  $\text{Fe}_3\text{O}_4$  pigments can directly be used or can be converted further to high quality red pigments  $\alpha\text{-Fe}_2\text{O}_3$  by calcination. The addition of aluminum chloride (instead of iron (II) chloride) leads to the formation of high quality  $\alpha\text{-FeOOH}$  yellow pigments. Further addition of iron (II) or aluminum chloride solution and phosphoric acid can modify the properties of the iron oxide pigments.



The black pigments ( $\text{Fe}_3\text{O}_4$ ) and yellow pigments ( $\alpha\text{-FeOOH}$ ) are formed in the absence of bases, and nitrobenzene ( $\text{C}_6\text{H}_5\text{NO}_2$ ) is used as an oxidation agent. At the end of the reaction most of the aniline ( $\text{C}_6\text{H}_5\text{NH}_2$ ) is separated by condensation, the residue being distilled off by steam distillation. The waste gas from the condenser containing hydrogen and traces of aniline is led to a power plant for combustion.

The pigment in the reactor is a paste, which, besides  $\text{FeCl}_2$ , also contains residual iron. Excess iron chips are separated from the pigment in a classifier. They can be re-used in the cement/steel industry or have to be disposed of. After iron separation, the pigment paste is washed and directed, free of salts, into thickeners and then into rotary vacuum filters. While aniline containing leachates from the thickeners are fed into the central waste water treatment plant, the wash-water from filtration is led to the central waste water precipitation plant.

Depending on the desired product, the pigment paste is subsequently dried and ground (black or yellow pigments) or calcined in a rotary kiln and ground (red pigments). The waste gas from the dryer and the rotary kiln is led over cyclones for total dust separation and further on into electrostatic precipitators.

### 6.1.2.5 Chromium (III) oxide pigments

A plant in Germany produces chromium oxides in a solid state process. The manufacturing process and the subsequent pigment preparation processes are shown in Figure 6.7.

In this solid state process, sodium dichromate ( $\text{Na}_2\text{Cr}_2\text{O}_7$ ) is reduced with sulphur by intensively mixing the components and subsequent calcination in a rotary disc kiln at 800 to 1000 °C.

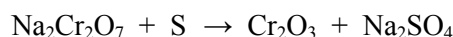

The calcination by-product is sodium sulphate. The reaction generates  $\text{SO}_2$  emissions.

After the reaction, water-soluble salts are separated off by washing-filtration. The product is then dried, ground and finally packed for transportation.

Sodium dichromate raw material is produced together with sodium chromate by a process in which ground chrome ore and soda ash are mixed (lime and/or leached calcine are sometimes added as well), roasted in an oxidising atmosphere, and leached with weak chromate liquor or water. The impure sodium chromate resulting from these operations is further neutralised, filtered and converted to sodium dichromate.

#### 6.1.2.5.1 Waste gas treatment

The main waste gas emission sources stem from the mixing step, the rotary disc kiln, the drying step and the milling of the product. The dust-loaded off-gas from the mixing is purified by a washer, which causes waste water charged with the pollutants removed from the waste gas.

The waste gas from the rotary disc kiln is mainly loaded with dust, heavy metals and sulphur dioxide. The waste gas is purified from its total dust content in a washer where the abating water used is the spent water of the previous washer (see Figure 6.7).  $\text{SO}_2$  is oxidised to  $\text{SO}_3$ , the latter being converted in a washer to 10 – 20 % sulphuric acid by the addition of water. The obtained washing liquor is used for the waste water acidification before the reduction of chromate.

Waste gas streams from the dryer and the milling process are treated in the off-gas treatments for separation as described above.

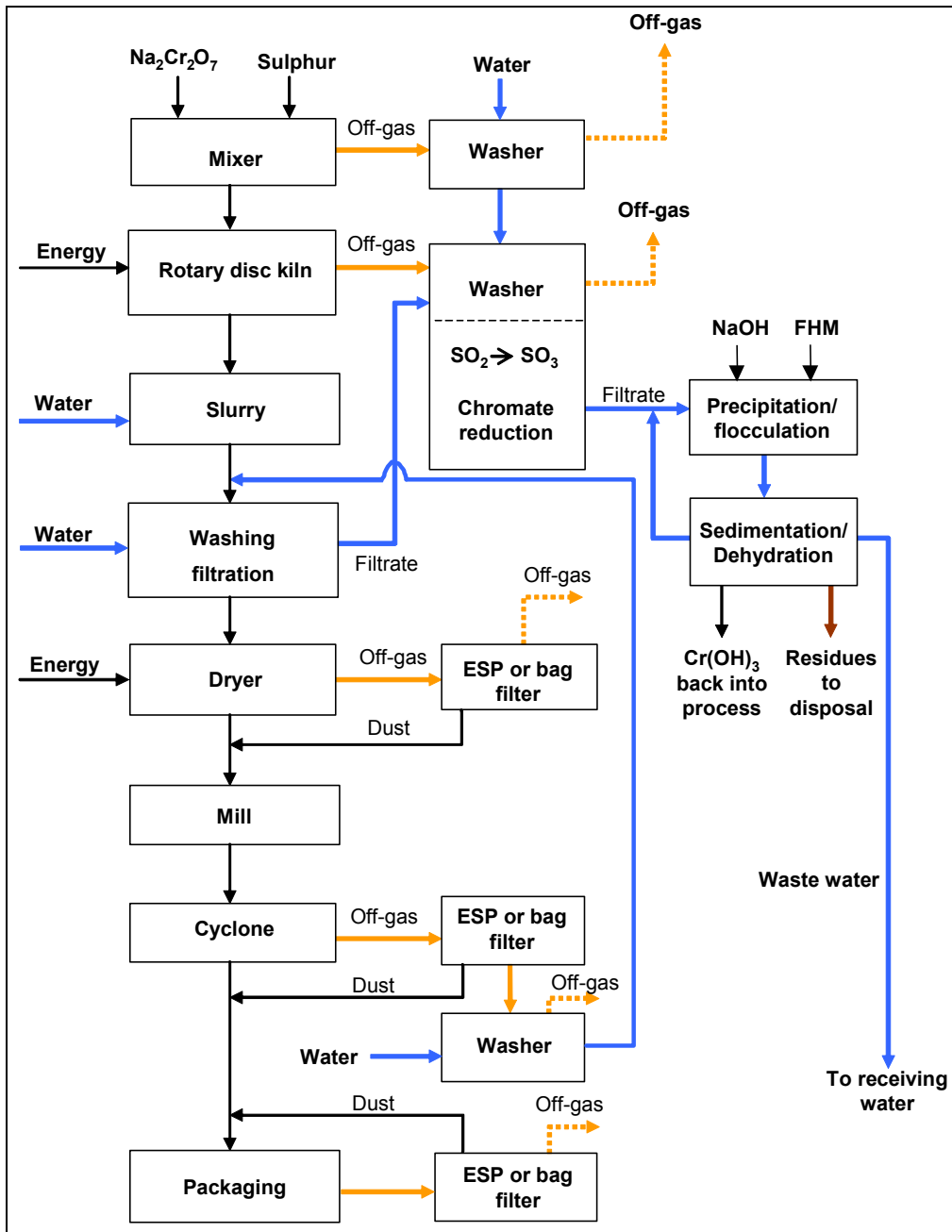

Figure 6.7: Production of chromium (III) oxide pigments

### 6.1.2.5.2 Waste water treatment

The main water effluent streams and their composition are summarised in Table 6.5.

Process step	Effluent source	Pollutants
Mixing	Wash-water from off-gas washer	Sodium dichromate
Product washing	Wash-water	Sodium sulphate Sodium dichromate Suspended pigments
Mixing/milling, packaging	Rinse-water	Suspended pigments

**Table 6.5: Main water effluent streams for the production of chromium(III) oxide pigments**

Chromium (VI) has to be separated from the waste water. Consequently, unreacted sodium dichromate is reduced first to chromium (III) by the addition of sulphur dioxide or sodium hydrogen sulphite. A slight excess of the reduction agent is dosed in order to yield a complete reaction. This causes a sulphite load and a COD in the waste water. The chromate reduction is carried out under slightly acidic conditions. In order to obtain the necessary pH value, sulphuric acid obtained from waste gas treatment of the calcination is added.

After the chromate reduction, chromium (III) is precipitated with a sodium base as chromium hydroxide by the addition of flocculation agents (FHM). The sediment is mechanically dehydrated and recycled back into the process.

Together with other effluent streams, the total waste water from the chromium (III) oxide pigment production is purified again in a precipitation step and then discharged into the receiving water. The specific water demand is about 60 m<sup>3</sup>/t of pigments produced.

### 6.1.2.5.3 Waste

The chromium hydroxides obtained in the precipitation after the chromate reduction are recovered and recycled back into the process. Other residues from the precipitation step have to be discharged into a suitable disposal site.

### 6.1.2.6 Complex Inorganic Coloured (CIC) pigments

The manufacture of complex inorganic coloured pigments is presented in a flow diagram in Figure 6.8.

The production process of rutile and spinel pigments consists of a reaction of fine metal oxides, hydroxides or carbonates at temperatures of between 800 and 1400 °C. The reaction process is accelerated by the selection of finely dispersed reaction materials. The starting materials in the manufacture of CIC pigments are weighed, intimately mixed and calcined either in a rotary or tunnel kiln (continuously) or in a chamber kiln (discontinuously). After the calcination process, the clinker obtained needs, in some cases, to be purified from soluble substances by intensive wet grinding, then dried and, if necessary, milled again.

#### 6.1.2.6.1 Waste gas treatment

The manufacture of rutile pigments requires reactive anatase or titanium dioxide hydrolysate containing chemically bound sulphuric acid. For the oxidation of antimony, air is led into the calcination process. Waste gas leaving the combustion process is purified from raw material dust particles and other gases (e.g. SO<sub>2</sub>, NO<sub>x</sub>) by particle separators and other off-gas treatments. The dust recuperated can often be recycled back into the process. Fluoride contained in the off-gases from the synthesis of zirconium silicate pigments could be removed by lime washing.

6.1.2.6.2 Waste water treatment

The volume and content of pollutants of the water effluents resulting from the production process depend on the pigments produced. Water effluents contain dissolved neutral salts and suspended solid materials (oxides and pigments). The suspended solid materials are treated by flocculation and are separated from the waste water. Solid residues per tonne of pigment product are quite small (see Section 6.1.3.1.3 below).

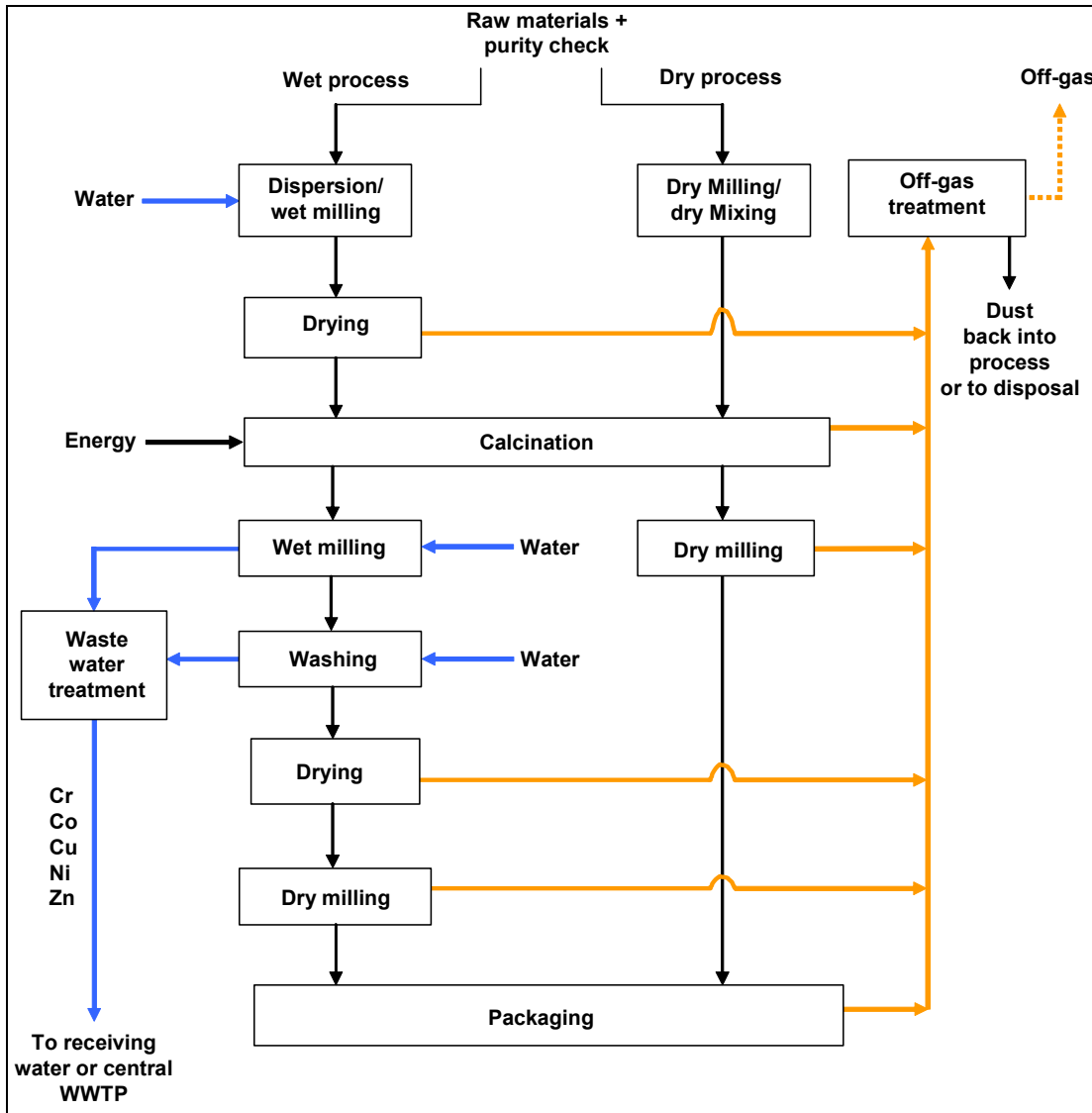

Figure 6.8: Production of Complex Inorganic Coloured (CIC) pigments

### 6.1.2.7 Zinc sulphide, barium sulphate and lithopone pigments

#### 6.1.2.7.1 Zinc sulphide and lithopone pigments

The processes used to produce zinc sulphide and lithopone (composed of a mixture of barium sulphate and zinc sulphide) pigments are very similar and closely connected to the processes used to produce barium sulphate pigments (the sodium sulphide by-product of barium sulphate precipitation is used in zinc sulphide precipitation). Additionally, a close connection exists in the field of waste water treatment. Figure 6.9 shows a flow diagram for the production of lithopone pigments.

Zinc sulphide pigments are produced from zinc sulphate and sodium sulphide in accordance with the following equation:

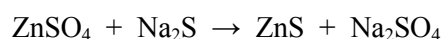

Lithopone is produced by precipitation of zinc sulphate with barium sulphide:

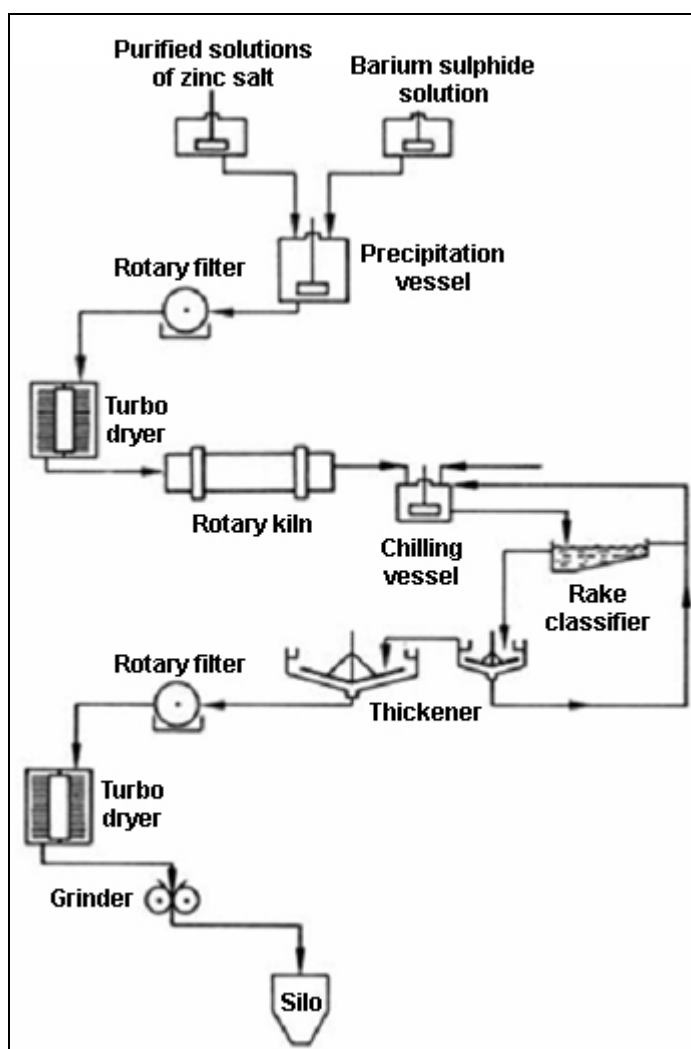
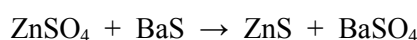

Figure 6.9: Flow diagram for the production of lithopone pigments [1, Ullmann, 2001]

For the production of zinc sulphide and lithopone pigments, raw zinc salt solutions (zinc leachates) obtained from other companies are used.

The source of zinc can be zinc oxide from a smelter, zinc dross or sweepings, ammonium chloride slag from hot dip galvanising, or liquid waste such as pickle liquors from galvanising plants. The main source of zinc sulphate solutions is from electrolysis and the production of zinc scrap and zinc oxide [1, Ullmann, 2001].

The solutions of zinc salts containing impurities need to be purified. The first stage of purification consists of chlorination. Iron and manganese are precipitated as oxide-hydroxides, and cobalt, nickel, and cadmium as hydroxides. Subsequently, the solutions are mixed with zinc dust at 80 °C (cementation). All the elements more noble than zinc (e.g. cadmium, nickel, cobalt, copper) are almost completely precipitated, while zinc develops into a solution. The zinc sludge is filtered off and taken to copper smelters for recovery of the noble metal components (second purification stage). Afterwards, the purified zinc sulphate solution is converted with sodium sulphide whereby zinc sulphide and sodium sulphate are formed. In the case of lithopone, barium sulphide is used instead of sodium sulphide. The sodium sulphide applied is a by-product of the production of barium sulphate which is made of barium sulphide and sodium sulphate.

The further preparation of zinc sulphide pigments and lithopone is identical. In order to achieve the required pigment properties, the precipitated product is drained, dried and calcined.

The hot product is then quenched in water, sedimented, dried, ground and packed for transportation.

### 6.1.2.7.1.1 Waste gas treatment

The main waste gas sources are from the thermic processes: drying and calcining of the pigments. Both processes are emission sources of dust, heavy metals and sulphur dioxide.

The waste gases are purified in a two-step gas cleaning system. In the first step, dust is washed out with water; the pigment is recovered by sedimentation and recycled back into production. In the second step, sulphur dioxide reacts with the zinc oxide suspension, a zinc sulphite solution is formed, which is re-used as a starting material for the production of zinc sulphate.

### 6.1.2.7.1.2 Solid by-products

The solids, containing iron and manganese, which precipitate during the first purification step of the zinc leachate, are recycled externally.

The metal sludges, produced during cementation, are supplied to zinc smelteries.

### 6.1.2.7.2 Precipitated barium sulphate pigments

Starting materials are natural barites with a barium sulphate content of more than 90 %.

Barites are reduced to water soluble barium sulphide by reaction with coke:

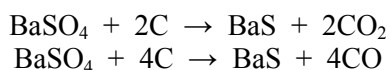

The by-products are carbon dioxide and sulphur dioxide. As there is a small excess of oxygen in the reaction, carbon monoxide is readily transformed to carbon dioxide.

The barium sulphide is leached in water and purified by separation and filtration.



The largest amount of barium sulphate is obtained by precipitation of barium sulphide with sodium sulphate:

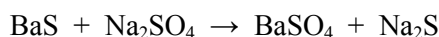

The sodium sulphide by-product may be used in different ways: it can be concentrated and used as a dehairing agent in the leather industry or it can be used as an intermediate for the production of inorganic and organic sulphides. In some cases, it is transformed to hydrogen sulphide and used in the Claus process for the production of sulphur.

In a plant in Germany, sodium sulphide is mainly used for the precipitation of zinc sulphide. Excess amounts are transformed to hydrogen sulphide, which is converted into sulphuric acid at a nearby sulphuric acid plant.

Special barium sulphate is generally produced by the reaction of barium chloride with sodium sulphate:

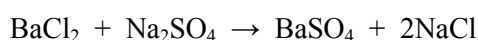

Barium chloride is obtained by the reaction of barium sulphide with hydrochloric acid. The hydrogen sulphide generated is also converted into sulphuric acid.

The precipitated barium sulphate is then isolated by filtration or separation, purified by intensive washing with water, dried and ground.

According to the different applications, inorganic and organic treatment is necessary either before or after drying.

#### 6.1.2.7.2.1 Waste gas treatment

The waste gases from the production of barium sulphide contain dust, heavy metals and sulphur dioxide.

Dust and heavy metals are removed by electrostatic precipitators. At the Sachtleben plant, the elimination of sulphur dioxide is carried out in a two step reaction: first sulphur dioxide is absorbed in cold polyglycolic ether; second, the waste gas is desorbed at elevated temperatures and led to the production of sulphuric acid.

Waste gas of the barium sulphate drying process only contains dust which is washed out with water and recycled back into the production process.

#### 6.1.2.7.2.2 Solid residues

The amount of solid residues remaining from the barium sulphide leaching and purification significantly depends on the quality of the natural barites used. The solid residues contain insoluble barium compounds, silica and carbon. They are dewatered and sent to landfill.

### 6.1.2.7.3 Waste water treatment

The production of zinc sulphide and barium sulphate pigments is an integrated process, which is tightly combined when considering waste water treatment.

Waste water, containing zinc salts from the production of zinc sulphide pigments, is treated with sodium sulphide solution. Waste water, containing sulphide from the production of barium sulphate, is treated with zinc salt solution.

In both cases, insoluble zinc sulphide precipitates and is recycled back into the production process.

Possibly dissolved barium salt is precipitated with sodium sulphate and recycled back into the production process.

As all solids arising from the process are recycled back into production, the waste water treatment works without any solid waste production.

For the production of zinc sulphide, lithopone and barium sulphate pigments, the different sources of waste water are listed in Table 6.6 together with their main pollutants.

Process step	Type of waste water	Pollutants
Draining of preliminary products	Filtrate water	Sodium chloride Sodium sulphate Suspended pigments
Drying of preliminary products	Off-gas scrubbing water	Suspended solids
Thermic process	Off-gas scrubbing water	Suspended pigments Sulphite
Washing and draining of finished products	Filtrate water	Solved zinc Suspended pigments
Drying of finished products	Off-gas scrubbing water	Suspended pigments
Purification of production lines	Rinsing and purification water	Suspended pigments

**Table 6.6: Sources of waste water from the production of zinc sulphide, lithopone and barium sulphate pigments**

## 6.1.3 Consumption and emission levels

### 6.1.3.1 Raw materials, auxiliary chemicals, energy and water consumption

#### 6.1.3.1.1 Energy consumption

Energy consumption depends on the chemical process used, the technology used, as well as market needs and availability of energy sources such as natural gas as a clean energy source.

Table 6.7 provides some examples for the consumption of energy in the production of SIC pigments.

Example plants	Type of pigments produced	Electricity consumption	Heat consumption	Main source(s) of energy use
		MWh/yr/t of pigments	MWh/yr/t of pigments	
F <sup>1</sup>	• Zinc sulphide	5.74		<ul style="list-style-type: none"> <li>• Calcination in electric furnace</li> <li>• Drying</li> </ul>
G <sup>1</sup>	• Strontium aluminates	39.07		<ul style="list-style-type: none"> <li>• Calcination in electric furnace</li> <li>• Milling in ball mills</li> <li>• Sieving with standard mesh</li> </ul>
H <sup>2</sup>	• CIC	1	6.54	<ul style="list-style-type: none"> <li>• Calcination in intermittent kilns</li> <li>• Drying</li> </ul>
<sup>1</sup> TWG comment <sup>2</sup> TWG comment				

**Table 6.7: Consumption of energy at several plants producing SIC pigments in Europe**

#### 6.1.3.1.2 Air emissions

Concentration levels of pollutants measured in the off-gas after treatment at several plants in Europe are given in Table 6.8. The levels given are based on daily average values and data from a few months up to one year.

Example plants	Type of pigments produced	Total dust	Cr	Fluorides	Pb	NH <sub>3</sub>	NO <sub>x</sub>	SO <sub>2</sub>	VOCs	Zn	Source(s) of off-gas	Off-gas treatment(s) <sup>i</sup>
A <sup>1</sup>	• Bismuth vanadate • Lead chromate	1.2	0.109		0.513						• Drying <sup>a</sup> • Milling <sup>b</sup> • Product handling <sup>b</sup>	<sup>a</sup> • Wet scrubber <sup>b</sup> • Fabric filters
C <sup>1</sup>	• Iron oxide • Lead chromate • CIC	<3 <sup>b</sup> <1.5 <sup>b</sup> <1.5 <sup>b</sup>					<20 <sup>a</sup>	<16 <sup>a</sup>				<sup>a</sup> • Wet scrubbers <sup>b</sup> • Fabric filters • Dust disposed of
D <sup>1</sup>	• Iron oxide <sup>a</sup> • Chromium oxide <sup>b</sup>	<20 <sup>4a</sup> <5 <sup>4b</sup>					<100 <sup>4</sup>				• Drying	<sup>a</sup> • Fabric filters <sup>a</sup> • ESP <sup>b</sup> • Fabric filters
F <sup>2</sup>	• Zinc sulphide	50.78				0.16	0	0	0	11.75	• Raw materials weighting and mixing <sup>b</sup> • Calcination <sup>a</sup> • Drying <sup>b</sup>	<sup>a</sup> • Wet scrubber (alkaline) <sup>b</sup> • Fabric filter
G <sup>2</sup>	• Strontium aluminates	2.2				0	0	0	56	0	• Raw materials weighting and mixing <sup>b</sup> • Calcination <sup>b</sup> • Milling <sup>b</sup> • Sieving <sup>b</sup>	<sup>b</sup> • Fabric filter
H <sup>3</sup>	• CIC	2 – 4 <sup>ab</sup>		0.2 – 2 <sup>c</sup>			32 – 65				• Raw materials weighting and mixing <sup>ab</sup> • Calcination <sup>abc</sup> • Grinding <sup>b</sup> • Drying <sup>b</sup>	<sup>a</sup> • Cyclone <sup>b</sup> • Fabric filter <sup>c</sup> • Fabric filter and lime waching

The values indicated in this table are daily average values in mg/Nm<sup>3</sup>.

<sup>1</sup> TWG comments  
<sup>2</sup> TWG comment  
<sup>3</sup> TWG comment  
<sup>4</sup> limit set in the permit  
<sup>i</sup> To avoid the generation of waste water, dry treatment methods for waste gas are favoured [39, Karschunke, 2004]  
<sup>a</sup>, <sup>b</sup> or <sup>c</sup> refer to the off-gas treatment(s) mentioned on the same line in the last column of the table

Table 6.8: Concentration levels of pollutants measured in the off-gas after treatment at several plants producing pigments in Europe

#### 6.1.3.1.2.1 Iron oxide pigments

In the precipitation and Penniman Zoph processes, emissions of dust and heavy metals are minimised by using cyclones and electrostatic precipitators (or fabric filters).

In the Laux process, hydrogen is produced in the reactor. The off-gas containing hydrogen, which is loaded with traces of aniline, is disposed of by combustion in a central power plant. The waste gas from the dryer and/or the calcination kiln is mainly loaded with dust, and is treated in cyclones and electrostatic precipitators.

#### 6.1.3.1.2.2 CIC pigments

In general, for the removal of total dust arising from the production of CIC pigments, an electrostatic precipitator or a bag filter is used in conjunction, where appropriate, with a dry or semi-dry acid gas scrubbing system. The emission level reported to be achieved with these techniques is  $<1.5 - 30 \text{ mg/Nm}^3$  [21, European IPPC Bureau, 2003].

The maximum value for  $\text{NO}_x$  emissions is considered to be  $400 \text{ mg/Nm}^3$  at the  $\text{O}_2$  percentage existing in the off-gas. The above given emission levels are peak levels and do not represent the average level over the entire calcination process, as the majority of pigment production is discontinuous.

For fluoride (where applicable), the maximum values are about  $5 \text{ mg/Nm}^3$ .

The maximum value for  $\text{SO}_2$  is  $500 \text{ mg/Nm}^3$  at the  $\text{O}_2$  percentage exiting in the off-gas using natural gas as fuel.

#### 6.1.3.1.3 Water consumption and emission

The techniques used to treat waste water at several plants producing pigments in Europe are presented in Table 6.9.

Concentration levels of pollutants measured in the waste water after treatment at several plants in Europe is given in Table 6.10.

When the WWTP is operated by an external company, the operator charges its clients (e.g. the SIC producer) according to their load (e.g. COD, N, P) – the conditions are fixed in a service provider contract. This entails a precise monitoring of the effluents coming in the WWTP and leads an efficient waste water treatment.

Example plants and type of pigments produced		Source(s) of waste water	Waste water treatment(s)
A <sup>1</sup>	<ul style="list-style-type: none"> <li>• Bismuth vanadate</li> <li>• Lead chromate</li> </ul>	<ul style="list-style-type: none"> <li>• Precipitation of pigments</li> <li>• Washing of pigments</li> <li>• Scrubbing of off-gases</li> </ul>	<ul style="list-style-type: none"> <li>• Precipitation, flocculation, sedimentation, sand filtration</li> <li>• Additional effluent filtration with fabric cartridges (<math>\leq 50 \mu\text{m}</math>)</li> <li>• Final biological treatment in municipal WWTP</li> <li>• Dewatering of sludge by filter press and disposal as hazardous waste</li> </ul>
C <sup>1</sup>	<ul style="list-style-type: none"> <li>• Lead chromate</li> <li>• Bismuth vanadate</li> <li>• Ceramic pigments</li> </ul>	<ul style="list-style-type: none"> <li>• Air scrubbing in wet or hot process steps like dissolution, oxidation of pigments/materials</li> <li>• Mother liquor</li> <li>• Washing of pigments</li> <li>• Cleaning of vessels and floors</li> </ul>	<p><u>Pretreatment of high-loaded streams (Pb, Sb):</u></p> <ul style="list-style-type: none"> <li>• Flow balancing</li> <li>• Precipitation, flocculation, sedimentation</li> <li>• Dewatering of sludge by filter press</li> <li>• The effluent from pretreatment is directed to the neutralisation step of the general waste water treatment</li> </ul> <p><u>General waste water treatment:</u></p> <ul style="list-style-type: none"> <li>• Flow balancing</li> <li>• Reduction</li> <li>• Neutralisation (multistage)</li> <li>• Precipitation/flocculation</li> <li>• Sedimentation</li> <li>• Filtration</li> <li>• Sludge is dewatered in a filter press and disposed of</li> <li>• Filtrate from dewatering or concentrate from backwash is led back to neutralisation</li> </ul> <p><u>Biological treatment (denitrification) for nitrate-loaded streams from the production of bismuth vanadate (350 kg/t) and lead chromate (90 kg/t):</u></p> <ul style="list-style-type: none"> <li>• Some metals have to be removed prior to denitrification to prevent contamination of activated sludge</li> <li>• Methanol, ethanol or sugar solutions are used as carbon nutrient sources</li> <li>• Flow balancing</li> <li>• First reaction stage</li> <li>• Second reaction stage</li> <li>• Separation (sludge is returned to the first reaction tank)</li> </ul>
C <sup>1</sup>	<ul style="list-style-type: none"> <li>• Iron oxide</li> <li>• Lead chromate</li> <li>• CIC</li> </ul>		<ul style="list-style-type: none"> <li>• The effluent is discharged to a municipal waste water treatment plant</li> <li>• Iron oxide sludge from waste water treatment is recycled back to the process</li> </ul>
D <sup>1</sup>	<ul style="list-style-type: none"> <li>• Iron oxide</li> <li>• Chromium oxide</li> </ul>	<ul style="list-style-type: none"> <li>• Filtration</li> <li>• Cleaning of vessels and floors</li> </ul>	<p><u>Pretreatment of high-loaded streams (<math>\text{Cr}_{\text{total}} \geq 10 \text{ mg/l}</math>):</u></p> <ul style="list-style-type: none"> <li>• Flow balancing</li> <li>• Reduction of Cr(VI) to Cr(III) by sulphite</li> <li>• Precipitation</li> </ul>

Example plants and type of pigments produced		Source(s) of waste water	Waste water treatment(s)
			<ul style="list-style-type: none"> <li>• Flocculation</li> <li>• Separation</li> <li>• Flow balancing</li> </ul> <ul style="list-style-type: none"> <li>• The pretreated waste water and the waste water with <math>Cr_{total} &lt; 10</math> mg/l (small amounts only) is sent directly to the central WWTP</li> <li>• Chromium hydroxide resulting from precipitation is recycled back into the process</li> <li>• Products not under specifications and dust from filters/scrubbers are also recycled back into the process</li> </ul>
F and G <sup>2</sup>	<ul style="list-style-type: none"> <li>• Zinc sulphide</li> <li>• Strontium aluminates</li> </ul>	<ul style="list-style-type: none"> <li>• Washing of pigments</li> <li>• Scrubbing of off-gases</li> <li>• Cleaning of floors</li> </ul>	<p>The liquid effluents generated in the production of strontium aluminates (plant G) are treated together with liquid effluents generated in zinc sulphide production (plant F) in a WWTP located in plant F. The following steps are carried out:</p> <ul style="list-style-type: none"> <li>• Sedimentation</li> <li>• Precipitation</li> <li>• Filter press</li> <li>• Neutralisation</li> </ul> <p>After this treatment, the liquid effluents are then discharged into a municipal drainage system that transfer it to a municipal WWTP for final treatment.</p>
H <sup>3</sup>	<ul style="list-style-type: none"> <li>• CIC</li> </ul>	<ul style="list-style-type: none"> <li>• Washing of pigments <sup>a</sup></li> <li>• Wet grinding <sup>b</sup></li> <li>• Cleaning of floors and installations <sup>c</sup></li> </ul>	<ul style="list-style-type: none"> <li><sup>a</sup> • Evaporation/concentration</li> <li><sup>bc</sup> • Sedimentation</li> <li><sup>bc</sup> • Precipitation</li> </ul>
<sup>1</sup> TWG comments; <sup>2</sup> TWG comments; <sup>3</sup> TWG comments <sup>a</sup> , <sup>b</sup> or <sup>c</sup> refer to the waste water treatment(s) mentioned on the same line in the last column of the table			

Table 6.9: Techniques used to treat waste water at several plants producing pigments in Europe

Example plant	Waste water volume treated	Type of discharge to receiving water	BOD <sub>5</sub>	COD	TOC	TSS	Al	Cd	Chlorides	Cr <sub>total</sub>	Co	Cu	NO <sub>3</sub> -N	Pb	Sb	SO <sub>4</sub> <sup>2-</sup>		Zn
	m <sup>3</sup> /t <sup>i</sup>	I: indirect D: direct	g/t <sup>1</sup> (mg/l)	g/t <sup>1</sup> (mg/l)	g/t <sup>1</sup> (mg/l)	g/t <sup>1</sup> (mg/l)	g/t <sup>1</sup> (mg/l)	g/t <sup>1</sup> (mg/l)	g/t <sup>1</sup> (mg/l)	g/t <sup>1</sup> (mg/l)	g/t <sup>1</sup> (mg/l)	g/t <sup>1</sup> (mg/l)	g/t <sup>1</sup> (mg/l)	g/t <sup>1</sup> (mg/l)	g/t <sup>1</sup> (mg/l)	g/t <sup>1</sup> (mg/l)		g/t <sup>1</sup> (mg/l)
A <sup>1a</sup>	27	I								<sup>2</sup> (0.1)				<sup>15</sup> (0.5)		40 (2000)		
B <sup>1b</sup>	100	D	(30)	(100)				50		5 – 10			40000 – 80000 (300 – 680)	20 – 40	400 – 500			
C <sup>1</sup>		I								(0.08)	(0.07)	(<0.01)		(0.05)		(6)		(0.13)
E <sup>1</sup>		D								(1–2.5) <sup>c</sup> 0.03 – 0.05 <sup>e</sup> (<0.1) <sup>d</sup>								
F and G <sup>2</sup>	18.37	I				4586 – 93557 (250 – 5100)	0 – 107 (0 – 5.8)	(<0.01)	366 – 47695 (20 – 2600)	(<0.05)		0 – 1.47 (0 – 0.08)	0 – 160 (0 – 9.8)	(<0.05)		1687 – 9723 (92 – 530)		1.47 – 8.44 (0.08 – 0.46)
H <sup>3</sup>																		

The values indicated in the table are annual average values. When Bi, V, W occur, they are minimised to values below 1 mg/l.

<sup>1</sup> TWG comments; <sup>2</sup> TWG comments, parameters measured four times a year; <sup>3</sup> TWG comments; <sup>i</sup> Of finished pigment products; <sup>a</sup> Discharge data after treatment (specific load, concentration), prior to final biological treatment; <sup>b</sup> For lead chromate, a recycling of sludge is not viable. Reduction of waste water volume by use of dry filters for waste gas treatment; <sup>c</sup> Cr<sub>total</sub> after pretreatment and before WWTP; <sup>d</sup> Cr(VI) after pretreatment and before WWTP

**Table 6.10: Concentration levels of pollutants measured in the waste water after treatment at several plants producing pigments in Europe**



#### 6.1.3.1.3.1 Iron oxide pigments

##### The precipitation and Penniman-Zoph processes

The manufacture of iron oxide pigments has an average water demand of 100 m<sup>3</sup>/t of finished product. However, for the manufacture of transparent and high purity iron oxide pigments, the water demand increases to 400 m<sup>3</sup>/t of finished product. Pollutant loads and concentrations on a basis of 100 m<sup>3</sup> of water per tonne of finished product in the precipitation process are summarised in Table 6.11.

Parameter	Concentration	Load of pollutants per tonne of finished product
Fe <sub>total</sub>	<5 g/m <sup>3</sup>	<0.5 kg
SO <sub>4</sub> <sup>2-</sup>	<16 kg/m <sup>3</sup>	<1600 kg

**Table 6.11: Pollutants loads and concentrations for the production of iron oxide pigments**

##### The Laux process

The Laux process only requires a catalytic acid volume to dissolve the iron. The aromatic nitro compound oxidises Fe<sup>2+</sup> to Fe<sup>3+</sup>. By the formation of insoluble pigments, free acid is generated, which can be re-used for dissolving the iron further. The acid demand is much lower than the stoichiometric volume. Consequently, the sulphate load of <40 kg/t in the water effluent is considerably lower than in the case of the precipitation process. Also, the base demand for the precipitation of iron from the waste water is significantly lower.

Due to an aniline concentration of up to 3 kg/t of finished product, the leachate is fed into a biological waste water treatment plant after precipitation. Moreover, the effluent is loaded with ammonium, which also has to be eliminated in the biological treatment plant. Waste water from the central water treatment plant is discharged after separation of solid materials (aniline <0.2 kg/t of finished product).

#### 6.1.3.1.3.2 Chromium (III) oxide pigments

The specific water demand is about 60 m<sup>3</sup>/t of pigments produced. The maximum sulphate concentration does not exceed 1200 kg/t. The total chromium concentration in the waste water is <0.02 kg/t of pigments produced.

#### 6.1.3.1.3.3 CIC pigments

The manufacture of complex inorganic coloured pigments has a water demand of up to 150 m<sup>3</sup>/t of pigments produced. In waste water treatment, the average value of dried solid waste is 40 kg/t of pigments produced.

The maximum concentrations of Co, Cr, Cu, Ni, Zn at the output of the WWTP reported by Germany, before mixing with other streams, is 0.5 mg/l, except for Co which is <1 mg/l. Precipitation and flocculation (e.g. lime milk, caustic soda) are suitable methods used to comply with these requirements.

**6.1.3.1.3.4 Zinc sulphide, barium sulphate and lithopone pigments**

The average amount of waste water treated is indicated in Table 6.12.

<b>Pigments produced</b>	<b>Waste water treated per tonne of finished product</b>
Lithopone	40 m <sup>3</sup>
Zinc sulphide	95 m <sup>3</sup>
Barium sulphate	Up to 80 m <sup>3</sup>

**Table 6.12: Average amount of waste water treated in the production of zinc sulphide, barium sulphate and lithopone pigments**

The above figures can vary depending on the required qualities of the finished products.

The waste water is characterised by the concentration of pollutants as indicated in Table 6.13.

<b>Pollutants</b>	<b>Concentration (mg/l)</b>
Barium	<2
Cadmium	<0.01
Sulphide	<1
Zinc	<2

**Table 6.13: Pollutants contained in the waste water from the production of zinc sulphide, barium sulphate and lithopone pigments**

**6.1.3.1.4 By-products and wastes****6.1.3.1.4.1 Iron oxide pigments****Precipitation and Penniman-Zoph processes**

Most of the waste results from the sedimentation stage of the waste water treatment plant. The waste volume (mainly hydroxide sludge) is about 20 to 30 kg of dry material per tonne of pigments produced. If the residues cannot directly be recycled back into the process, several possibilities may be considered:

- recycled and used in the cement industry
- converted into iron brown pigments by calcination
- disposed of appropriately (e.g. controlled landfilling).

**6.1.3.1.4.2 Chromium (III) oxide pigments**

The main waste from the production of chromium (III) oxide pigments is chromium hydroxide which can be partly recycled, sold to other industries or disposed of in a controlled landfill. The amount of waste strongly depends on the product quality required by customers. Maximum values reported for disposed materials are 80 kg/t of pigments produced.

Packaging materials (i.e. paper bags) from the raw chromate material are 100 % thermally recycled (i.e. incinerated): Empty paper sacks cannot be cleaned to the extent that they can be recycled without any interference to the paper recycling process. There is still colouring material in the paper bags, which would give colour to the recycled paper. There are no toxicological reasons for not recycling the packaging materials.

#### 6.1.3.1.4.3 CIC pigments

By-products are recycled back into production; waste deriving from, e.g. broken saggars, packaging materials or waste from water treatments, depends on the type of pigment produced and on the production process used. Waste recovering systems are used where applicable.

#### 6.1.3.1.5 Noise

Technical measures such as encapsulation of process equipment are used where necessary.

#### 6.1.3.1.6 Odour

Generally, odour is not a problem in the production of inorganic pigments. In the case of the production of zinc sulphide and barium sulphate, the reaction is strictly controlled as regards pH value, so that no (odorous) hydrogen sulphide is generated.

### 6.1.4 Techniques to consider in the determination of BAT

#### 6.1.4.1 Use of non-carcinogenic raw materials

##### Description

Internal company policy prevents the use of carcinogenic raw materials.

##### Achieved environmental benefits

- avoids effluent discharges loaded with carcinogenic materials
- health and safety of the workers.

##### Cross-media effects

- none.

##### Applicability

- generally applicable.

##### Driving force for implementation

- workers health and safety.

##### Example plants

- COLOROBRIA, Italy.

### 6.1.4.2 Penniman-Zoph process to manufacture yellow iron oxide pigments

[1, Ullmann, 2001]

#### Description

The Penniman-Zoph process is probably the most widely used production method for yellow iron oxide pigments. This method considerably reduces the quantity of neutral salts formed as by-products. The raw materials are iron (II) sulphate, sodium hydroxide solution, and scrap iron. If the sulphate contains appreciable quantities of salt impurities, these must be removed by partial precipitation. The iron must be free of alloying components. The process usually consists of two stages.

In the first stage, nuclei are prepared by precipitating iron (II) sulphate with alkali (e.g. sodium hydroxide solution) at 20 – 50 °C with aeration. Depending on the conditions, yellow, orange, or red nuclei may be obtained. The nuclei suspension is pumped into vessels charged with scrap iron and diluted with water. Here, the process is completed by growing the iron oxide hydroxide or oxide onto the nuclei. The residual iron (II) sulphate in the nuclei suspension is oxidised to iron (III) sulphate by blasting with air at 75 – 90 °C. The iron (III) sulphate is then hydrolysed to form FeOOH or  $\alpha$ -Fe<sub>2</sub>O<sub>3</sub>. The liberated sulphuric acid reacts with the scrap iron to form iron (II) sulphate, which is also oxidised with air. The reaction time can vary from approximately two days to several weeks, depending on the conditions chosen and the desired pigment.

For accelerating the reaction, the temperature is kept stable at about 80 °C by adding steam. The air quantity has to be controlled to minimise the risk of explosions, but also to minimise emissions of heat and waste gas. One solution to achieve this is to operate above the temperature at which the vapour pressure of water is high enough to blanket the reactor's dome.

At the end of the reaction, metallic impurities and coarse particles are removed from the solid with sieves or hydrocyclones; water-soluble salts are removed by washing. Drying is carried out with band or spray dryers and disintegrators or jet mills are used for grinding.

The iron oxide pigments produced by the Penniman-Zoph process are soft, have good wetting properties, and a very low flocculation tendency.

Under suitable conditions, the Penniman-Zoph process can also be used to produce red pigments directly. The residual scrap iron and coarse particles are removed from the pigment, which is then dried and ground using disintegrators or jet mills. These pigments have unsurpassed softness. They usually have a purer colour than the harder red pigments produced by calcination.

#### Achieved environmental benefits

The main advantage of this process over the precipitation process lies in the small quantity of alkali and iron (II) sulphate required. The bases are only used to form the nuclei and the relatively small amount of iron (II) sulphate required initially is continually renewed by dissolving the iron by reaction with the sulphuric acid liberated by hydrolysis. The process is thus considered environmentally friendly.

The advantage of the Penniman-Zoph process in comparison to the precipitation process is that it considerably reduces the quantity of neutral salts (e.g. Na<sub>2</sub>SO<sub>4</sub>, NaCl) formed as by-products because the sulphuric acid generated by iron (II) sulphate hydrolysis-oxidation reacts with the scrap iron to produce iron (II) sulphate.

#### Reference literature

[1, Ullmann, 2001]

### 6.1.4.3 Fluoride and boron abatement by lime washing

#### Description

The production of some pigments (e.g. zircon pigments, zirconium silicate pigments) cause the presence of fluorides (generated in the calcination process) in the exhaust air coming from the kilns. To abate them, micro-batchers are installed on the outlet of the kiln exhaust gas. Hydrated ventilated lime is the reacting agent contained in the micro-batchers and is introduced into the exhaust airflow using a mixing Venturi tube positioned on the outlet of the kiln exhaust gas. The hydrated lime batched in the system not only reacts with the acidic fumes by virtue of the 'mixing' obtained with the Venturi tube, but also subsequently deposits onto the exterior surface of the filter sleeves forming a thin layer that allows the capture of the gaseous pollutants (i.e. fluorides) that have not yet been neutralised and which are forced to pass through the reactant layer formed. The hydrated lime also serves to abate boron.

#### Achieved environmental benefits

- reduction of fluoride and boron emissions to the air.

#### Cross-media effects

- consumption of reacting agent (i.e. lime).

#### Operational data

At the COLOROBRIA plant in Italy, the efficiency of the fluoride abatement system is in the range of 90 to 98 % and fluoride emission levels are in the range of 0.2 to 2 mg/Nm<sup>3</sup>.

#### Applicability

Applicable for the production of pigments that generate fluorides in the exhaust air coming from the kilns.

#### Driving force for implementation

- environmental regulations.

#### Example plants

- COLOROBRIA, Italy.

#### **6.1.4.4 Use of distilled water coming from the evaporation/concentration system for washing pigments**

##### **Description**

Using distilled water coming from the evaporation/concentration part of the waste water system allows a lesser quantity of water to be used for the washing of pigments because of the elevated solubility power of the distilled water.

##### **Achieved environmental benefits**

- less consumption of water to wash the pigments.

##### **Cross-media effects**

- none.

##### **Operational data**

- COLOROBRIA, Italy makes use of about 6.5 litres of water per kg of pigments produced.

##### **Driving force for implementation**

- environmental regulations.

##### **Example plants**

- COLOROBRIA, Italy.

### 6.1.4.5 Chromium removal from waste water

#### Description

Oxidation of chromium (III) to chromium (VI) occurs in the production of pigments from high temperature calcination in alkaline conditions.

Hexavalent and trivalent chromium compounds – chromium (VI) and chromium (III) – differ very greatly in their effects. Chromium (VI) compounds have a strong tendency to change into chromium (III) while driving out oxygen. Therefore, chromium (VI) compounds have a strong oxidising action and a toxic effect on biological materials. For humans and animals, as well as for plants, they are more than 1000 times more toxic than trivalent chromium compounds [10, ANFFECC/CERAMICOLOR/EPSON/VdMi, 1998].

Waste water loaded with chromium (VI) is commonly treated in a two-stage process.

The first stage changes chromium (VI) to chromium (III) by a reduction reaction (see Section 4.4.1.2.4) using sulphite (e.g. iron (II) sulphate, sulphur dioxide, sodium bisulphite, sodium metabisulphite). The efficiency of the reaction is highly dependent on pH.

The second stage is the addition of calcium hydroxide for the precipitation (see Section 4.4.1.2.1) of chromium hydroxide to occur. The efficiency of the reaction is highly dependent on pH, and most conventional processes are operated with a high pH (>8). The precipitate (sludge) is separated, dehydrated and sent to disposal. Presence of iron (II) in the precipitation/flocculation step reduces chromium (VI) to chromium (III).

#### Achieved environmental benefits

- less emissions of chromium (VI) compounds to the environment, which are the most toxic chromium compounds
- minimise emissions of chromium (III) to the environment.

#### Cross-media effects

- consumption of reducing agents (e.g. sulphur dioxide, sodium bisulphite, sodium metabisulphite)
- consumption of precipitating agents (e.g. calcium hydroxide)
- consumption of flocculants
- consumption of chemicals to regulate the pH (e.g. H<sub>2</sub>SO<sub>4</sub>, NaOH)
- consumption of electricity to operate the agitators in the reaction tank(s).

#### Operational data

At two German plants, the following concentrations are achieved at the outlet of the treatment:

- Cr<sub>total</sub>: 1 – 2.5 mg/l
- Cr(VI): <0.1 mg/l.

#### Applicability

- generally applicable.

#### Example plants

- two plants in Germany.

#### **6.1.4.6 Strict control of the pH value of the reaction**

##### **Description**

In the production of zinc sulphide and barium sulphate pigments, the reaction is strictly controlled as regards pH value, so that no odorous and toxic hydrogen sulphide is generated.

##### **Achieved environmental benefits**

- avoids generation of odorous hydrogen sulphide.

##### **Cross-media effects**

- none.

##### **Applicability**

- generally applicable in the production of zinc sulphide and barium sulphate pigments.

#### **6.1.4.7 Recycling of precipitation sludges back into production**

##### **Description**

Precipitation sludges (hydroxides), resulting from the precipitation of the waste water stream from the production of cadmium pigments, lithopones, precipitated barium sulphate, chromium oxide and iron oxide pigments, are recycled back into the production process.

##### **Achieved environmental benefits**

- minimise the amount of waste to be disposed of
- minimise the amount of raw materials used.

##### **Cross-media effects**

- none.

##### **Applicability**

Generally applicable in the production of cadmium pigments, lithopones, precipitated barium sulphate, chromium oxide and iron oxide pigments.



#### 6.1.4.8 Biological treatment of waste water loaded with nitrates

##### Description

The nitrate loaded streams from the production of bismuth vanadate and lead chromate pigments can be denitrified biologically using carbon nutrient sources such as methanol, ethanol or sugar solutions. In the cases where metals (such as Zn) interfere with the biological processes, they are removed prior to the biological treatment to prevent contamination of the activated sludge.

The treatment steps consist of:

- flow balancing
- first reaction stage (denitrification –  $\text{NO}_3$  to  $\text{N}_2$  – in a stirrer tank where the external carbon source is added)
- second reaction stage (degradation of residual organics in a stirrer tank by addition of small amounts of nitrate)
- separation (the activated sludge is returned to the first reaction stage).

##### Achieved environmental benefits

- minimises the amount of nitrate emitted to receiving waters.

##### Cross-media effects

- treatment and disposal of sludges.

##### Operational data

At a pigments production plant in Germany, the waste water streams with high nitrate-loads are treated using the biological treatment described above. The effluent coming out of this biological treatment is sent to the central WWTP (mainly for neutralisation and precipitation of heavy metals). The following emission levels sent to receiving waters are reported at the outlet of the central WWTP:

- $\text{NO}_3\text{-N}$ : 40000 – 80000 g/t of end-products; 300 – 680 mg/l (with an annual waste water volume treated of 100 m<sup>3</sup>/t of end-products) as indicated in Table 6.10 under Example plant B.

##### Applicability

This technique is applicable for precipitation processes using metal nitrates (e.g. lead nitrate, bismuth nitrate) as precursors.

##### Driving force for implementation

- prevention of eutrophication in receiving waters.

##### Example plants

- SIC pigments production plant in Germany (see Example plant B in Table 6.10).

### 6.1.4.9 Pretreatment of waste water loaded with heavy metals

#### Description

The pretreatment of waste water loaded with heavy metals (e.g. Pb, Sb, Cd) in the production of SIC pigments can consist of:

- equilibration tank
- reduction (of chromate), neutralisation
- precipitation, flocculation, sedimentation
- multistage filtration, membranes
- dewatering of sludge by filter press
- concentrates (filtrate from sludge dewatering, backwash, membranes) are fed back to neutralisation.

It should be noted that the effluent from the pretreatment is directed to the neutralisation step of the waste water treatment plant to prevent any re-dissolution.

#### Achieved environmental benefits

- minimises the amount of heavy metals emitted to water.

#### Operational data

Table 6.14 presents the emission levels achieved after pretreatment and final treatment of waste water loaded with heavy metals.

#### Example plants

- SIC pigments production plant in Germany.

### 6.1.4.10 Final treatment of waste water loaded with heavy metals

#### Description

The final treatment of waste water loaded with heavy metals (e.g. Pb, Sb, Cd) in the production of SIC pigments can consist of:

- equilibration tank
- neutralisation
- precipitation, flocculation, sedimentation
- filtration
- dewatering of sludge by filter press
- filtrate from sludge dewatering and concentrates from backwash are fed back to neutralisation.

#### Achieved environmental benefits

- minimises the amount of heavy metals emitted to water.

#### Operational data

Table 6.14 presents the emission levels achieved after pretreatment and final treatment of waste water loaded with heavy metals.

Parameter	Emission factor <sup>1</sup>	Concentration <sup>1</sup>
Pb	20 – 30 g/t	
Cr	5 – 7.5 g/t	
Sb	0.4 – 0.5 kg/t	
COD		100 mg/l
BOD <sub>5</sub>		30 mg/l
Bi, V, W		Below detection limit
Cd	50 g/t	
<sup>1</sup> Yearly average values		

**Table 6.14: Emission levels achieved after pretreatment and final treatment of waste water loaded with heavy metals**

#### Example plants

- SIC pigments production plant in Germany.

## 6.1.5 Best Available Techniques

Noting the introduction of BAT given in Chapter 5 and remembering that generic BAT for the SIC sector are also defined in Chapter 5, this section presents specific BAT conclusions generally applicable to the production of speciality inorganic pigments. Therefore, BAT for the production of speciality inorganic pigments is the combination of the generic elements presented in Chapter 5 and the specific elements indicated in this section.

### Production route for the manufacture of iron oxide pigments

For new installations, BAT is to:

- 6.1.1 manufacture iron oxide pigments by the Penniman-Zoph process in order to reduce the quantity of neutral salts formed as by-products (see Section 6.1.4.2).

When the Penniman-Zoph process is used, BAT is to:

- 6.1.2 control the air quantity in the reactor to minimise the risk of explosions, the emission of heat and the amount of off-gases generated (see Sections 6.1.4.2 and 6.1.2.4.1).

### Minimisation of auxiliary materials used

In the production of chromium oxide pigments by the reduction of sodium dichromate with sulphur, BAT is to:

- 6.1.3 use sulphuric acid produced by abating SO<sub>2</sub> in the off-gases from the kiln for acidifying the waste water before the reduction of chromate (see Section 6.1.2.5.1).

### Reduction of diffuse dust emissions

BAT is to:

- 6.1.4 capture dust in the work areas (e.g. weighing, loading of refractory boxes, packaging steps) and duct it to be abated (see Section 4.7.6). The dust captured is recycled back into production when there is no adverse effect on pigment quality.

BAT is to:

- 6.1.5 regularly vacuum the work areas (see Section 4.7.6).

BAT is to:

- 6.1.6 carry out regular housekeeping (see Section 4.7.6).

### Minimisation of acid gases and fluoride emissions to the air

BAT is to:

- 6.1.7 minimise the emission of acid gases (e.g. SO<sub>2</sub>, SO<sub>3</sub>, HCl, HF) and fluorides by using, e.g. sorbent injection techniques (see Section 6.1.4.3, Section 4.4.2.3.1 and Section 6.1.3.1.2.2).

Minimisation of total dust emissions to the air

BAT is to:

- 6.1.8 minimise the emission of total dust from the activities carried out at the installation and achieve emission levels of 1 – 10 mg/Nm<sup>3</sup> (see Table 6.8) by using one or more of the following abatement techniques (see Section 6.1.2.3.1):
- cyclone (see Section 4.4.2.1.2)
  - fabric filter (see Section 4.4.2.1.5)
  - wet scrubber (see Section 4.4.2.1.3). The waste water generated by the scrubbing operation is re-used as scrubbing media or recycled
  - ESP (see Section 4.4.2.1.4).

The lower end of the range may be achieved by using fabric filters in combination with other abatement techniques. Using fabric filters is not always possible, e.g. when other pollutants have to be abated (e.g. SO<sub>x</sub>) or when the off-gases present humid conditions (e.g. presence of liquid acid).

Choice of waste gas treatment system

In order to reduce the consumption of water, BAT is to:

- 6.1.9 use a dry treatment system to treat off-gases from calcination kilns except when other pollutants, besides total dust, also have to be abated (see Section 6.1.3.1.2).

In order to ensure high abatement efficiency of pollutants, BAT is to:

- 6.1.10 use ESPs to clean off-gases from dryers under humid conditions and bag filters under low humidity conditions (see Section 6.1.2.4.1.1).

Waste water treatment

BAT is to:

- 6.1.11 (pre)treat waste water contaminated with Cr(VI) and achieve a Cr(VI) concentration of <0.1 mg/l (see Table 6.10) by applying both of the following measures before sending the effluent for further treatment (see Sections 4.4.1 and 6.1.4.5):
- flow buffering
  - reduction of Cr(VI) to Cr(III) e.g. by sulphite, iron(II) sulphate

BAT is to:

- 6.1.12 treat waste water loaded with heavy metals and achieve the emission levels indicated in Table 6.15 before discharging to the receiving water by a combination of precipitation (see Section 4.4.1.2.1), flocculation, sedimentation (see Section 4.4.1.1.1) and filtration (see Section 4.4.1.1.3). The filtration residues recovered from waste water treatment may be recycled back into production (see Sections 4.4.1, 6.1.2.3.2 and 6.1.3.1.3).

<b>Pollutant</b>	<b>Emission factor<sup>1</sup></b> (g/t of end-product)	<b>Concentration<sup>1</sup></b> (mg/l)
Cd	50	
Cr <sub>total</sub>	5 – 10	≤ 0.1
Pb	20 – 40	<0.5

<sup>1</sup> Data are given as annual averages

**Table 6.15: Emission levels associated with BAT 6.1.12**

In the manufacture of iron oxide pigments by the Laux process, BAT is to:

- 6.1.13 use biological treatment for the abatement of organic traces in the waste water (see Section 6.1.2.3.2).

In the manufacture of bismuth vanadate and lead chromate pigments, BAT is to:

6.1.14 reduce NO<sub>3</sub>-N emissions to water by approximately 50 % by using denitrification treatment (see Section 6.1.4.8).

### Recycling of precipitation residues containing pigments

In the production of cadmium pigments, lithopones, precipitated barium sulphate, chromium oxide and iron oxide pigments, BAT is to:

6.1.15 recycle back into production filtration residues from the precipitation steps of the waste water stream (see Section 6.1.4.7).

### **6.1.6 Emerging techniques**

Emerging techniques are not seen in the mature and old (historic) European inorganic pigment industry.

## 6.2 Phosphorus compounds

[1, Ullmann, 2001, 2, Dr. Köppke, 2003, RHODIA, 2000 #4, 3, UNEP, et al., 1989]

Within the scope of this document, phosphorus compounds signify the speciality inorganic chemical (SIC) substances containing phosphorus, where the meaning of 'speciality' is defined in the Scope section of this document. Non-speciality inorganic chemicals containing phosphorus are addressed in the Reference Document on Best Available Techniques for the production of Large Volume Inorganic Chemicals (Solids and others) [24, European IPPC Bureau, 2004] for detergent, food and feed phosphates, and in the Reference Document on Best Available Techniques in the Large Volume Inorganic Chemicals, Ammonia, Acids and Fertilisers Industries [45, European IPPC Bureau, 2004] for phosphoric acid and phosphorus fertilisers.

The SIC phosphorus compounds addressed in this document are those that are of industrial and economic importance in Europe, namely **phosphorus trichloride (PCl<sub>3</sub>)**, **phosphoryl chloride (POCl<sub>3</sub>)** and **phosphorus pentachloride (PCl<sub>5</sub>)**. The exchange of information mainly benefits the production of phosphorus trichloride and phosphoryl chloride as there is only one producer of phosphorus pentachloride in Europe. Production of PCl<sub>3</sub>, POCl<sub>3</sub> and PCl<sub>5</sub> are closely related as PCl<sub>3</sub> is the starting material for the production of the other two compounds.

Other phosphorus compounds that could be considered SIC substances are produced in Europe, such as phosphorus pentasulphide (P<sub>2</sub>S<sub>5</sub>) and phosphorus thiochloride (PSCl<sub>3</sub>), but are not specifically addressed in this section due to their low production volumes (<1000 tonnes/year for each substance).

### 6.2.1 General information

**Phosphorus trichloride (PCl<sub>3</sub>)** is a clear, colourless to slightly yellow, oily liquid that fumes in moist air. It has a pungent, irritating odour. PCl<sub>3</sub> reacts exothermically with water to form phosphorous/phosphonic and hydrochloric acid and phosphine gases. It is neither flammable nor explosive.

**Phosphoryl chloride (POCl<sub>3</sub>)**, also called phosphorus oxychloride, is a colourless liquid which fumes in air and has a pungent odour. The violent exothermic reaction of POCl<sub>3</sub> with water forms phosphoric acid and HCl. It is neither flammable nor explosive.

**Phosphorus pentachloride (PCl<sub>5</sub>)** is a white to yellow, crystalline mass when pure. It fumes in air and has a strong, pungent odour. The substance decomposes on heating producing toxic and corrosive fumes including hydrogen chloride and phosphorus oxides. It reacts violently with water or moisture to form phosphoric acid and hydrogen chloride.

#### 6.2.1.1 Uses

**Phosphorus trichloride (PCl<sub>3</sub>)** is the most important phosphorus-halogen compound as it serves as a starting material for phosphorus acid, aliphatic acid chloride, di- and tri-alkylphosphonate (used in pre-products for agricultural pesticides), tri-alkyl phosphonate (used as a stabiliser for plastic materials), phosphone acid (used as water treatment chemicals), phosphorus pentachloride, phosphorus sulphochloride, and phosphoryl chloride.

**Phosphoryl chloride (POCl<sub>3</sub>)** is mainly used for the manufacture of the aliphatic and aromatic esters of phosphoric acid that is used in plasticisers, hydraulic fluids, pesticides, flame-retardants, and in the manufacture of several pharmaceuticals. Phosphoryl chloride is also used as a solvent in cryoscopy [2, Dr. Köppke, 2003, 3, UNEP, et al., 1989].

**Phosphorus pentachloride** ( $\text{PCl}_5$ ) is mainly used as a chlorinating agent in organic chemistry. It is also used in the pharmaceutical industry for the manufacture of penicillin and cephalosporin antibiotics.

As all three compounds can be used to produce nerve gases, their use is strictly controlled according to the Chemical Weapons Convention.

### 6.2.1.2 Toxicity

On contact with moisture, **phosphorus trichloride** is hydrolysed in an exothermic reaction forming phosphorous/phosphonic acid and hydrogen chloride. Therefore, it is strongly irritating to the skin, eyes, and respiratory tract. Severe corrosion of the skin and mucous membranes may occur upon contact with liquid  $\text{PCl}_3$  [1, Ullmann, 2001].

**Phosphoryl chloride** hydrolyses slowly but exothermically to give phosphoric acid and hydrogen chloride. Therefore, phosphoryl chloride primarily has an irritant action, whereas deeper penetration into the respiratory tract is possible due to delayed hydrolysis. Often, no complaints are felt at the beginning; only after a latent period of several hours does damage to the deeper respiratory tract occur. Irreversible damage may occur following high exposure. For this reason,  $\text{POCl}_3$  is regarded toxicologically as the most dangerous of the phosphorus chlorides [1, Ullmann, 2001].

**Phosphorus pentachloride** vapours are similarly strongly irritating to the mucous membranes and respiratory tract [1, Ullmann, 2001].

These properties necessitate special arrangements for the production, storage and handling of  $\text{PCl}_3$ ,  $\text{POCl}_3$  and  $\text{PCl}_5$ .

### 6.2.1.3 Explosions and fire hazards

Phosphorus trichloride, phosphoryl chloride, and phosphorus pentachloride do not burn or explode, but when they come into contact with water, they may splash over a wide area. The violent reaction of these substances with water may ignite other combustible materials. When heated to decomposition, they emit toxic fumes. During fires, containers should be kept cool with water spray but only if there is no risk of contact between the product and the water.

In emergency situations, a positive pressure-demand/self-contained breathing apparatus, with complete chemically resistant clothing, should be used, and fire-fighters should wear compressed-air breathing apparatus. For mixed fires, if there is no risk of contact between the phosphorus trichloride, phosphoryl chloride or phosphorus pentachloride and the fire-fighting medium, the medium can be chosen according to the other chemicals involved. Otherwise, dry foam or inert gases (e.g. argon) should be used as the fire-fighting medium.

### 6.2.1.4 Phosphorus compounds production in Europe and worldwide

In 2005 in Europe, phosphorus trichloride, phosphoryl chloride and phosphorus pentachloride were produced by six companies at six sites (three in Germany, one in France, one in Poland, and one in the United Kingdom), each producing between 10000 and 95000 tonnes of these products per year.

The estimated 2002 production capacity of **phosphorus trichloride** in western Europe and the US amounted to 600000 tonnes (20000 tonnes in Japan). The world production capacity in 2002 was estimated to be greater than 900000 tonnes. The estimated 2002 production capacity of **phosphorus oxychloride** in western Europe was 110000 tonnes (40000 tonnes in the US and 30000 tonnes in Japan).



### 6.2.1.5 Features of the European phosphorus compounds industry

In Europe, large enterprises with over 250 employees manufacture phosphorus compounds. Production is carried out in multipurpose plants using a continuous mode of operation. The workforce employed to run the phosphorus compounds production facilities within these large companies, is generally below 60. Production is generally carried out in installations that are part of a larger chemical complex where the chlorine raw material is produced.

### 6.2.1.6 Economics

The purchase of the elemental phosphorus raw material represents a vast amount of the total  $\text{PCl}_3$  production cost and, therefore, of the  $\text{POCl}_3$  and  $\text{PCl}_5$  derivatives. There is only one producer of elemental phosphorus in Europe.

Competition from within Europe is strong due to the presence of a total of six producers of phosphorus compounds (four major producers and two minor ones). In addition, European producers are exposed to competition from Indian and Chinese producers, but only to a limited extent because of the high costs of shipment. The main markets for phosphorus compounds are in agriculture and in the production of flame-retardants. The growth rate of these two markets is moderate (2 to 4 % per year). Due to the high transportation costs, European producers mainly serve the European markets and only a small proportion of phosphorus chlorides is exported outside Europe.

## 6.2.2 Applied processes and techniques

### 6.2.2.1 Process chemistry

**Phosphorus trichloride** is formed by the reaction of elemental phosphorus with chlorine. The reaction is highly exothermic.



**Phosphoryl chloride** is obtained by oxidising phosphorus trichloride with air or oxygen.



**Phosphorus pentachloride** can be prepared by the reaction of excess chlorine with phosphorus trichloride. The reaction is slightly exothermic.

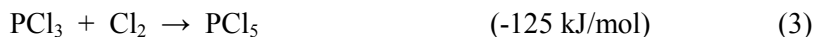

### 6.2.2.2 Production processes

Production of  $\text{PCl}_3$ ,  $\text{POCl}_3$  and  $\text{PCl}_5$  are closely related as  $\text{PCl}_3$  is the starting material for the production of the other two compounds. For this reason, production of all three compounds is often carried out in the same installation.

#### 6.2.2.2.1 Production of $\text{PCl}_3$

In Europe, **phosphorus trichloride** is manufactured by two different processes:

- the gas-liquid reaction process
- the gas phase reaction process.

6.2.2.2.1.1 Production of  $\text{PCl}_3$  by the gas-liquid reaction process

In a typical continuous process, molten elemental phosphorus and gaseous chlorine are continuously fed into a reactor filled with boiling (and previously produced) phosphorus trichloride as shown in Figure 6.10. The reaction is highly exothermic, the heat being discharged by evaporation of  $\text{PCl}_3$ . The yield of the reaction is over 99.9 % related to the use of chlorine.  $\text{N}_2$  is used to suppress moisture and oxygen in the reactor in order to avoid the formation of unwanted  $\text{POCl}_3$ .

The formation of phosphorus pentachloride is prevented by the presence of a small excess of elemental phosphorus. The heat of the reaction, about ten times the heat of evaporation, keeps the system at its boiling point, and the phosphorus trichloride distils off. The vapours are fractionated as reflux takes place, and  $\text{PCl}_3$  condenses at  $75.5\text{ }^\circ\text{C}$  in air-cooled or water-cooled condensers. The rate of removal of  $\text{PCl}_3$  (i.e. the production rate) is equivalent to the feed rate of phosphorus and chlorine. The process is controlled by the boiling temperature, which is determined by the phosphorus trichloride content. The rate of chlorine flow is fixed, and the phosphorus feed rate is adjusted manually. The phosphorus trichloride produced contains no free phosphorus and needs no further treatment [1, Ullmann, 2001, 2, Dr. Köpke, 2003].

The organic impurities from the phosphorus used remain in the reactor, and are removed periodically, i.e. the phosphorus trichloride is completely driven off by distillation, and the tarry mass remaining is removed as waste and sent to a suitable waste treatment facility. The volume of organic residues significantly depends on the purity of the phosphorus raw material.

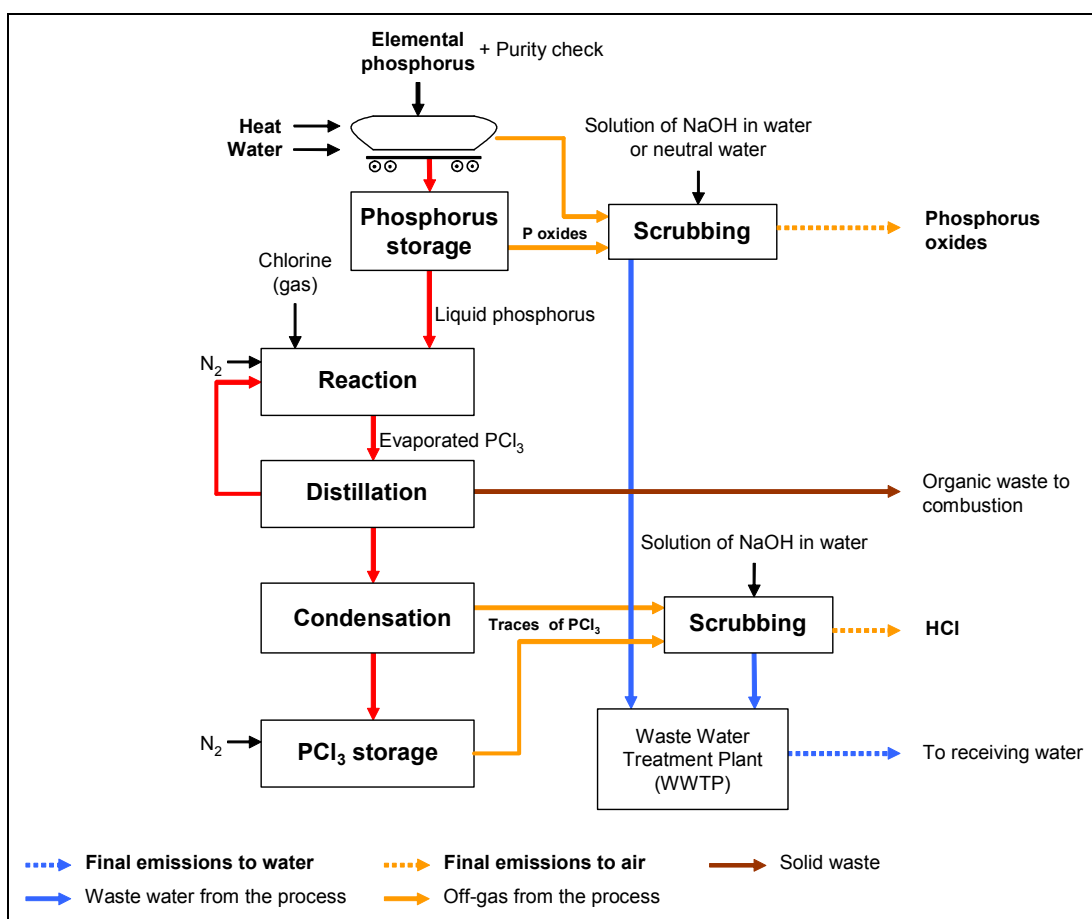

Figure 6.10: Production of phosphorus trichloride by the gas-liquid reaction process

6.2.2.2.1.2 Production of  $\text{PCl}_3$  by the gas phase reaction process

In another process (Figure 6.11), phosphorus and gaseous chlorine are reacted in a combustion chamber to form phosphorus trichloride at about 1800 °C. The yield of the reaction is over 99.5 %, relating to the use of phosphorus (which is equivalent to over 99.9 % yield relating to the use of chlorine), and depending on the purity of the white/yellow elemental phosphorus raw material (impurities such as arsenic and antimony as well as organic constituents can be found in the phosphorus raw material).  $\text{N}_2$  is used to suppress moisture and oxygen in the combustion chamber in order to avoid formation of unwanted  $\text{POCl}_3$ .

Crude  $\text{PCl}_3$  undertakes two steps of distillation/condensation. The first step is used to separate pure  $\text{PCl}_3$  from by-products such as organic chlorides. By-products are sent to the second distillation/condensation step. Distillate  $\text{PCl}_3$  is recycled back into the process and liquid residues are collected and sent for incineration.

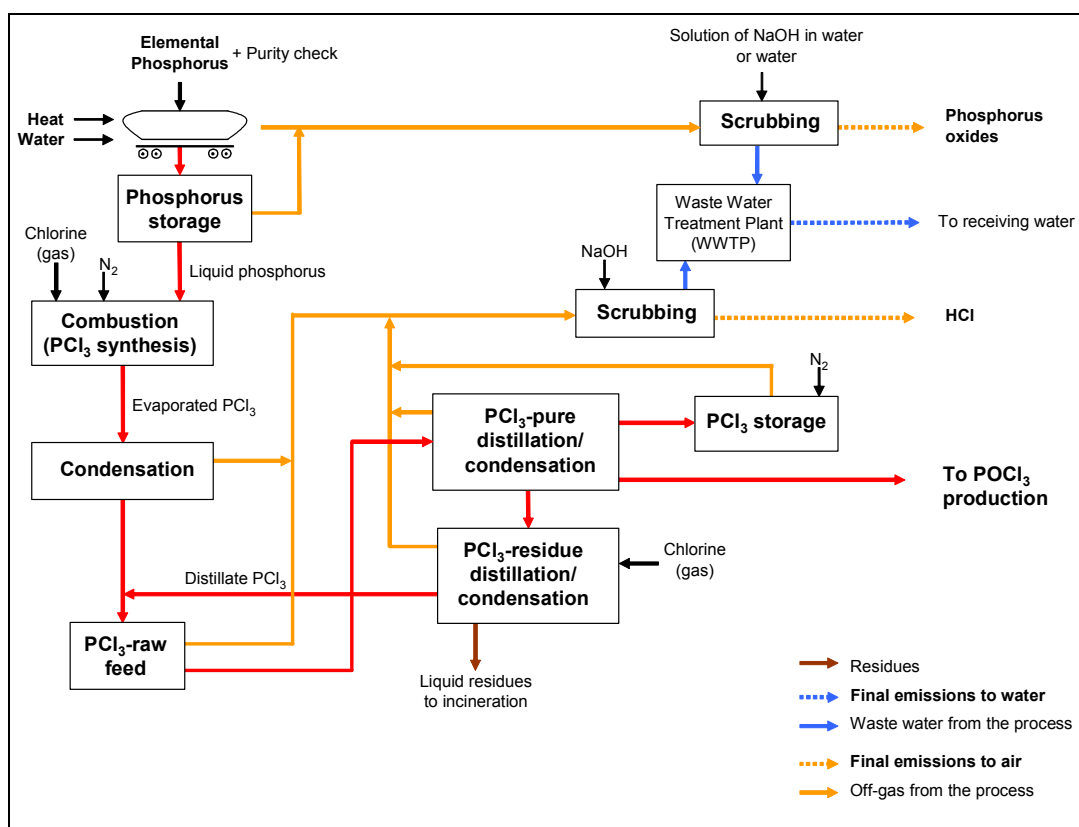

Figure 6.11: Production of phosphorus trichloride by gas phase reaction

6.2.2.2.2 Production of  $\text{POCl}_3$ 

**Phosphoryl chloride** can be manufactured either batch wise or in a continuous process [1, Ullmann, 2001].

Industrially, phosphoryl chloride is manufactured in a continuous mode of operation in two reactors, which are connected by a line as shown in Figure 6.12.  $\text{O}_2$  required for converting  $\text{PCl}_3$  to  $\text{POCl}_3$  is first led countercurrently to the follow-up reactor. The unreacted part of the  $\text{O}_2$  is then fed into the reactor, so that all of the  $\text{O}_2$  brought into the process reacts. The yield of the reaction is over 99.9 % related to the use of  $\text{PCl}_3$ . The presence of impurities in the  $\text{PCl}_3$  raw material such as copper and cobalt, or of sulphur compounds, decreases the reaction rate. The reaction product can be distilled in fractions for further purification [1, Ullmann, 2001, 2, Dr. Köppke, 2003].

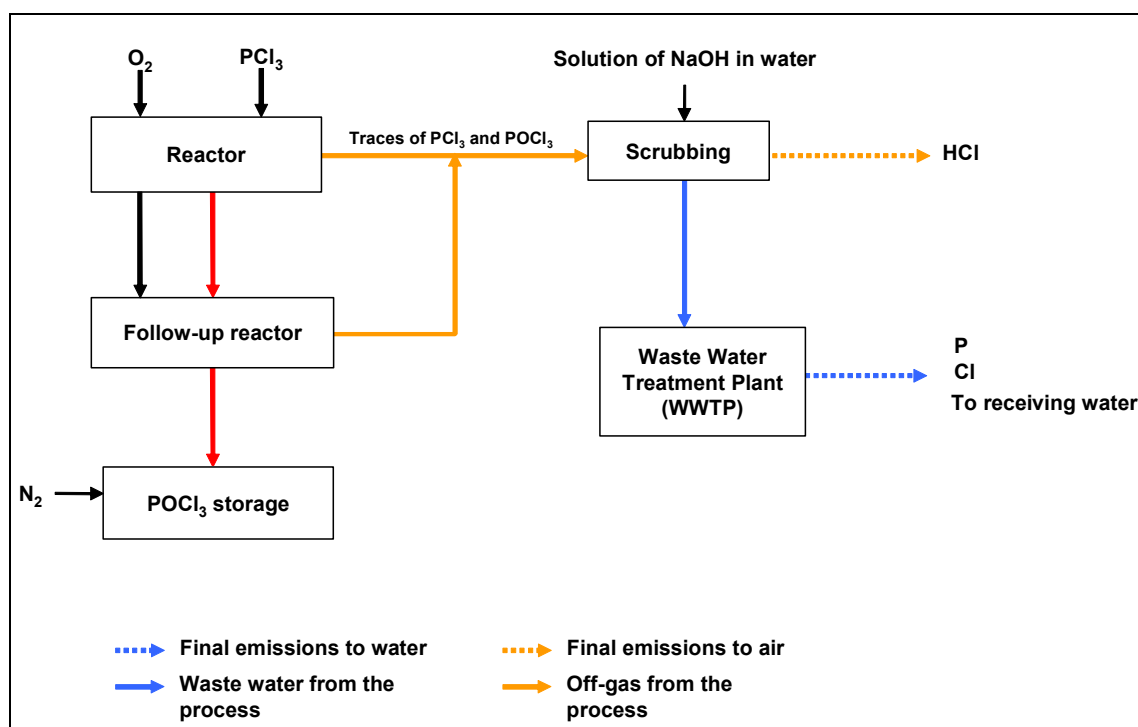

Figure 6.12: Production of phosphoryl chloride

Waste gases leaving the reactors contain traces of  $\text{PCl}_3$  and  $\text{POCl}_3$ . Before being discharged to the air, they are led over an alkaline or neutral scrubber. The wash-water discharged from the scrubber is fed to a waste water treatment plant with biological treatment [2, Dr. Köppke, 2003].

#### 6.2.2.2.3 Production of $\text{PCl}_5$

**Phosphorus pentachloride** can be manufactured industrially by reacting phosphorus trichloride with chlorine as shown in Figure 6.13. The heat of the reaction is removed by the latent heat of evaporation of  $\text{PCl}_3$  and by indirect cooling of the reactor. The conversion takes place up to a point where all of the  $\text{PCl}_3$  has reacted. Phosphorus pentachloride is discharged from the reactor as a fine yellow crystalline powder. Vaporised  $\text{PCl}_3$  is recovered and can be recycled back into the production process.

Waste gases leaving the reactors contain traces of  $\text{PCl}_3$ . Before being discharged to the air, it is led over an alkaline scrubber. The wash-water discharged from this process is fed to a waste water treatment plant with biological treatment.

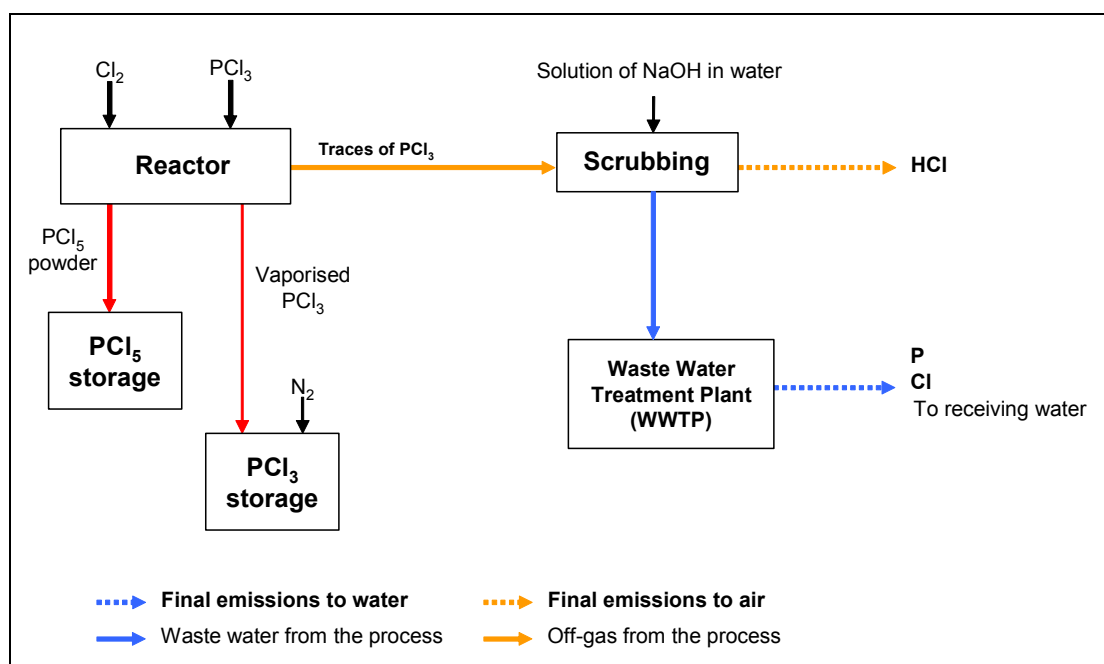

Figure 6.13: Production of phosphorus pentachloride

### 6.2.2.3 Raw material storage and handling

For the production of  $\text{PCl}_3$ , elemental white/yellow phosphorus arrives in solid form to the installation, in 50 tonnes railcars or 25 tonnes ISO tank containers.

Elemental phosphorus is heated up with steam while in the railcar (the heating process lasts approximately six hours) and is transferred in liquid form to storage tanks. A water blanket is permanently maintained on top of the liquid elemental phosphorus in the storage tanks in order to avoid contact with air (elemental white/yellow phosphorus ignites spontaneously when in contact with air). Storage tanks are maintained at a heated temperature of approximately 60 °C to ensure that the elemental phosphorus remains in a liquid form.

Chlorine is generally produced in a nearby plant located on the premises of the chemical complex and sent by pipes in gaseous form to the phosphorus production plant. If not produced nearby, chlorine can be transported by road or rail to the phosphorus production plant.

$\text{PCl}_3$  and  $\text{O}_2$  are the raw materials used for the production of  $\text{POCl}_3$ .  $\text{PCl}_3$  comes from the phosphorus installation tank farm and  $\text{O}_2$  is provided as a utility from the chemical complex.

$\text{PCl}_3$  and chlorine are the raw materials used for the production of  $\text{PCl}_5$ .  $\text{PCl}_3$  comes from the tank farm and chlorine is provided by a nearby plant or transported by road or rail to the phosphorus production plant.

NaOH is the only auxiliary chemical used in the production of phosphorus chlorides. It is used in the scrubbers needed to abate the pollutants contained in waste gases.

### 6.2.2.4 Finished products storage and handling

Storage of liquid  $\text{PCl}_3$  and  $\text{POCl}_3$  necessitates maintaining an  $\text{N}_2$  atmosphere on top of the tanks. Liquid  $\text{PCl}_3$  and  $\text{POCl}_3$  are both pumped from storage tanks into steel drums, road or rail containers for transportation to customers.

### 6.2.2.5 Materials used for production equipment

Production equipment is made of stainless steel, nickel or nickel alloy (reactors), enamelled or plastic coated iron (distillation part).

### 6.2.3 Consumption and emission levels

Consumptions and emissions for the production of phosphorus compounds are depicted in Figure 6.10, Figure 6.11, Figure 6.12, and Figure 6.13.

#### 6.2.3.1 Energy consumption

**Phosphorus trichloride:** the reaction is highly exothermic. The heat discharge is carried out by air chilling. Energy is only required for the ventilation of the cooling system. The energy demand significantly depends on the production volume, the type of cooling system and the outer temperature.

#### 6.2.3.2 Water consumption

Water is used in the production of phosphorus compounds for:

- washing waste gases in scrubbers
- cleaning equipment
- cooling equipment.

#### 6.2.3.3 Air emissions

HCl is the major pollutant emitted to the air in the production of phosphorus compounds.

Most of the phosphorus chloride plants produce more than one phosphorus compound but have a combined off-gas treatment. It is, therefore, difficult to determine the off-gas stream and monitor the air emission corresponding to the production of each phosphorus compound.

In the production of **phosphorus trichloride** (Figure 6.10 and Figure 6.11), the waste gas originates from the reactor and contains traces of  $\text{PCl}_3$  which is abated in a scrubber. The waste gas volume is very small (40 – 100  $\text{m}^3/\text{day}$ ; estimated as part of the total off-gas stream of the plant). Final emissions to the air contain traces of HCl. Vent gases from the railcar and storage of elemental phosphorus need to be led to a scrubber to remove traces of phosphorus oxides.

In the production of **phosphoryl chloride** (Figure 6.12), the waste gas originates from the reactors and contains traces of  $\text{PCl}_3$  and  $\text{POCl}_3$ . The waste gas is led to an alkaline scrubber to abate the pollutants. Final emissions to the air contain traces of HCl.

In the production of **phosphorus pentachloride** (Figure 6.13), the waste gas originates from the reactor and contains traces of  $\text{PCl}_3$ . It is abated in an alkaline scrubber. Final emissions to the air contain traces of HCl.

HCl emissions at the three German plants are reported to be in the range of 3 – 15  $\text{mg}/\text{Nm}^3$ . This corresponds to the range of emissions observed during normal, steady-state operating conditions. It has to be kept in mind that the range indicated takes into account that the emission profile is not constant and does not stem from only one production line, but consists of the added emissions of two to four different parallel production lines. Some of these lines produce substances other than  $\text{PCl}_3$ ,  $\text{POCl}_3$  and  $\text{PCl}_5$ .

### 6.2.3.4 Water emissions

In the production of **phosphorus trichloride** (Figure 6.10 and Figure 6.11), waste water from waste gas scrubbing is led to a waste water treatment plant with biological treatment. The waste water is characterised by a (organic) chloride and phosphorus compound pollutant load. The type of pollutant results from the different scrubbing conditions (neutral or alkaline scrubbing). Neutral scrubbing conditions cause phosphorous/phosphonic acid ( $\text{H}_3\text{PO}_3$ ) and HCl loads in the waste water. The following reaction occurs in the neutral scrubber:

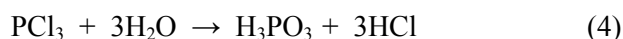

Sodium phosphate ( $\text{Na}_3\text{HPO}_3$ )/sodium hypophosphite monohydrate ( $\text{Na}_2\text{HPO}_3 \cdot \text{H}_2\text{O}$ ) and NaCl are produced with alkaline conditions. The concentration of the above-mentioned pollutants depends on the scrubbing water volumes and on the type of scrubbing process and can widely differ. The following reactions occur in an alkaline scrubber:

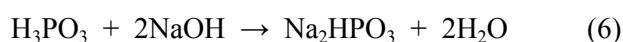
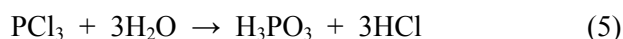

In the production of **phosphoryl chloride** (Figure 6.12), waste water caused by alkaline off-gas scrubbing is led to a waste water treatment plant with biological treatment.

In the production of **phosphorus pentachloride** (Figure 6.13), wash-water from the off-gas scrubbing is led to a waste water treatment plant with biological treatment.

Total waste water volume from the production of phosphorus compounds greatly varies from one producer to the other and are reported to be  $<10 \text{ m}^3/\text{t}$  of elemental phosphorus used.

The pollutants load in total waste water are reported to be the following:

- 0.5 – 2 kg P/t of elemental phosphorus
- 5 – 10 kg Cl/t of elemental phosphorus.

As described in the CWW BREF [21, European IPPC Bureau, 2003], Cl normally passes unchanged through a waste water treatment plant; and the excess of phosphates, as long as they are not used and consumed as bacteria feed in the WWTP with biological treatment, are generally removed by precipitation (using iron or aluminum salts) depending on the amount present so that phosphorous removal is very efficient.

### 6.2.3.5 Wastes

White/yellow phosphorus raw material used in the production of **phosphorus trichloride** contains organic and inorganic impurities, which are released during the production process and have to be eliminated as waste. Such waste arises as distillation residues from  $\text{PCl}_3$  production. The most important impurity in the white/yellow phosphorus raw material being arsenic, waste from the production of **phosphorus trichloride** is hazardous. The share of waste typically represents about 0.5 % of the used phosphorus raw material (by weight), essentially depending, however, on the quality of the phosphorus sources. Wastes are generally led to incineration.

Wastes (i.e. distillation residues from  $\text{PCl}_3$  production) sent to incineration are reported to be in the range 4 – 8 kg/t of elemental phosphorus.

No residues are produced in the manufacture of **phosphoryl chloride** due to the high purity of the  $\text{PCl}_3$  raw material.

The manufacture of **phosphorus pentachloride** does not generate any kind of waste due to the high purity of the  $\text{PCl}_3$  raw material.

## **6.2.4 Techniques to consider in the determination of BAT**

### **6.2.4.1 Use hot condensate water to melt elemental phosphorus and to keep it in liquid form**

#### **Description**

White/yellow elemental phosphorus arriving to the site in solid form needs to be molten (the melting point of phosphorus is 44.1 °C) in order to react with chlorine to form  $\text{PCl}_3$ . The energy required to melt phosphorus can be provided by hot condensate water coming from other parts of the process, thus reducing the use of fresh water and the consumption of energy.

#### **Achieved environmental benefits**

- reduction of energy consumption
- reduction of emissions to air (heating of the water would generate – indirect – emissions)
- reduction of water consumption.

#### **Cross-media effects**

- none.

#### **Applicability**

- generally applicable when condensate water is available at, or close to the installation.

#### **Economics**

- very low costs.

#### **Example plants**

- LANXESS Phosphorchloride unit in Leverkusen, Germany.



#### **6.2.4.2 Use of an inert gas (typically N<sub>2</sub>) to blanket elemental phosphorus raw material**

##### **Description**

Elemental phosphorus is flammable in contact with air and, therefore, needs to be blanketed with an inert medium up to the reaction step. An inert gas (typically N<sub>2</sub>) can be used for this purpose.

##### **Achieved environmental benefits**

- reduced risk of fire.

##### **Cross-media effects**

- generation of off-gases released to the environment.

##### **Driving force for implementation**

For safety reasons, elemental phosphorus which is flammable when in contact with air, needs to be blanketed with an inert medium.

#### **6.2.4.3 Use of water to blanket the elemental phosphorus raw material and recycling of the water for off-gas scrubbing**

##### **Description**

Phosphorus is flammable when in contact with air and, therefore, needs to be blanketed with an inert medium up to the reaction step. Water can be used for this purpose. Before being released to the waste water treatment plant, the water can additionally be used to wash the off-gases (containing phosphorus oxides) generated during the unloading and storage of elemental phosphorus.

##### **Achieved environmental benefits**

- reduction of the risks of fire
- reduction of the volume of water used in waste gas scrubbing.

##### **Cross-media effects**

- generation of waste water.

##### **Applicability**

- generally applicable.

##### **Driving force for implementation**

- safety reasons.

##### **Example plants**

- LANXESS Phosphorchloride unit in Leverkusen, Germany.

#### **6.2.4.4 Use of elemental phosphorus raw material containing low organic and inorganic impurities**

##### **Description**

White/yellow elemental phosphorus raw material used for the production of phosphorus trichloride contains impurities which are released during the production process and have to be eliminated as waste.

Using white/yellow elemental phosphorus raw materials with a low content of impurities allows the amount of waste generated in the production process to be reduced.

##### **Achieved environmental benefits**

- reduction in the amount of waste generated in the process.

##### **Cross-media effects**

- none.

##### **Applicability**

- generally applicable.

##### **Economics**

- reduction of waste treatment costs.

##### **Example plants**

- Thermphos, Germany.

#### 6.2.4.5 Use of neutral scrubbing for abating $\text{PCl}_3$ and phosphorus oxides in waste gases

##### Description

Waste gases are cleaned by means of neutral scrubbers.

##### Achieved environmental benefits

- reduce emissions of  $\text{PCl}_3$  (HCl) and  $\text{P}_2\text{O}_5$  ( $\text{H}_3\text{PO}_4$ ) to the air.

##### Cross-media effects

- generation of  $\text{HCl}(\text{NaCl})/\text{H}_3\text{PO}_4(\text{Na}_3\text{PO}_4)$  in the waste water.

##### Applicability

- generally applicable.

##### Example plants

- Thermphos, Germany
- LANXESS, Germany.

#### 6.2.4.6 Use of alkaline scrubbing for abating $\text{PCl}_3$ in waste gases

##### Description

Waste gases are cleaned by means of alkaline scrubbers.

##### Achieved environmental benefits

- reduce emissions of  $\text{PCl}_3$  (HCl) and  $\text{P}_2\text{O}_5$  ( $\text{H}_3\text{PO}_4$ ) to the air.

##### Cross-media effects

- generation of  $\text{HCl}(\text{NaCl})/\text{H}_3\text{PO}_4(\text{Na}_3\text{PO}_4)$  in the waste water
- consumption of sodium hydroxide (NaOH).

##### Applicability

- generally applicable.

##### Example plants

- Thermphos, Germany.

#### 6.2.4.7 Use of strictly enclosed systems

##### Description

As phosphorus trichloride, phosphoryl chloride and phosphorus pentachloride are highly reactive and hazardous corrosive materials, they are handled in strictly enclosed systems. Warnings and information labels are placed on all pipes and equipment.

##### Achieved environmental benefits

- protection of the workers
- reduction of spills.

##### Cross-media effects

- none.

##### Applicability

- generally applicable.

##### Example plants

- Thermphos, Germany
- LANXESS, Germany.

##### Reference literature

[3, UNEP, et al., 1989]

#### 6.2.4.8 Incineration of the distillation residues from the $\text{PCl}_3$ production

##### Achieved environmental benefits

- energy recovery.

##### Cross-media effects

- none.

##### Applicability

- general applicability.

##### Example plants

- Thermphos, Germany
- LANXESS, Germany.

### 6.2.4.9 Storage measures for phosphorus compounds

#### Description

[3, UNEP, et al., 1989]

Phosphorus trichloride, phosphoryl chloride, and phosphorus pentachloride are stored in properly sealed and labelled drums, or in suitable bulk containers, in a cool, dry, well ventilated place. Drums are handled carefully to prevent puncturing. Precautions are taken in order to avoid water coming into contact with the material or packaging. Containers (cylinders, carboys) are made of stainless steel and steel-jacketed lead and road tankers are nickel-lined. Phenol resins are used as additional lining. Carbon steel is used for phosphorus trichloride, but not for phosphoryl chloride.

#### Achieved environmental benefits

- protection of the workers
- accident prevention
- prevention of spills.

#### Cross-media effects

- none.

#### Applicability

- generally applicable.

#### Example plants

- Thermphos, Germany
- LANXESS, Germany.

#### Reference literature

[3, UNEP, et al., 1989]

## 6.2.5 Best Available Techniques

Noting the introduction of BAT given in Chapter 5 and remembering that generic BAT for the SIC sector are also defined in Chapter 5, this section presents specific BAT conclusions generally applicable to the production of phosphorus compounds. Therefore, BAT for the production of phosphorus compounds is the combination of the generic elements presented in Chapter 5 and the specific elements indicated in this section.

### Raw material selection, storage and handling

BAT is to:

6.2.1 minimise the amount of waste generated in the process by using elemental phosphorus raw material containing low organic and inorganic impurities (see Section 6.2.4.4).

BAT is to:

6.2.2 reduce the consumption of energy required to melt the solid white/yellow elemental phosphorus raw material by using hot condensate water coming from other parts of the process (see Section 6.2.4.1).

Because elemental phosphorus raw material is flammable when in contact with air, BAT is to:

6.2.3 minimise the risk of fire by blanketing the elemental phosphorus raw material up to the reaction step with an inert medium. This can be done by either of the following techniques:

- using an inert gas like N<sub>2</sub> (see Section 6.2.4.2)
- using water as a blanket (see Section 6.2.4.3 above) and recycling the water for off-gas scrubbing.

### Choice of the production process

For new installations, BAT is to:

6.2.4 produce PCl<sub>3</sub> using a process that allows a reaction yield of over 99.5 % related to the use of phosphorus which is equivalent to a reaction yield of over 99.9 % related to the use of chlorine (see Sections 6.2.2.2.1.1 and 6.2.2.2.1.2).

### Prevention of accidents

BAT is to:

6.2.5 minimise spills and leakages of hazardous corrosive materials by using strictly enclosed systems for production (see Section 6.2.4.7).

BAT is to:

6.2.6 place warnings and information labels on all pipes and equipment (see Section 6.2.4.7).

### Emissions to air

BAT is to:

6.2.7 reduce HCl emissions to air from the production of phosphorus compounds and achieve emission levels of 3 – 15 mg/Nm<sup>3</sup> by alkaline scrubbing (see Section 6.2.4.6).  
To minimise emissions in all production conditions, flowrates through the scrubber system and alkali concentration in the scrubbing medium have to be sufficiently high.

### Emissions to water

BAT is to:

- 6.2.8 minimise emissions of phosphorus and chloride to the receiving water by treating water effluents in a WWTP equipped with biological treatment and achieve emission levels of P to the receiving water of 0.5 – 2 kg/t of raw elemental phosphorus and emission levels of Cl to the receiving water of 5 – 10 kg/t of raw elemental phosphorus (see Section 6.2.3.4).

### Waste

BAT is to:

- 6.2.9 achieve emission levels of distillation residues from  $\text{PCl}_3$  production to 4 – 8 kg/t of raw elemental phosphorus (see Section 6.2.3.5).

BAT is to:

- 6.2.10 incinerate distillation residues from  $\text{PCl}_3$  production (see Section 6.2.4.8).

## **6.3 Silicones**

### **6.3.1 General information**

‘Silicones’ are a special variety of polymers. Although they are partially organic in composition, silicone molecules differ from those of most polymers in that the backbone of their structure does not contain carbon, the characteristic element of organic compounds, but is a chain of alternating silicon and oxygen atoms, modified with various organic groups attached to the silicon atoms. In industrially important silicones, these groups are usually methyl or phenyl.

Polyorganosiloxanes is the scientific name for ‘silicones’.

Silicones have many outstanding properties. In general, methyl silicones exhibit greater stability to high temperatures, ultraviolet radiation, and weathering than organic polymers. They also generally exhibit good dielectric properties, as well as low temperature dependence of their physical properties.

Several thousands of different silicone products are on the market, and a production site often manufactures over a thousand different silicone products.

The SIC silicones addressed in this document concentrate on the most important silicone compound, namely polydimethylsiloxane (PDMS). There are also other important silicones, which are only briefly mentioned in this document.

### 6.3.1.1 Uses

Silicones are used for a very wide variety of applications. They are utilised as sealants, electric isolators, lubricants, elastomers (i.e. rubbers), water-resistant coatings or as additives in lacquers, paintings or cosmetic products.

Generally, the very large variety of silicone products can be broken down into five main product groups:

- intermediates
- fluids
- specialities (adhesives/abhesives, emulsions/antifoams, resins and paint additives for coatings, foam stabilisers, impregnating agents, and others)
- elastomers (Heat Cure Rubber – HCR, Liquid Silicone Rubber – LSR, Room-Temperature Vulcanisation – RTV – component)
- sealants.

From an end use point of view, the business of silicones comprises several thousands of micro-markets, depending on the specific application for which the silicones are used.

### 6.3.1.2 Toxicology and environmental aspects for the use of silicones

Unless otherwise specified, the following information derives from Ullmann's encyclopedia [1, Ullmann, 2001].

The toxicology of silicones, especially polydimethylsiloxanes (PDMS), has been thoroughly studied because silicones are used in medicine and medical technology, as well as in cosmetics.

The inertness of silicones towards warm-blooded animals has been demonstrated in a number of tests.

A panel of experts from the Food and Agriculture Organisation (FAO) and the World Health Organisation (WHO) considers the daily intake by human beings of 1.5 mg of PDMS per kilogram of body weight in the form of food additives to be unobjectionable.

In the case of organofunctional polysiloxanes, toxic effects cannot be excluded, because of the reactivity of the organofunctional groups. Polysiloxanes containing trifluoropropyl groups form toxic decomposition products when they are heated above 280 °C. The conditions of use take these properties into account.

Liquid and volatile siloxanes enter the environment as a result of use. Soil (sewage sludge) and sediment are sinks, and siloxanes are found in trace amounts in these environmental compartments. Siloxanes have no marked harmful effects on organisms in the environment. Siloxanes ultimately degrade to silica, carbon dioxide and water. Therefore, they are assumed not to represent an environmental hazard.

Volatile methyl siloxanes having negligible photochemical reactivity show, therefore, a negligible contribution to tropospheric ozone formation. However, methylchlorosilanes used to produce methyl siloxanes are substances that, if emitted to the air, would contribute to tropospheric ozone formation.



### 6.3.1.3 Production capacity

The production capacity of raw siloxanes (i.e. polydimethylsiloxanes or PDMS) in Europe is given in Table 6.16.

Location	Production capacity in 2004
Barry, United Kingdom	130000 tonnes of PDMS <sup>1</sup>
Roussillon, France	100000 tonnes of PDMS <sup>1</sup>
Burghausen, Germany	90000 tonnes of PDMS <sup>2</sup>
Leverkusen, Germany	75000 tonnes of PDMS <sup>1</sup>
Nünchritz, Germany	30000 tonnes of PDMS <sup>1</sup>
<sup>1</sup> 2002, from <i>Silicones</i> , CEH Marketing Research Report, SRI International 2003	
<sup>2</sup> 1999, from <i>Silicones</i> , CEH Marketing Research Report, SRI International 2000	

**Table 6.16: Production capacity of raw siloxanes (i.e. PDMS) in Europe**

### 6.3.1.4 Features of the European silicone industry

In Europe, four large enterprises (one producing at two sites) of over 250 employees manufacture silicones, in medium sized installations. Production is carried out in multipurpose plants using a continuous mode of operation. The workforce employed to run the silicone production facilities within these large enterprises, is between 120 and 200 persons. Production is carried out in installations that are part of a larger chemical complex where the raw chlorine material is produced.

### 6.3.1.5 Economics

In 2002, the global market for silicones totalled about EUR 8000 million, corresponding to a production volume slightly above two million tonnes. Between 1995 and 1998, the average global growth rate of silicone production was about 6 %, the major part of which can be attributed to growth in Asia.

In 2002, the main areas of silicones sales were in Europe (33 %) and in North America (34 %).

### 6.3.2 Applied processes and techniques

This section focuses on the production process of methylchlorosilanes as they are the most important chlorosilanes used industrially in the production of silicones. Methylchlorosilanes represent over 90 % of the total production of silicones [1, Ullmann, 2001].

Industrial silicone production has its commercial basis in the direct synthesis of methylchlorosilane via a process called the Müller-Rochow synthesis invented in 1942. In this process, methylchlorosilanes (a silane mixture from which the most important organochlorosilanes are derived) are synthesised by a reaction of elemental silicon with methyl chloride ( $\text{CH}_3\text{Cl}$ ) with the help of a copper catalyst.  $\text{CH}_3\text{Cl}$  is generated by reacting methanol ( $\text{CH}_3\text{OH}$ ) with hydrogen chloride ( $\text{HCl}$ ). The methylchlorosilanes are distilled to purify and separate the main reaction components, the most important of which being dimethyldichlorosilane. The hydrolysis (or methanolysis) of dimethyldichlorosilane, followed by polycondensation, leads to the formation of silicone polymers. European producers manufacture PDMS exclusively by a hydrolysis process. Methanolysis is mentioned here only because of historical interest. Another method used to synthesise  $\text{SiCl}_4$  and  $\text{HSiCl}_3$  is the (hydro)chlorination of Si. The main process steps are:

- reaction of  $\text{HCl}$  or  $\text{FeSi}$  in fixed bed reactor
- quenching and removal of solids from the reaction gas
- evaporation and distillation.

The production of silicones may be seen as a rather complicated production process, compared to other SIC production processes, involving many process steps (Figure 6.14). The main process steps in the production of silicones are:

- methyl chloride synthesis
- grinding of silicon
- direct synthesis (Müller-Rochow synthesis)
- distillation
- hydrolysis/condensation or methanolysis
- polymer synthesis (equilibrium polymerisation or polycondensation).

The first five process steps lead to the formation of **PDMS** that is further processed into thousands of silicone products in later process steps.

#### 6.3.2.1 Auxiliary chemicals and utilities

A number of auxiliary chemicals and utilities are used to support the production of silicones. These may include:

- nitrogen for inertisation of certain process steps and pumping of elemental silicon
- natural gas or fuel for steam production or thermal oil heating, and for the vent incinerator
- thermal oil for heat-transfer in the direct synthesis
- catalysts for fostering the reaction
- steam for heating
- electricity to power process equipment
- refrigerant liquids/gases for cryocondensation
- cooling water
- sulphuric acid
- sodium hydroxide or sodium carbonate.

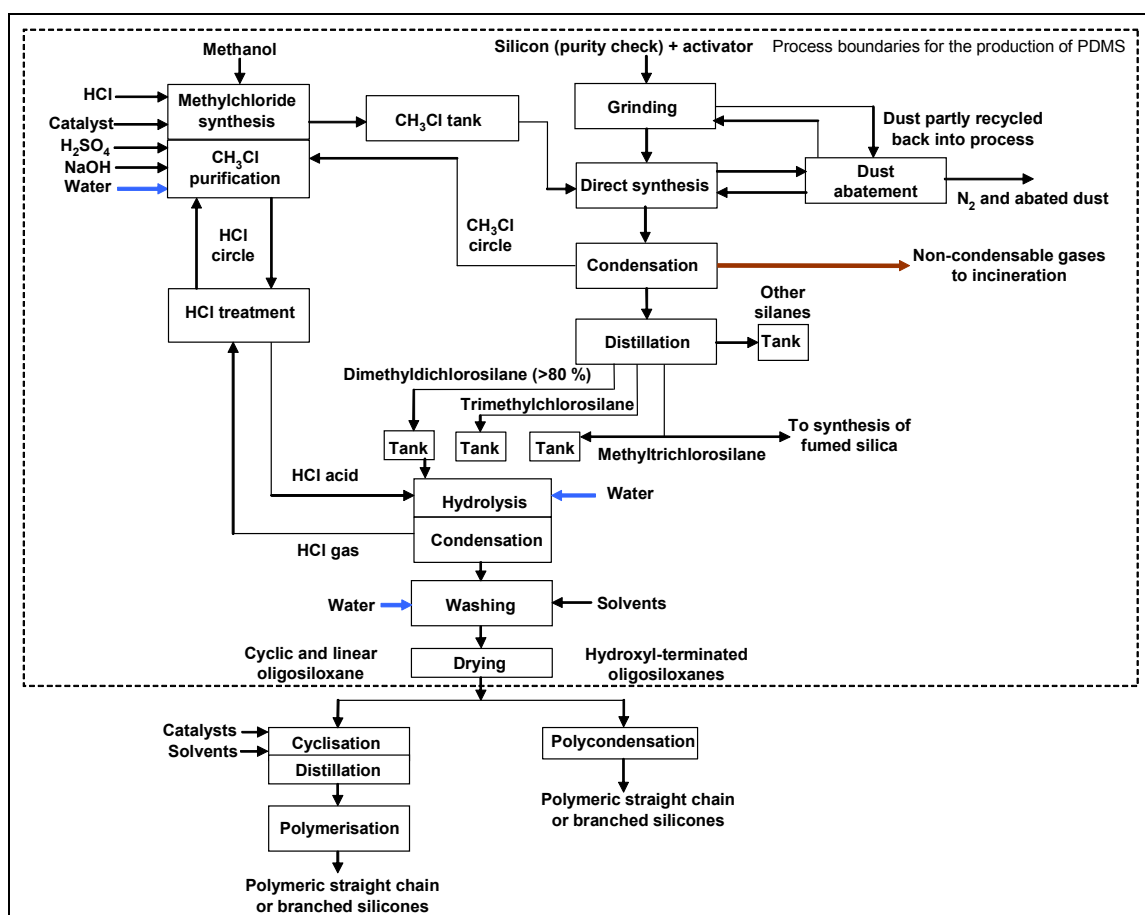

Figure 6.14: Process steps for the production of silicones

### 6.3.2.2 Raw materials and auxiliary chemicals storage and handling

The main raw materials for the production of silicones are elemental silicon, HCl, and methanol. Auxiliary chemicals used in the production of silicones include catalysts (e.g. copper catalyst in the direct synthesis), activators and solvents.

Elemental silicon (also called silicon metal) at greater than 98 % purity is delivered to the plant in pellets by trucks. The pellets are unloaded in a covered storage area or directly into a storage silo. Loaders or mechanical transport devices (e.g. bucket elevators) are used to take the elemental silicon from the loading area into the grinder. Once sieved to the appropriate size, the elemental silicon is stored and processed in a closed system under nitrogen.

Other solid raw materials (e.g. catalysts) are delivered on site in drums or other small packaging units.

All the liquid materials used in the production of siloxanes are stored in closed tanks and handled by closed piping systems (with nitrogen inertisation).

### 6.3.2.3 Methyl chloride synthesis

Methyl chloride ( $\text{CH}_3\text{Cl}$ ) is synthesised from methanol ( $\text{CH}_3\text{OH}$ ) and hydrogen chloride (HCl) in the gas phase or in the liquid phase (Figure 6.15). The catalyst used to foster the reaction may vary from one producer to another (e.g.  $\text{Al}_2\text{O}_3$ ,  $\text{ZnCl}_2$ ). The operating temperatures are normally 150 to 200 °C and the pressure range is from 2 to 3 bars. The hydrogen chloride used in this process step can be partly recovered from the hydrolysis process (see Section 6.3.2.7 below).

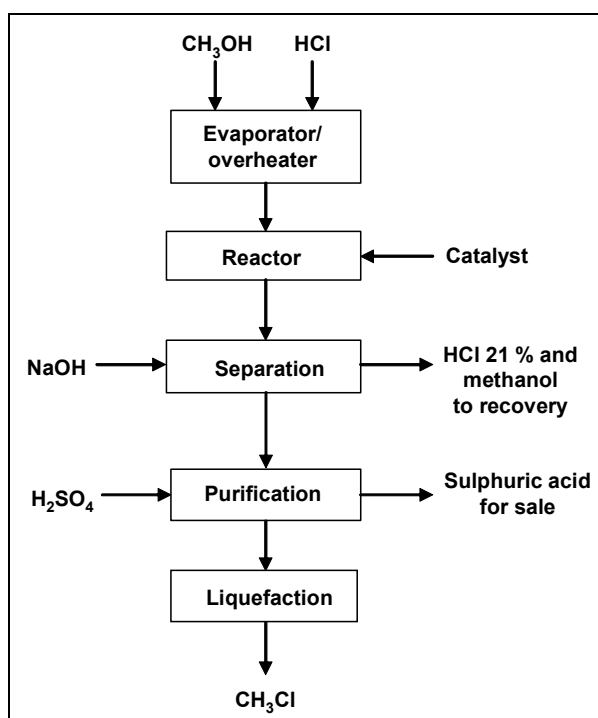

Figure 6.15: Methyl chloride synthesis

The conversion of methanol is nearly complete (98 – 99 %) in this reaction. A by-product is dimethylether. Unreacted hydrogen chloride (1 – 2 %) is discharged as hydrochloric acid together with the reaction water. HCl and, in some cases, unreacted methanol are recovered and recycled back into the process.

Remaining traces of hydrochloric acid vapour, water and a small volume of dimethylether is absorbed in sulphuric acid, which can be recovered by a sulphuric acid recovery plant.

The methyl chloride is then liquefied by cryocondensation, and sent to storage tanks to serve as feedstock for the direct synthesis. The cryocondensation is executed, e.g. with refrigerant liquids or gases. Alternatively, the methyl chloride can be compressed and liquefied by water condensation.

#### 6.3.2.4 Grinding of silicon

Silicon powder is an essential raw material in the production process of silicones. The technology of the direct synthesis operation determines the particle size of the elemental silicon powder. Therefore, the grinding unit usually includes a grinder and a sieve to control particle size distribution. Grinding is carried out in a low oxygen content atmosphere or by taking other special technical measures to prevent explosions.

#### 6.3.2.5 Direct synthesis

In the Müller-Rochow process, the elemental silicon powder reacts with methyl chloride in a fluidised-bed reactor (the main catalyst used is copper) to produce dimethyldichlorosilane (the yield of the reaction is typically >78 %) according to the following equation:

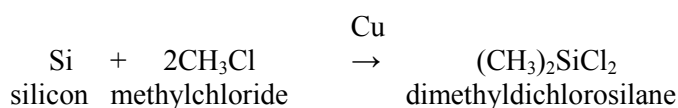

The operating temperatures are normally 280 – 330 °C. The impurities contained in the elemental silicon and the catalysts used heavily influence the performance of the chemical reaction. Details of the specifications for the elemental silicon and catalysts used are confidential.

The main by-products of the reaction are methyltrichlorosilane (5 – 12 %) and trimethylchlorosilane (2 – 4 %). Other by-products are methylhydrogendichlorosilane ( $\text{CH}_3\text{HSiCl}_2$ ), dimethylhydrogenchlorosilane ( $((\text{CH}_3)_2\text{HSiCl})$ ), tetramethylsilane, tetrachlorosilane, disilane, trisilane and silicon-free compounds.

The mixture of silicon, copper and other co-catalysts (detailed information on catalyst composition is confidential) is continuously fed into the fluidised-bed reactor along with superheated methyl chloride (liquid methyl chloride which has been evaporated before being superheated). The elemental silicon particle size is <1 mm, so that no product separation and no greater product emission takes place.

The gas coming out of the reaction is composed of dimethyldichlorosilane, of by-products and of unreacted methyl chloride. Cyclones and/or bag filters separate any dust (e.g. composed of a mixture of silicon, copper, impurities from silicon) carried out of the reactor, so that only gaseous substances can continue further along the process. The remaining residues from the separation are partly recycled back into the reactor (Figure 6.14).

The gaseous products which are free of dust pass through condensers in order to extract the unreacted methyl chloride which is then recycled back into the process (Figure 6.14). Most of the uncondensable gases (mainly nitrogen, light hydrocarbons and small quantities of methyl chloride) are incinerated on or off site.

The direct synthesis step is a net producer of energy which is recuperated and used particularly for the distillation step.

### 6.3.2.6 Distillation

The bulk of the methylchlorosilanes obtained are distilled in several columns to recover high purity methylchlorosilanes such as:

- dimethyldichlorosilane: 78 – 90 %
- methyltrichlorosilane: 5 – 12 %
- trimethylchlorosilane: 2 – 4 %
- methylhydrogenodichlorosilanes: 2 – 5 %
- dimethylhydrogenochlorosilanes: <1 %
- tetramethylsilane: <1 %
- tetrachlorosilane: <1 %.

Due to extremely high purity requirements, some of the separations are difficult and require columns with a large number of separation stages.

The separation of the methylchlorosilane mixture is energy intensive. The difference in boiling points between the two main products from the direct process, dimethyldichlorosilane and methyltrichlorosilane, is 4 °C.

In view of the highly reactive nature of chlorosilanes, which readily hydrolyse when in contact with water to form corrosive hydrochloric acid, the reaction is highly regulated and controlled and is designed to ensure process containment under normal operating conditions.

### 6.3.2.7 Hydrolysis/condensation or methanolysis

After separating the different products and by-products by distillation, dimethyldichlorosilane is hydrolysed to produce polydimethylsiloxane (PDMS). The chlorine atom in the methyl-chlorosilane is replaced by an OH-group, which is the basis for further condensation reactions to produce higher molecular weight siloxanes.

The complete hydrolysis of dimethyldichlorosilane leads to an oligomer mixture, consisting of cyclic dimethylsiloxanes and hydroxyl-terminated linear dimethylsiloxanes.

Complete hydrolysis with water, or a mixture of methanol and water, is carried out continuously in the liquid phase with saturated hydrochloric acid, or in the gas phase. Liquid-phase hydrolysis gives cyclic and linear oligomeric dimethylsiloxanes (the ratio depends on the hydrolysis conditions). The siloxane products which are insoluble in water, are separated and purified.

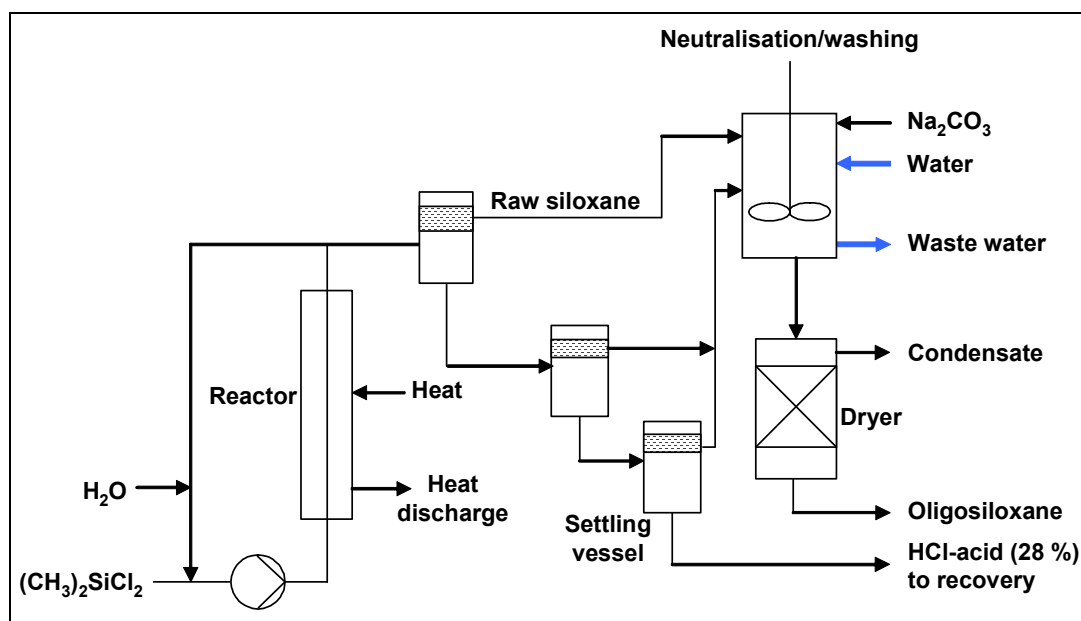

Figure 6.16: Example of the hydrolysis of dimethyldichlorosilane to oligosiloxane

Hydrolysis generates hyperazeotropic hydrochloric acid, which is recycled for recovering HCl. The gaseous hydrogen chloride which is generated can be used directly for the synthesis of methyl chloride.

The aqueous hydrogen chloride obtained in liquid phase reactions can be sold or recovered and re-used in the process depending on its quality. In most cases, recovery is only economical for large volumes. The recovery of gaseous hydrogen chloride from the hydrolysis of dimethyldichlorosilane is, for example, integrated into the hydrolysis process. HCl recovery is not economical for low production volumes. In these cases, hydrogen chloride is neutralised and discharged into the sewerage system.

### 6.3.2.8 Polymer synthesis

In the polymer synthesis, PDMS forms different polymeric structures depending on process conditions. Over 4000 different products can be manufactured at a given plant starting with raw PDMS.

Silicone polymers can be synthesised in two ways, depending on the end-product required:

- equilibrium polymerisation
- polycondensation.

#### 6.3.2.8.1 Equilibrium polymerisation

In the cyclisation reaction, equilibrium polymerisation is utilised to convert cyclic dimethylsiloxanes into polydimethylsiloxane polymer chains.

As the products from the hydrolysis process consist of both linear and cyclic siloxanes, the oligomeric mixture must be distilled or totally converted into cyclic molecule structures. This can be achieved by heating the hydrolysis mixture with potassium hydroxide or other catalysts in a solvent mixture. The catalysts promote an equilibrium reaction, in which the Si-O-Si bonds are cleaved and reformed (cyclisation).

As easily volatile cyclic dimethylsiloxanes are continuously distilled off, the equilibrium is shifted in a direction favouring the desired cyclic siloxane, so that all of the siloxane mixture is finally converted into cyclic dimethylsiloxane. Trifunctional impurities are retained.

From the mixture of simple cyclic organosiloxanes obtained, ultrapure octamethylcyclotetrasiloxane (D<sub>4</sub>) is distilled off, which can be used for polymerisation. Other cyclosiloxanes are recycled back into the equilibration process or placed on the market.

The polymerisation of D<sub>4</sub> can be executed either anionically or cationically. Anionic polymerisation with alkali-metal hydroxide, especially KOH, is of industrial importance. In the presence of KOH and water, the cyclic organosiloxanes are converted via an intermediate product, to linear hydroxyl-group terminated polydimethylsiloxane chains. After neutralisation of the mixture, the remaining cyclosiloxanes are separated by distillation. Other raw materials can be added to obtain functional polymers.

Cationic polymerisation of cyclosiloxanes is carried out with strong protonic or Lewis acids. An industrially important catalyst is sulphuric acid.

#### 6.3.2.8.2 Polycondensation

Whereas the preferred starting materials for equilibrium polymerisation are cyclic siloxanes, polycondensation is only possible with hydroxyl-terminated linear oligomers. The polycondensation reaction takes place at normal temperatures in the presence of an acid catalyst, e.g. phosphonitric chloride, and is completed by neutralisation. Polycondensation generates a small volume of reaction water, which is distilled off under a vacuum and is discharged as waste water.

Analogously to the manufacture of linear polysiloxanes on the basis of dimethyldichlorosilane, branched siloxanes can also be generated by the addition of tri- and tetrafunctional units. The viscosity of polysiloxanes significantly increases with increased branching. In some cases, solvents therefore have to be added to process these high viscosity fluids. These solvents must be recovered, as far as possible, from the manufacturing process. The kind of siloxane product obtained depends on the molecular weight and the number of branches and molecular networks. The main product groups are silicone fluids, resins, elastomers and emulsions.

### 6.3.3 Consumption and emission levels

#### 6.3.3.1 Raw materials, auxiliary chemicals, energy and water consumption

The consumption of raw materials, auxiliary chemicals, energy and water for the production of silicones is depicted in Figure 6.17. This figure shows the process boundaries of PDMS production. Inside these boundaries, the process steps are nearly the same in all European production plants. Due to the different silicone products (more than 4000), polycondensation and polymerisation have to be considered as individual process steps, which cannot be directly compared.

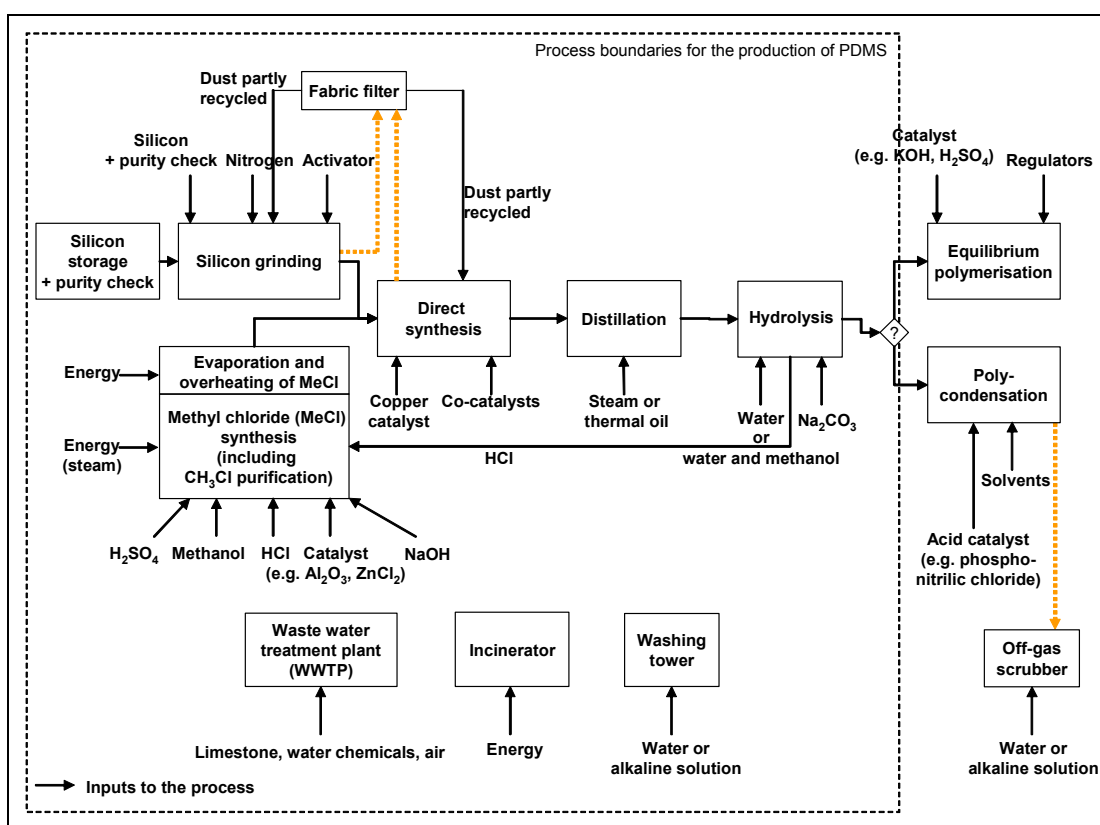

Figure 6.17: Consumption of raw materials, auxiliary materials, energy and water for the production of silicones

##### 6.3.3.1.1 Raw materials and auxiliary chemicals consumption

In the direct synthesis, 85 – 95 % of elemental silicon is converted into methylchlorosilane monomers, 78 – 90 % of which are dimethyldichlorosilanes. The hydrolysis reaction is almost quantitative. The HCl and methanol yield is >94 %. Catalyst consumption in the direct synthesis represents 1 – 4 % (by weight) of the elemental silicon consumption.

##### 6.3.3.1.2 Energy consumption

Energy sources used for the production of silicones are electricity, steam (1.2 bars, 6 bars, 10 bars and 30 bars) and natural gas.

Electricity is used to run pumps, compressors, agitators and other electric motors.

Direct synthesis is a net producer of energy which is recuperated and converted into steam used particularly for the distillation step.

Natural gas is mainly used to operate the vent incineration units.



Utility consumption for silane distillation is optimised by pinch methodology. The electricity consumption for PDMS production is about 23 – 30 MJ/kg PDMS. The steam consumption cannot be estimated because steam is provided by central units or recovered by internal heat exchange. Each plant site has its own unique solution for optimising energy consumption.

### 6.3.3.1.3 Water consumption

Water is used in the production of silicones for:

- washing waste gases in scrubbers
- hydrolysing dimethyldichlorosilane
- cleaning equipment
- cooling equipment
- washing PDMS.

Water volumes are measured for the whole manufacturing process down to the finished products. The usage of water is optimised.

The maximum specific consumption of process water is about 20 m<sup>3</sup>/t PDMS.

### 6.3.3.2 Air emissions

Emissions to air from the production of silicones are shown in Figure 6.18. The specific data provided refer to PDMS production which ends with hydrolysis. The polycondensation and polymerisation process steps are not included.

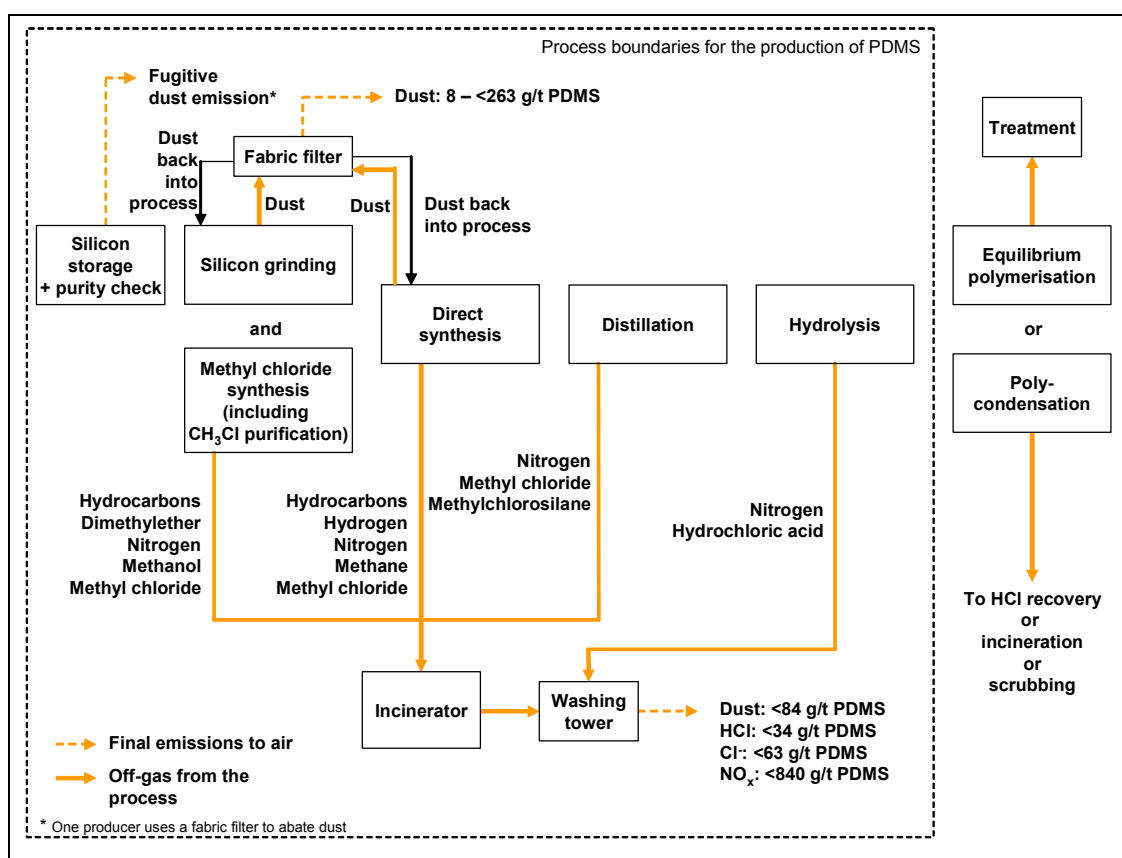

Figure 6.18: Emissions to air from the production of silicones

Stockpiles of raw materials (e.g. silicon) can be a source of diffuse dust emissions.

**Off-gas from elemental silicon grinding, storage and handling.** The dust-loaded off-gas streams from elemental silicon grinding, storage and handling are led to off-gas filters before being discharged into the air. The dust concentration in the treated off-gas streams is generally in the range of 8 – <263 g/t PDMS (which approximately corresponds to a range of 10 - 50 mg/Nm<sup>3</sup>. Industry prefers to use g/t PDMS instead of mg/Nm<sup>3</sup> because it gives comparable results – using mg/Nm<sup>3</sup> would not give comparable results between silicone producers because various amounts of nitrogen are used to convey elemental silicon). The filtered elemental silicon powder is recycled, e.g. back into the direct synthesis process.

**Off-gas from methyl chloride synthesis.** The off-gas stream from methyl chloride synthesis and the CH<sub>3</sub>Cl purification unit mainly consists of nitrogen (87 – 89 %) and dimethylether (10 %), methyl chloride (1 – 3 %), methanol and traces of hydrocarbon. Due to its composition, waste gas from methyl chloride synthesis and the CH<sub>3</sub>Cl purification unit is treated in an incineration unit. After incineration, the off-gas is purified in a washing tower, in some cases, under alkaline conditions to minimise emissions of dust and chlorinated species.

**Off-gas from direct synthesis.** The off-gas stream from direct synthesis mainly consists of nitrogen (70 – 80 %), methane (10 – 20 %), hydrogen (5 %), hydrocarbon (1 – 2 %) and methyl chloride (1 %). Due to its composition, waste gas from direct synthesis is led to an incineration unit.

**Off-gas from distillation.** The off-gas stream from the distillation step contains nitrogen, methyl chloride and methylchlorosilanes. Due to its composition, waste gas is led to an incineration unit or washed out with water.

**Off-gas from hydrolysis.** The off-gas stream from the hydrolysis process mainly contains nitrogen and hydrochloric acid. The off-gas stream is treated in a washing tower to eliminate hydrochloric acid.

**Off-gas from polycondensation.** The composition and volume of the off-gas streams from the polycondensation step in the production of high molecular linear or branched silicones can vary significantly. They depend on the desired silicone end-product, so that the following waste gas treatments are necessary, in order to minimise emissions:

- if the off-gas is loaded with HCl and traces of chlorosilane, HCl is recovered and recycled back into the process
- if the off-gas is strongly loaded with hydrocarbons (e.g. >5 %) and silanes (e.g. >5 %), it is led to an incineration unit
- off-gas streams with a low load of siloxanes and hydrocarbons are led to an off-gas scrubber. The resulting waste water is discharged into a waste water treatment plant.

### 6.3.3.3 Water emissions

Emissions to water from the production of PDMS are shown in Figure 6.19.

The main waste water sources from PDMS production are:

- methyl chloride synthesis
- direct synthesis
- hydrolysis/condensation with subsequent purification.

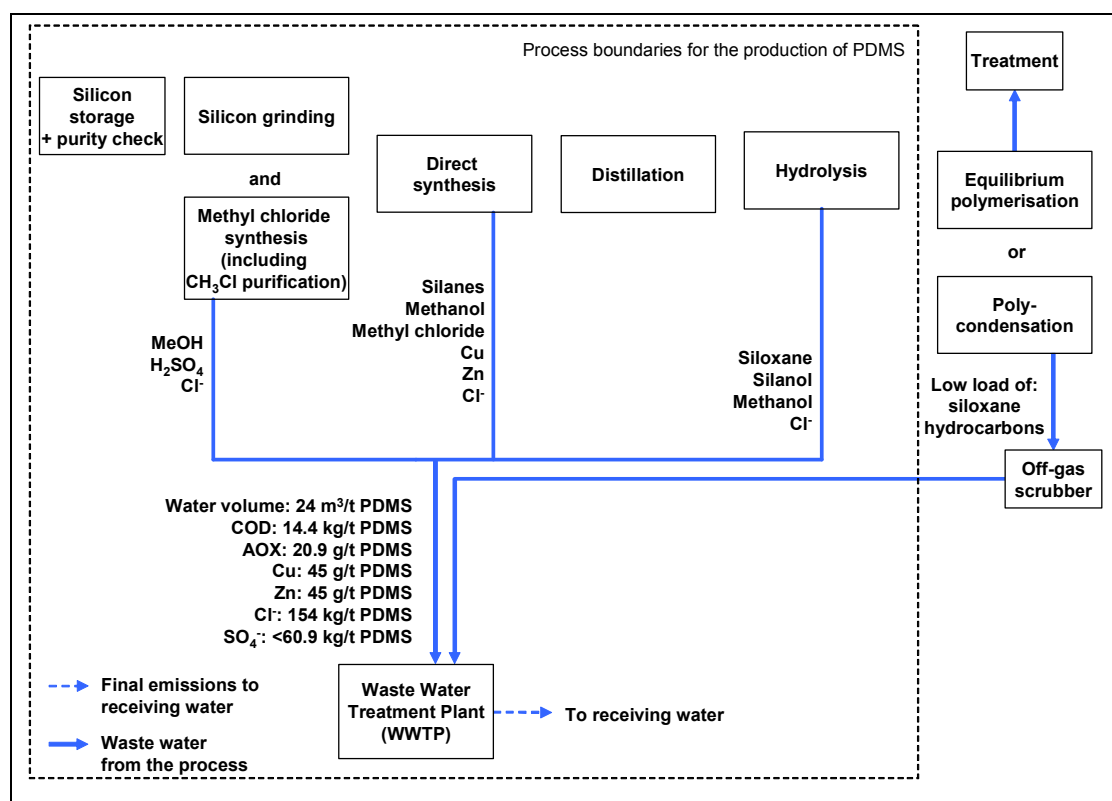

Figure 6.19: Emissions to water from the production of PDMS

**Note 1:** the specific data shown in Figure 6.19 regarding waste water emissions are maximum values of waste water volume and impurities before treatment and refers to PDMS production only (i.e. the polymerisation and polycondensation steps are not included).

**Note 2:** the data refer to the inflow stream to the WWTP.

**Note 3:** the waste water treatment is carried out in two steps: the waste water from PDMS production is pretreated by precipitation/flocculation followed by sedimentation to remove heavy metals and oils. After this pretreatment, the waste water is purified in a biological step together with water from other production processes. In one case, it is treated outside of the site boundaries in a municipal waste water treatment plant.

The main organic impurities present in the waste water from the direct synthesis step are siloxane, methanol and methyl chloride. The main organic impurities from hydrolysis and methyl chloride synthesis are siloxanes, silanol, and methanol. Inorganic impurities in waste water arise from the use of different catalysts and other additives. The main inorganic compounds present in the waste water are copper, zinc, chlorides, and sulphates.

Table 6.17 gives the typical copper and zinc concentrations after sedimentation.

Parameter	Concentration (mg/l)
Cu	<0.5
Zn	<2

Table 6.17: Metal concentrations after sedimentation

The waste remaining after sedimentation is a mixture of organic residues and metal compounds. The sludge is dewatered before disposal either via combustion or at a dedicated hazardous waste disposal facility.

The final purification of waste water takes place in a biological treatment plant, normally in combination with waste water from other manufacturing processes on site or with municipal waste water.

### 6.3.3.4 By-products and solid wastes

#### 6.3.3.4.1 By-products

Table 6.18 indicates the possible use of by-products from the production of silicones.

By-product	Process source	Possible use
H <sub>2</sub> SO <sub>4</sub>	Methyl chloride synthesis	External sales and internal use
Methyltrichlorosilane	Direct synthesis	External sales (e.g. synthesis of pyrogenic silica or specialised silicones) and internal use
Trimethylchlorosilane	Direct synthesis	External sales (e.g. synthesis of specialised silicones or hexamethyldisilazane) and internal use
Other silanes	Direct synthesis	External sales (e.g. for synthesis of specialised silicones or specialised silanes) and internal use
HCl	HCl treatment	Recycling in methyl chloride production and external sales

**Table 6.18: Possible use of by-products from the production of silicones**

#### 6.3.3.4.2 Wastes

Residues from **direct synthesis** contain siloxanes, elemental silicon and heavy metals.

The main residues from **hydrolysis** are siloxanes.

Residues from the chlorosilane **distillation** mainly contain hydrocarbons and chlorosilanes.

The amount of waste which is incinerated, landfilled or recycled outside of the process boundaries varies from one silicone installation to another. The total amount of waste produced at an installation is in the range of 46 – 313 kg/t PDMS. Such variations between installations are caused by:

- differences in process conditions
- differences in recycling inside the process boundaries
- local infrastructure (e.g. internal use of by-products in other production streams, central incineration, availability of waste site and disposal options)
- cost aspects.

Companies with a high level of recycling inside the process boundaries have the lowest waste volume, and therefore, by default, a lesser recycling level outside the process boundaries. Companies with a high waste volume are more likely to recycle outside of process boundaries.

#### 6.3.3.5 Noise

The main source of noise in the production of silicones comes from the grinding of elemental silicon and from compressors. Hooding of the grinder and compressors is a measure used to reduce noise level in the installation.

## 6.3.4 Techniques to consider in the determination of BAT

### 6.3.4.1 Storage of elemental silicon in silos

#### Description

Upon arrival at the site, elemental silicon is stored in silos or in covered areas, protected from wind and rain. After grinding, elemental silicon is always stored in silos.

One producer stores elemental silicon in storage hoppers and bag filters are used to minimise dust emissions during the loading of lump elemental silicon into the storage hopper. Another producer also uses a storage building besides the milling plant or takes over special shaped elemental silicon into storage silos.

#### Achieved environmental benefits

- reduction of diffuse elemental silicon dust emissions.

#### Cross-media effects

- none.

### 6.3.4.2 Optimisation of utility consumption by pinch methodology

#### Description

In the PDMS production process, electricity, steam (1.2 bars, 6 bars, 10 bars, 30 bars) and natural gas (mainly to run the vent incineration units) are used. The energy from the Müller-Rochow synthesis is converted, for example, into steam. Utility consumption for silane distillation is optimised by pinch methodology. Data from the analysis are confidential. Electricity is mainly used to run pumps, agitators and other electric motors.

For further information on Pinch methodology, please refer to Section 4.8.1.

#### Achieved environmental benefits

- reduction of utility consumption.

#### Cross-media effects

- none.

#### Reference literature

[18, European IPPC Bureau, 2004].

### 6.3.4.3 Dry dedusting system for elemental silicon grinding, storage and handling

#### Description

Filtration systems are used to reduce dust emissions to air from elemental silicon grinding, storage and handling. Fabric filters are generally used for this purpose. An example of a fabric filter system is shown in Figure 6.20.

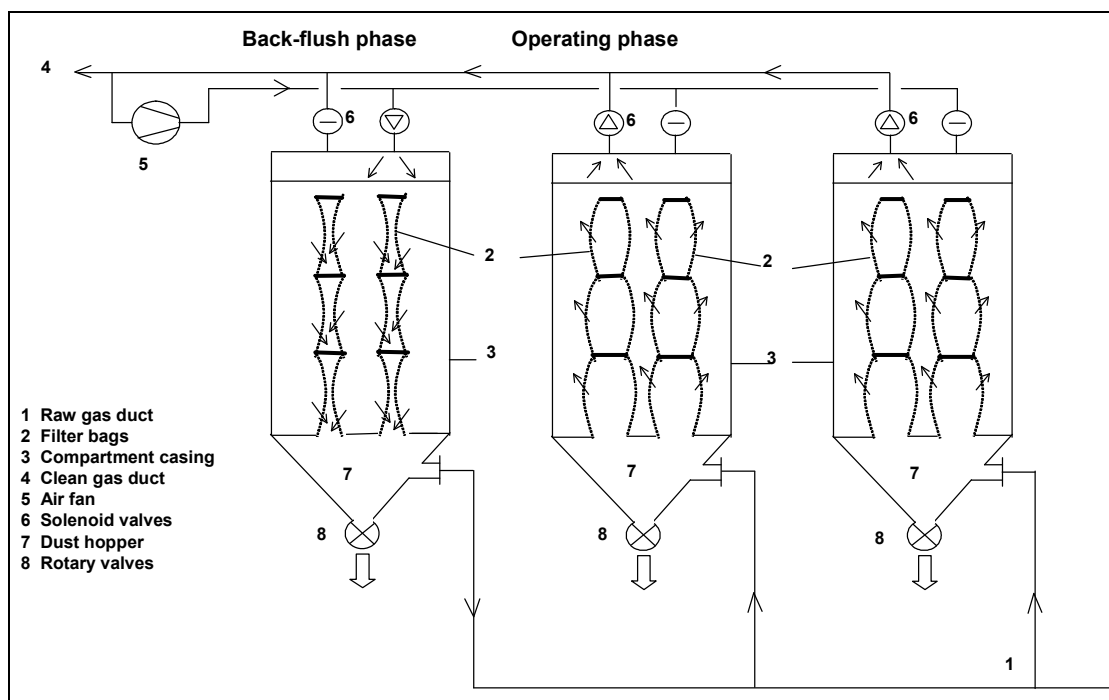

Figure 6.20: Example of a fabric filter system used in the production of silicones

Each silicone producer in Europe has between 5 to 20 fabric filters (usually one on each point source – e.g. silo, grinder) in its filtration system.

The dust separated is collected and recycled back into the process (direct synthesis).

A description of fabric filters is provided in the Reference Document on Best Available Techniques in Common Waste Water and Waste Gas Treatment/Management Systems in the Chemical Sector [21, European IPPC Bureau, 2003].

#### Achieved environmental benefits

- reduction of dust emissions to air
- reduction in raw elemental silicon consumption through the recycling of separated dust back into the process.

#### Cross-media effects

General information on cross-media effects associated with the use of fabric filters is presented in the Reference Document on Best Available Techniques in Common Waste Water and Waste Gas Treatment/Management Systems in the Chemical Sector [21, European IPPC Bureau, 2003].

### **Operational data**

Industry reported that one plant producing silicones achieved as low as 5 mg/Nm<sup>3</sup> by using fabric filters, but not consistently, and that 20 mg/Nm<sup>3</sup> is a fairly challenging emission level to reach (Germany indicated that a plant in Germany easily meets the 20 mg/Nm<sup>3</sup>). Industry indicated that fabric filters manufacturers cannot guarantee levels lower than 20 mg/Nm<sup>3</sup> due to the characteristics of the dust in silicones production (very fine and very abrasive dust). The majority of measurements made (one to three samples per year) show levels of between 5 and 20 mg/Nm<sup>3</sup> as well as higher levels of up to 50 mg/Nm<sup>3</sup> and even above.

The loading of the filters changes drastically during the production process.

The emission levels generally achievable with fabric filters are 2 – 10 mg/Nm<sup>3</sup> [21, European IPPC Bureau, 2003].

For more information on operational data associated with the use of fabric filters please refer to the Reference Document on Best Available Techniques in Common Waste Water and Waste Gas Treatment/Management Systems in the Chemical Sector [21, European IPPC Bureau, 2003].

### **Applicability**

General information on applicability is presented in the Reference Document on Best Available Techniques in Common Waste Water and Waste Gas Treatment/Management Systems in the Chemical Sector [21, European IPPC Bureau, 2003].

### **Economics**

General information on economics associated with the use of fabric filters is presented in the Reference Document on Best Available Techniques in Common Waste Water and Waste Gas Treatment/Management Systems in the Chemical Sector [21, European IPPC Bureau, 2003].

### **Driving force for implementation**

- local regulations.

### **Example plants**

- Rhodia Silicones at Roussillon, France.

### **Reference literature**

[21, European IPPC Bureau, 2003].

#### 6.3.4.4 Optimisation of the chemistry for the direct synthesis

##### Description

The catalyst system, reactor design and physical parameters for direct synthesis are optimised to minimise the formation of light hydrocarbons that are led to incineration. Details of such optimisations are producer specific and are, therefore, confidential.

##### Achieved environmental benefits

- reduction in the amount of waste sent to incineration
- reduction of fugitive VOC emissions.

##### Operational data

Chemistries used in direct synthesis is confidential information and operational data cannot, therefore, be provided.

#### 6.3.4.5 Recovery of methyl chloride through condensation with water heat exchangers

##### Description

At one plant, the off gas after distillation containing MeCl, N<sub>2</sub> and chlorosilanes is condensed before incineration, firstly through a water-cooled condenser and then through an ammonia-cooled condenser.

In another plant, water condensers maximise recovery of methyl chloride for re-use. The residual, non-condensed methyl chloride and inert gases (mainly nitrogen) pass to the incineration unit. This condensation technique is used as an industrial example in a good practice guide published by Envirowise in the UK.

##### Achieved environmental benefits

- reduction of methyl chloride emissions to the air
- reduction of consumption of raw methyl chloride through recovery and recycling back into the process.

##### Cross-media effects

- none known.

##### Operational data

Methyl chloride is compressed to about 6 bar to enable condensation with water. Operational details are confidential.



**Driving force for implementation**

Compliance with local regulations, economics and the statutes of the chemical industry's Responsible Care initiative.

**Example plants**

- Dow Corning, United Kingdom
- GE Bayer Silicones, Germany
- Wacker-Chemie GmbH, Germany.

**Reference literature**

www.envirowise.gov.uk; GG100 Solvent Capture and Recovery in Practice: Industry Examples.

**6.3.4.6 Recovery of methyl chloride through condensation using cryogenic fluids****Achieved environmental benefits**

- reduction of methyl chloride emissions to the air
- reduction of consumption of raw methyl chloride through recovery and recycling back into the process.

**Cross-media effects**

- none known.

**Driving force for implementation**

- regulatory compliance and economics.

**Example plants**

- Dow Corning, United Kingdom
- GE Bayer Silicones, Germany
- Rhodia, France
- Wacker-Chemie GmbH, Germany.

**Reference literature**

None known.

### 6.3.4.7 Condensation of methylchlorosilanes by air condensers

#### Description

Methylchlorosilanes are condensed by air condensers.

#### Achieved environmental benefits

- reduction of cooling water
- reduction of the risk that water enters methylchlorosilanes.

#### Cross-media effects

- none known.

#### Applicability

- generally applicable.

#### Example plants

- GE Bayer Silicones, Germany
- Wacker-Chemie GmbH, Germany.

#### Reference literature

- none known.

### 6.3.4.8 Thermal oxidation of off-gases containing light hydrocarbons and chlorinated organic compounds

#### Description

Off-gases containing light hydrocarbons and chlorinated compounds from the production of silicones are treated in a thermal oxidiser.

The thermal oxidiser must be authorised to burn chlorinated compounds. The amount of VOC, methyl chloride and chlorosilane emissions to the air are directly related to the reliability of the thermal oxidiser. To reduce chloride emissions, a scrubber is necessary after thermal oxidation.

#### Achieved environmental benefits

- reduction of VOCs (light hydrocarbons) emissions
- reduction of methyl chloride emissions
- reduction of chlorosilane emissions.

#### Cross-media effects

Thermal oxidation of chlorinated substances requires the use of fuels (e.g. natural gas), unless the chlorinated substances are incinerated together with other waste of proper fuel value.

#### Operational data

Data for emissions of individual substances (i.e. pollutants), in particular HCl, could not be derived as three out of four installations share end-of-pipe abatement equipment with other processes and waste streams that do not pertain to the SIC sector.

To avoid the formation of polychlorinated dibenzodioxins/furans (PCDD/F) when incinerating chlorinated compounds with a content of more than 1 % of halogenated organic substances, the following special operating conditions are considered appropriate. These conditions are indicated in several EU regulations on incineration, e.g. Directive 2000/76/EC on the incineration of waste:

- temperature >1100 °C (850 °C when incinerating waste with less than 1 % of halogenated organic substances)
- residence time >2 s
- oxygen content >3 %.

In addition, conditions that favour formation of dioxins/furans immediately following combustion are to be prevented. This is achieved by a 'fast-quench' of post-combustion gases by cooling them very quickly from high temperatures to below the temperature-window of dioxins/furans reformation.

These measures are designed to keep PCDD/F emissions below 0.1 ng TEQ/Nm<sup>3</sup>.

Waste gases are thermally oxidised with or without additional liquid or solid streams which may not be a part of PDMS production. These different feed stream compositions and technologies used result in different air discharge parameters and corresponding discharge concentrations.

One PDMS producer typically runs its thermal oxidiser at 1150 °C. The waste gas generally provides enough energy to achieve such an operating temperature with little or no supplementary fuel being required. To operate at lower temperatures would require additional energy in the form of cooling. Other producers operate at lower temperatures, e.g. 850 °C due to the co-incineration of waste (solids and/or liquids). Operating at higher temperatures than this could require additional heat energy.

### **Applicability**

- generally applicable.

### **Driving force for implementation**

- local regulations.

### **Example plants**

- Wacker-Chemie GmbH, Germany
- GE Bayer Silicones, Germany
- Dow Corning, United Kingdom
- Rhodia, France.

### **Reference literature**

WI BREF [34, European IPPC Bureau, 2004].

### 6.3.4.9 Treatment of waste water from PDMS production

#### Description

Certain metals are used as catalysts in the direct synthesis step (the specific catalyst systems are confidential). Traces of these metals are carried out in the water effluents coming from the following distillation step.

The waste water from PDMS production is treated in two steps: the waste water is pretreated by precipitation/flocculation followed by sedimentation to remove heavy metals. After this pretreatment, the waste water is purified in a biological step (on-site or off-site at a municipal waste water treatment plant).

In the pretreatment step, the soluble heavy metal ions present in the waste water from PDMS production (e.g. Zn, Cu, Al) are converted into insoluble metal complexes by precipitation through the addition of e.g. calcium hydroxide ( $\text{Ca}(\text{OH})_2$ ). The pH of the solution has to be brought to a suitable level allowing the soluble heavy metal ions present in the waste water to precipitate out of the solution. The pH should be between 8 to 10. It has to be noted that Zn and Al are amphoteric substances and therefore necessitate for precipitating to maintain the pH in a determined range. Flocculants are used to aid the precipitation process.

The liquid/solid mixture passes to a clarifier which enables the solids to settle by gravity (sedimentation) prior to removal at the base of the clarifier. The removed solids (consisting of calcium and metal salts) are then dewatered using a filter prior to being sent for landfill or incineration disposal. Some solid residues can build up in the feed tank to the water treatment over time (years). These residues are periodically (~ every four years, taking advantage of the maintenance inspection of the tank) removed and sent to landfill or incineration. The sedimented sludge is a mixture of organic residues and metal compounds, which, after dewatering is sent for disposal to an incinerator or to a hazardous waste landfill.

Unless the effluents containing organics were separated before being treated with lime, making further biological treatment unnecessary, the clarified effluent passes to a biological treatment process where micro-organisms (or biomass) are mixed with the effluent in a bioreactor to consume organic material present. As the biomass digests the organic material in the effluent, carbon dioxide is produced and this is absorbed into the water as carbonic acid which reduces the pH of the final effluent stream. Air or oxygen is fed to the bioreactor to keep the biomass active. The effluent overflows from the bioreactor into a clarifier where the biomass settles out and is returned to the bioreactor. The clarified water passes through a filter to remove residual solids as the final treatment step. The sludge is either incinerated, landfilled or sent to metal recovery plants.

#### Achieved environmental benefits

- reduction of the TOC content in the discharged water
- reduction of the heavy metals content in the discharged water.

#### Cross-media effects

- consumption of chemicals for precipitation/flocculation (e.g. calcium hydroxide)
- consumption of energy
- the precipitation/flocculation step produces sludges that need to be disposed of.

### **Applicability**

- generally applicable. Sodium hydroxide can be used as a precipitation agent, but may not be cost effective.

### **Example plants**

- GE Bayer Silicones, Germany
- Dow Corning, United Kingdom
- Wacker-Chemie GmbH, Germany
- Rhodia, France.

### **6.3.4.10 Minimisation of the quantity of water used in the production process**

#### **Description**

Volumes of cooling and process water are measured for the whole manufacturing process down to the finished goods. The usage of water is optimised. Whenever possible and economically justified, heat exchangers are built as air condensers.

#### **Achieved environmental benefits**

- reduction of the TOC and Cl content in the discharged water
- reduction of waste water.

#### **Cross-media effects**

- none known.

#### **Applicability**

- generally applicable.

#### **Driving force for implementation**

- cost reduction.

#### **Example plants**

- GE Bayer Silicones, Germany.

#### **Reference literature**

- none known.

### 6.3.4.11 Re-use of the water formed in the methyl chloride synthesis step into the hydrolysis step

#### Description

The water formed in the methyl chloride synthesis step can be re-used in the hydrolysis step.

#### Achieved environmental benefits

- reduction in the amount of waste water generated in the production
- reduction in consumption of fresh water in the hydrolysis step.

#### Cross-media effects

- none known.

#### Applicability

Because trace levels of methanol are present in the water formed in the methyl chloride synthesis step and can result in methoxy end-blocking on linear PDMS siloxanes, re-use of the water in the hydrolysis step is applicable only if the indicated effect on the end-products is tolerated by the customers.

#### Driving force for implementation

- economics.

#### Example plants

- GE Bayer Silicones, Germany
- Wacker-Chemie GmbH, Germany.

#### Reference literature

- none known.

### 6.3.4.12 HCl recovery from the hydrolysis of dimethyldichlorosilane

#### Description

HCl is recovered from the hydrolysis of dimethyldichlorosilane and used in methyl chloride synthesis.

#### Achieved environmental benefits

- reduction of HCl consumption in methyl chloride synthesis.

#### Applicability

HCl recovery is not economical for small production volumes. In these cases, hydrogen chloride is neutralised and discharged into the sewerage system.

#### Driving force for implementation

- cost aspects.

#### Example plants

- Wacker-Chemie GmbH, Germany
- Dow Corning, United Kingdom
- GE Bayer Silicones, Germany.

#### Reference literature

- none known.



### 6.3.4.13 Selection of the elemental silicon particle size

#### Description

The elemental silicon particle size is <1 mm to achieve maximum efficiency (i.e. reaction yield) of the chemical reaction in direct synthesis. Data on the exact particle size used are considered to be confidential.

#### Achieved environmental benefits

- high efficiency with a small elemental silicon loss as waste.

#### Cross-media effects

- none known.

#### Driving force for implementation

- increase of process yield.

#### Example plants

- Wacker-Chemie GmbH, Germany.

#### Reference literature

- none known.

#### **6.3.4.14 Use of a covered elemental silicon storage**

##### **Description**

Storage of elemental silicon before grinding is carried out in a covered area.

##### **Achieved environmental benefits**

- reduce diffuse emissions of elemental silicon to the air.

##### **Cross-media effects**

- none known.

##### **Applicability**

- generally applicable.

##### **Driving force for implementation**

- local regulations.

##### **Example plants**

- Dow Corning, United Kingdom
- Wacker-Chemie GmbH, Germany.

##### **Reference literature**

- none known.

### 6.3.4.15 Minimise the source of ignition energy from elemental silicon grinding

#### Description

Installation of a magnetic sorting system allows the capture of metallic parts upstream of the grinder.

Installation of antistatic blades on the bucket elevator limits the accumulation of static electricity.

#### Achieved environmental benefits

- reduced risk of fire with subsequent environmental impact.

#### Cross-media effects

- none known.

#### Driving force for implementation

- fire safety.

#### Example plants

- Rhodia, France.

#### Reference literature

- none known.

### **6.3.4.16 Minimise the sources of explosions from elemental silicon grinding and conveying**

#### **Description**

The concentration of oxygen and/or elemental silicon dust in the equipment (e.g. grinder, conveyor) atmosphere is permanently maintained at a safe level below the LEL. A safe oxygen level for elemental silicon is about 5 %, depending on the silicon particle size. The oxygen content is continuously monitored and alarms are reported to the control room. The grinder is automatically shut down in the cases where there is a high content of oxygen.

Pneumatic transport of ground elemental silicon is carried out in an inert gas (e.g. nitrogen) atmosphere.

The grinding unit is maintained at a slightly higher pressure than atmospheric pressure, in order to prevent air inlet. The grinding plant can also be run at less than atmospheric pressure to reduce the potential of diffuse dust elemental silicon emissions from occurring.

Any nitrogen supply breakdown in the grinding unit would trigger the shut down of the unit.

#### **Achieved environmental benefits**

- reduced risk of explosions with subsequent environmental impact.

#### **Cross-media effects**

- none known.

#### **Applicability**

- generally applicable.

#### **Driving force for implementation**

- explosion safety.

#### **Example plants**

- Rhodia, France.

#### **Reference literature**

Directive 94/9/EC of 23 March 1994 on the approximation of the laws of the Member States concerning equipment and protective systems intended for use in potentially explosive atmospheres (also called the ATEX directive).

Directive 1999/92/EC of 16 December 1999 on minimum requirements for improving the safety and health protection of workers potentially at risk from explosive atmospheres.

#### 6.3.4.17 Cooling of the distillation columns with air

##### Description

Organochlorosilanes are very sensitive to hydrolysis, that is, they react readily with water and vigorously give off hydrochloric acid. For safety reasons in the case of leaks, the distillation columns are usually not cooled with water but with air [7, Dr. Held, 2003].

##### Achieved environmental benefits

- reduction in the risk of accidents with subsequent environmental impact.

##### Cross-media effects

- none known.

##### Applicability

- generally applicable.

##### Driving force for implementation

- safety.

#### 6.3.4.18 Backup power source for the waste water treatments

##### Description

An automatic backup power source for waste water treatments can be installed.

Alternatively, it is possible to have adequate storage volume containment for untreated water in the event of power failure.

##### Achieved environmental benefits

- limits of the risks of accidental spills.

##### Cross-media effects

- none known.

##### Reference literature

US Environmental Protection Agency (EPA) report.

### 6.3.5 Best Available Techniques

Noting the introduction of BAT given in Chapter 5 and remembering that generic BAT for the SIC sector are also defined in Chapter 5, this section presents specific BAT conclusions generally applicable to the production of silicones. Therefore, BAT for the production of silicones is the combination of the generic elements presented in Chapter 5 and the specific elements indicated in this section.

#### Raw materials selection, storage, handling and preparation

BAT is to:

- 6.3.1 minimise diffuse dust emissions from the storage and handling of the elemental silicon raw material by applying a combination of the following techniques (see Section 6.3.4.1):
- storing elemental silicon in silos
  - storing elemental silicon in covered areas protected from rain and wind
  - using equipment designed with hooding and ducting to capture diffuse dust emissions during the loading of elemental silicon into storage
  - maintaining the atmosphere of the grinder at a slightly lower pressure than atmospheric pressure.

To achieve maximum efficiency (i.e. reaction yield) of the chemical reaction in the direct synthesis, BAT is to:

- 6.3.2 use elemental silicon raw materials with particle size <1 mm (see Section 6.3.4.13).

BAT is to:

- 6.3.3 reduce dust emissions from elemental silicon grinding, storage and handling, and achieve emission levels of 5 – 20 mg/Nm<sup>3</sup> (yearly average) by using fabric filters and recycling the separated dust back into production (see Section 6.3.4.3).

BAT is to:

- 6.3.4 minimise the amount of the methyl chloride raw material used by recovering methyl chloride contained in the off-gases from the distillation step (see Sections 6.3.4.5 and 6.3.4.6).

For large production volumes, BAT is to:

- 6.3.5 minimise the amount of HCl raw material used in the methylchloride synthesis step by recovering HCl from the hydrolysis step (see Section 6.3.4.12).

#### Chemistry of the direct synthesis

BAT is to:

- 6.3.6 minimise the amount of waste generated in the production process by optimising the chemistry of the direct synthesis. This includes all of the following (see Section 6.3.4.4):
- optimising the catalyst system
  - optimising the reactor design
  - optimising the physical parameters.

BAT is to:

- 6.3.7 maximise the use of by-products generated in the production of silicones (see Section 6.3.3.4). Table 6.18 indicates the possible use of by-products.

### Prevention of accidents

If a bucket elevator is used to charge the grinder, BAT is to:

- 6.3.8 minimise the sources of ignition energy from elemental silicon grinding (see Section 6.3.4.15), e.g. by having antistatic blades installed on the elevator to limit the accumulation of static electricity.

In order to minimise the risk of accidents and the subsequent environmental impact, BAT is to:

- 6.3.9 minimise the sources of explosions from grinding and conveying elemental silicon by maintaining the oxygen and/or elemental silicon dust content in the equipment atmosphere at a safe level below the LEL, for example by applying a combination of the measures below (see Section 6.3.4.16). A safe oxygen level for elemental silicon is about 5 %, depending on the silicon particle size:
- a. using nitrogen gas injection or continuous dust extraction
  - b. continuously monitoring the oxygen content in the atmosphere of the grinder and reporting alarms to the control room
  - c. carrying out pneumatic transport of ground elemental silicon under an inert gas atmosphere
  - d. tripping the grinder in case of breakdown of the inert gas supply.

In order to reduce the risk of accidents and the subsequent environmental impact, BAT is to:

- 6.3.10 cool the distillation columns with air (see Section 6.3.4.17).

### Energy

BAT is to:

- 6.3.11 reduce the consumption of energy by recycling the energy produced in the direct synthesis, e.g. for the distillation step (see Section 6.3.3.1.2).

### Waste gas treatments

BAT is to:

- 6.3.12 minimise emissions of VOCs (light hydrocarbons) and chlorinated compounds to air by thermal oxidation of the off-gases from the methyl chloride, direct synthesis and distillation process steps. This should be followed by scrubbing (see Section 6.3.4.8).

In general it is BAT to use the operating conditions (i.e. temperatures, residence time and turbulence) as specified in Article 6 of Directive 2000/76/EC. The use of operating conditions in excess of those that are required for efficient destruction of the VOCs (light hydrocarbons) and chlorinated compounds should generally be avoided. The use of other operating conditions may also be BAT – if they provide a similar or better level of overall environmental performance. For example, where the use of operational temperatures of below 1100 °C (as specified for certain hazardous waste in 2000/76/EC) have been demonstrated to provide a similar or better level of overall environmental performance, the use of such lower temperatures is considered to be BAT.

### Waste water treatment/management

BAT is to:

- 6.3.13 minimise the consumption of water by applying all of the following (see Sections 6.3.4.10 and 6.3.4.11):
- a. measuring volumes of cooling and process water for the whole manufacturing process down to the finished goods
  - b. optimising the usage of water
  - c. using air-cooled condensers instead of water cooled condensers where technically and economically justified
  - d. re-using water generated in the methylchloride synthesis step into the hydrolysis step provided any resulting changes to the product quality can be tolerated.

For waste water treatment, BAT is to:

- 6.3.14 minimise emission of Cu and Zn to water by pretreating the water effluents from PDMS production by precipitation/flocculation under alkaline conditions followed by sedimentation and filtration (see Section 6.3.4.9). This includes
- a. dewatering sludge before disposal and
  - b. recovering solid metal residues in metal recovery plants or
  - c. disposing of sludge via incineration or landfill.

BAT is to:

- 6.3.15 reduce BOD/COD content of the water effluent coming out of the pretreatment by applying a biological step (see Section 6.3.4.9).

BAT is to:

- 6.3.16 minimise the risk of accidental spills in the event of a power failure by applying either of the following techniques (see Section 6.3.4.18):
- a. providing an automatic backup power source for waste water treatments
  - b. providing adequate storage volume containment for untreated waste water.



## 6.4 Speciality inorganic chemical (SIC) explosives

[15, Castresana, 2004] [1, Ullmann, 2001]

The explosive substances considered in this section are limited to those that are produced by chemical processing and that meet the definition of Speciality Inorganic Chemicals given in the Scope section of this document. Inorganic explosives produced by non-chemical processes (i.e. physical processes such as the mixing of materials) are not addressed in this document.

Inorganic explosives are classified as 'primary explosives' [1, Ullmann, 2001] whose main function is to produce a shock wave when the explosive is stimulated electrically, optically or by percussion, thus initiating a 'secondary explosive'. Primary explosives are extremely sensitive (e.g. to shock, friction, heat, electricity, radiation), mostly in high purity forms, and can initiate their decomposition with very little external energy making their transport very difficult. This is why end user products containing these substances (e.g. detonators) are, therefore, produced at the very same locations where these substances are manufactured.

Organic explosives are classified as 'secondary explosives' and represent active ingredients used in energetic products such as dynamites and smokeless powders. The production of organic explosives is addressed in the Reference Document on Best Available Techniques for the manufacture of Organic Fine Chemicals [18, European IPPC Bureau, 2004].

The Speciality Inorganic Chemical (SIC) explosives that are of industrial and economic importance in Europe are **lead azide**, **lead trinitroresorcinate** (also called lead styphnate), and **lead picrate**. Lead trinitroresorcinate seems more used than lead azide, mainly for the initiation of pyrotechnic safety devices and for primer caps for hunting ammunition (probably more than 100 t/yr in Europe).

Figure 6.21 provides the chemical structure of these explosives. It should be noted that some SIC explosives are not strictly inorganic compounds and may have an organic content. They are nevertheless considered SIC substances for the purpose of this document because they are produced using inorganic chemistry.

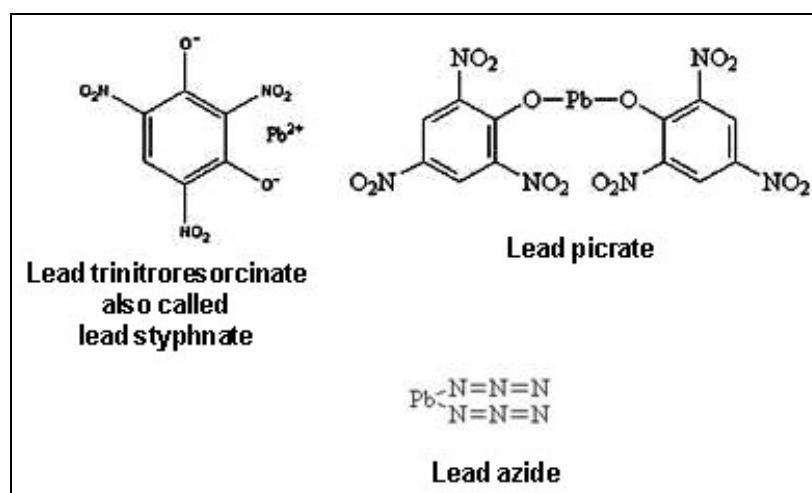

Figure 6.21: Chemical structure of some primary explosives

### 6.4.1 General information

**Lead azides** are white or yellow clear crystalline solids slightly soluble in hot water and in alcohol, and highly soluble in a diluted solution of nitric or acetic acid in which a little sodium nitrate has been dissolved.

**Lead trinitroresorcinates** are yellow to dark brown crystalline solids soluble in hot water and nitric acid. They have only a low solubility in ethanol and acetone, and are insoluble in ether, benzene, toluene, and hydrochloric acid.

**Lead picrates** are yellow to dark brown needled crystalline solids insoluble in water, and soluble in nitric acid and hydrochloric acid.

#### 6.4.1.1 Uses

Speciality Inorganic Chemical (SIC) explosives are active ingredients extensively used in the initiation of other explosive products such as dynamites and smokeless powders. Other uses include initiators in ammunition, detonators, propellants (to propel rockets and missiles) and pyrotechnics. SIC explosives are also used in air-bag inflators and seat-belt pretensioners.

Table 6.19 presents the main applications of SIC explosives.

SIC explosive	Main applications
Lead azide	Initiation of secondary explosives for civil or military uses
Lead trinitroresorcinate	Initiation of deflagrating products such as gun powders, propellants, fireworks, pyrotechnics and in air-bag inflators and seat-belt pretensioners
Lead picrate	Initiation of deflagrating products as gunpowders, propellants, fireworks, pyrotechnics and in air-bag inflators and seat-belt pretensioners

**Table 6.19: Main applications of SIC explosives**

#### 6.4.1.2 Toxicity

Lead azide, lead trinitroresorcinate and lead picrate have been classified as ‘dangerous substances’ under Council Directive 67/548/EEC on classification, packaging and labelling of dangerous substances. It should be noted that some new products, which are less toxic than lead compounds, are under experimentation in several countries to serve as primary explosives.

### 6.4.1.3 Production capacity

The reported production capacity of **lead azide**, **lead trinitroresorcinate** and **lead picrate** in Europe is given in Table 6.20.

Location (city, country)	Production capacity in 2004
Troisdorf, Germany	Lead azide Lead trinitroresorcinate
Rivalta, Italy	~20 t lead trinitroresorcinate
Galdácano, Spain	<15 t lead azide <10 t lead trinitroresorcinate
Vsetin, Czech Republic	<5 t lead azide <5 t lead trinitroresorcinate <300 kg lead picrate
Clérieux, France	~25 t lead trinitroresorcinate
Héry, France	<5 t lead azide <5 t lead trinitroresorcinate
Survilliers, France	<5 t trinitroresorcinate
Tarbes, France	~1 t lead azide ~1 t lead trinitroresorcinate
La Ferté-Saint-Aubain, France	<1 t lead azide <1 t lead trinitroresorcinate

**Table 6.20: Production capacity of lead azide, lead trinitroresorcinate and lead picrate in Europe**

It should be noted that other European producers exist in Italy, Germany, Portugal and probably in Sweden, Austria and Poland [40, ZANTE, 2004].

Less than 25 tonnes of SIC explosives (lead azide and lead trinitroresorcinate) are produced in Spain and Portugal every year compared to a total production of 95000 tonnes of explosives (both ‘primary’ and ‘secondary’ explosives) in these two countries, most of which are of organic nature.

In France, total production capacities are way over effective production (50 to 100 kg/day production at each installation).

Because SIC explosive substances are extremely sensitive (i.e. easily ignited or detonated) and, therefore, dangerous to transport, articles made with SIC explosive substances (e.g. detonators, blasting caps, initiating systems for pyrotechnics and propellants), that are designed to be safe in storage, transport and use, are manufactured at the very same site as the SIC explosive substances.

### 6.4.1.4 Features of the European SIC explosive industry

In Europe, large enterprises (over 250 employees) and medium sized enterprises (between 50 and 249 employees) manufacture SIC explosives. The workforce employed to run SIC explosive production facilities within these companies is generally below 20. Production is carried out batch wise in sites where production and storage buildings are scattered as a safety measure. In Spain, production is carried out in installations that are part of a larger explosive manufacturing complex where secondary explosives are produced. In France, production is carried out in plants that are dedicated to the production of initiating devices.

### 6.4.1.5 Economics

Economical data and product prices are usually not publicly available in the explosives industry.

For SIC explosives that are used as initiating charges for organic explosives and blasting agents, production figures follow those of these secondary explosives. Therefore, as the production figures of secondary explosives have remained nearly constant for the last few years, or are slightly declining, the production figures for the SIC substances used as initiating systems have remained constant. As the two major applications of explosives are in civil works and mining, it is important to point out that, at the time of writing, mining is declining in Europe and civil works (mainly road and tunnel construction) is the only market with a significant growth rate in some Member States.

For SIC explosives that are used in the automotive industry (mainly lead trinitroresorcinate), production has significantly increased during the past ten years. However, Directive 2000/53/EC on end-of-life vehicles forbids the use of lead compounds after 1 July 2007, so production should greatly decrease after that date.

SIC explosives (lead trinitroresorcinate) are widely used as the main component of primer caps for hunting and sporting ammunition. This market is slightly declining, and new products without lead (e.g. 2-Diazo-4,6-Dinitrophenol, mercuric-5-nitrotetrazole) are now starting to be investigated but are not commercially available yet.

The final customers do not buy SIC explosives directly, but indirectly in the products or devices using them (i.e. primer or percussion caps, squibs, detonators, pyrotechnic devices, etc.) and sometimes buy them as separate products. In other cases, SIC explosives are bought as part of a more complete supply or service, so it is very difficult to provide general features about competition or structure of the market for SIC explosives.

### 6.4.2 Applied processes and techniques

The following operations are carried out in the production of SIC explosives:

- raw materials solution
- reaction
- purification
- drying (not systematically, see Section 6.4.2.6).

Building floors where these operations are carried out are liquid tight in order to contain any spill and to avoid pollution of the soil by lead compounds.

#### 6.4.2.1 Process chemistry

**Lead azide** is produced by the reaction of lead nitrate (solid) and sodium azide (solid) in stoichiometric proportions through the following reaction:

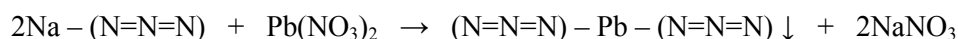

Sodium azide is produced industrially by the reaction of liquid sodium with liquid ammonia, followed by the addition of nitrous oxide to give sodium azide and sodium hydroxide. Sodium azide used in European SIC explosives manufacturing installations is imported from non-European countries.

**Lead trinitroresorcinate** is produced by the reaction of lead nitrate (solid), magnesium oxide (solid) and trinitroresorcine (solid) through the following reactions:

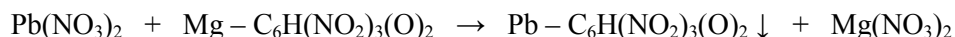
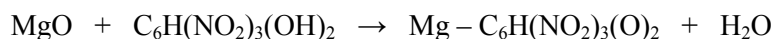

**Lead picrate** is produced by the reaction of lead nitrate –  $\text{Pb}(\text{NO}_3)_2$ , sodium picrate and acetic acid ( $\text{CH}_3\text{COOH}$ ) through the following reaction:

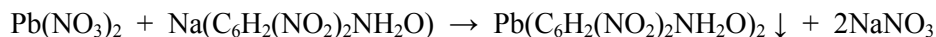

#### 6.4.2.2 Raw materials and auxiliary chemicals storage and handling

Raw materials are stored under cover (inside buildings), in metallic drums or in bulk bags. At some plants, the different raw materials are stored in dedicated rooms where the room temperature is maintained at a constant 20 °C. Storage areas have no drainage points in the floor. Only some raw materials (e.g. sulphuric acid, nitric acid) are stored in aboveground storage tanks equipped with secondary containment.

#### 6.4.2.3 Raw material solution

Solid raw materials are usually dissolved in water to prepare aqueous solutions containing the anionic and cationic components of the SIC explosive product.

The proportion of water used to prepare the solutions is considered confidential information by the SIC explosive producers.

Adjustment of the solution's pH is of significant importance for product quality.

#### 6.4.2.4 Reaction

The material solutions are brought to the reactor (stirred tank of <100 litres capacity) by means of pipes and valves where they are agitated and heated up to approximately 50 °C. Dextrine is added to obtain a proper product grain shape and size (dextrine is a natural product that acts as a crystalline modifier, but is used only in the production of lead azide, not in the production of other SIC explosives).

The reaction (i.e. precipitation) is carried out by adding two or more water solutions to the vessel. The temperature and the pH both have a significant influence on the quality properties of the explosive produced (e.g. particle size and shape). Formation of crystal needles overly sensitive to shocks is to be avoided particularly in the production of lead azide. The reaction takes place at atmospheric pressure and leads to the formation of a precipitated lead salt.

Residence time in the reactor is about one hour. The temperature is controlled by external heating and/or cooling through jackets. Agitation of the solution is stopped to allow explosive crystals (of about 70 μ in size) to settle at the bottom of the reactor. The mother liquor (containing explosive impurities and unreacted lead nitrate) is removed from the reactor and led to waste water treatment. Temperature and residence time in the reactor are important factors to control in order to avoid the formation of large crystals that are sensitive to handle even below water.

### 6.4.2.5 Purification of SIC explosives

At reaction temperatures, the SIC explosives are always insoluble in the reacting media. Therefore, purification is usually carried out by solid-liquid separation and washing with water and a small quantity of organic solvents (mainly ethyl alcohol) is used to minimise organic impurities. The SIC explosive powder is loaded up on antistatic trays (containing less than 5 kg of products) and manually transported to the drying area. Waste water (containing explosive impurities and unreacted lead nitrate) which comes from the purification step is led to waste water treatment.

### 6.4.2.6 Drying of SIC explosives

For safety reasons, the drying area is located at some distance from the reactor's room (prevention of the 'domino effect'). The drying area consists of built-in closets where the trays are deposited. Hot air (65 – 70 °C) circulates in the closets through the trays and dries the moist crystals (steam is used as the source of energy to heat the circulating air). Residence time in the drying area is about 72 hours. The warm air is circulated at a low flowrate in order to avoid particulate emissions (from the SIC explosive powder) into the drying room.

SIC explosives (mainly trinitroresorcinate) are often not dried and directly mixed with other products in a 'wet' phase.

### 6.4.2.7 Handling and storage of SIC explosives

Finished products are stored in storage buildings equipped with extensive electrical protection (e.g. ground lines) and safety systems. Storage buildings are located at safe distances from any other building to prevent a 'domino effect' in the event of an accidental detonation. Security systems are also in operation in every handling and storage area, particularly to prevent intrusion. No special environmental issues are related to the storage of inorganic explosive products, as long as a maximum temperature of 20 – 25 °C is maintained during storage.

## 6.4.3 Consumption and emission levels

Figure 6.22 presents the consumption of raw materials, auxiliary chemicals, energy and water for the production of SIC explosives. Emissions to water from the production of SIC explosives are shown in Figure 6.23.

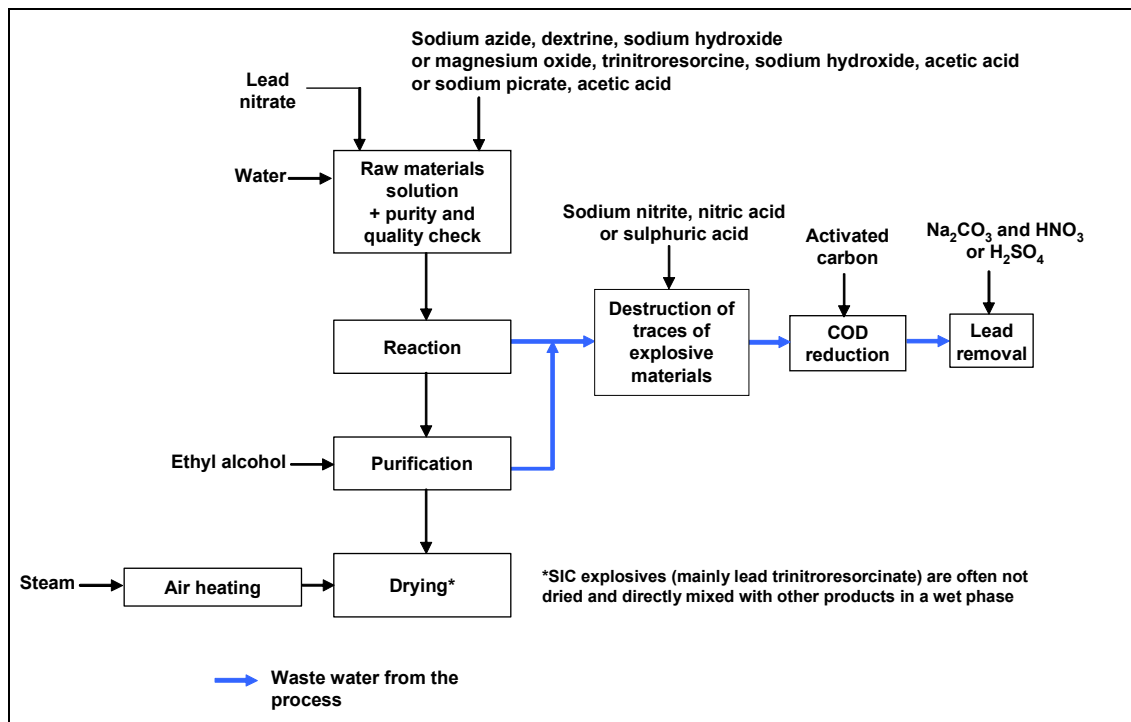

Figure 6.22: Consumption of raw materials, auxiliary chemicals, energy and water for the production of SIC explosives

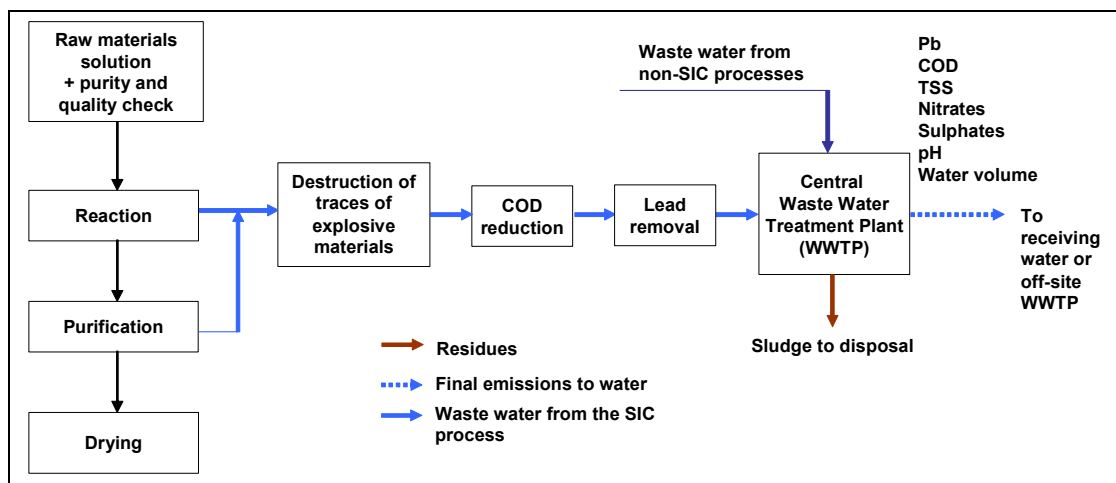

Figure 6.23: Emissions to water from the production of SIC explosives

The purity and quality check of the raw materials is of paramount importance to avoid the production of defective products that will have to be reprocessed (increase of energy use) or managed as waste (increase of waste volume) and consequently will result in increasing the overall environmental impact of production.

### 6.4.3.1 Raw materials and auxiliary chemicals consumption

The production of **lead azide (LA)** necessitates raw and auxiliary materials as indicated in Table 6.21.

Substance	Use	Production step	Quantity (in kg/kg of LA produced)
Lead nitrate	Raw material	Reaction	1.14
Sodium azide	Raw material	Reaction	0.45
Dextrine	Crystalline modifier	Mixing with sodium azide	Confidential data
Sodium hydroxide	pH adjustment	Reaction	Confidential data
Ethyl alcohol	Washing of LA	Purification	Confidential data
Sodium nitrite	Chemical destruction (i.e. oxidation reaction) of explosive impurities in waste water before lead removal treatment	Waste water treatment	Confidential data (twice the equimolecular quantity of nitric acid related to sodium nitrite)
Nitric acid	Chemical destruction (i.e. oxidation reaction) of explosive impurities in waste water before lead removal treatment	Waste water treatment	Confidential data
Ferric chloride	Verify the completeness of the above oxidation reaction	Waste water treatment	Trace quantities for chemical qualitative analysis of explosive impurities in water
Sodium carbonate	Precipitation of lead carbonate as part of the lead removal treatment	Waste water treatment	{no information provided}
Activated carbon	Adsorption of coloured organic impurities in waste water	Waste water treatment	{no information provided}

**Table 6.21: Raw and auxiliary materials used in the production of lead azide (LA)**

The production of **lead trinitroresorcinate (LTNR)** necessitates raw and auxiliary materials as indicated in Table 6.22.



Substance	Use	Production step	Quantity (in kg/kg of LTNR produced)
Lead nitrate	Raw material	Reaction	0.74
Magnesium oxide (or magnesium hydroxide)	Raw material	Reaction	0.09
Trinitroresorcine	Raw material	Reaction	0.54
Sodium hydroxide	pH adjustment	Reaction	Confidential data
Acetic acid	pH adjustment	Reaction	Confidential data
Ethyl alcohol	Washing of LTNR	Purification	Confidential data
Sodium polysulphides	Chemical destruction of explosive impurities	Waste water treatment	0.27
Hydrochloric Acid	Chemical destruction of explosive impurities	Waste water treatment	0.41
Sodium hydroxide	pH adjustment	Waste water treatment	0.14
Sulphuric acid	Chemical destruction of explosive impurities in waste water <b>and</b> precipitation of lead sulphate as part of the lead removal treatment	Waste water treatment	Confidential data
Activated carbon	Adsorption of coloured organic impurities in waste water	Waste water treatment	Approximately 0.27

**Table 6.22: Raw and auxiliary materials used in the production of lead trinitroresorcinate (LTNR)**

The production of **lead picrate (LP)** necessitates raw and auxiliary materials as indicated in Table 6.23.

Substance	Use	Production step	Quantity (in kg/kg of LP produced)
Lead nitrate	Raw material	Reaction	{no information provided}
Sodium picrate	Raw material	Reaction	{no information provided}
Acetic acid	pH adjustment	Reaction	{no information provided}
Water	Washing of LP	Purification	{no information provided}
Sulphuric acid	Chemical destruction of explosive impurities in waste water	Waste water treatment	Confidential data
Activated carbon	Adsorption of coloured organic impurities in waste water	Waste water treatment	Confidential data

**Table 6.23: Raw and auxiliary materials used in the production of lead picrate (LP)**

#### 6.4.3.2 Energy consumption

Electricity is the main type of energy used for the production of SIC explosives (e.g. lighting, powering of motors in pumps and stirrers).

Steam is used for heating the air needed to dry the explosive crystals after the purification step. It may also be used for heating the reactors. Steam is provided by natural gas boilers or other means.

In 2004, the total consumption levels at a Spanish installation were around 103000 kWh (approximately 6600 kWh per tonne of SIC explosives produced). Consumption at a Czech installation is estimated at approximately 12000 kWh per tonne of SIC explosives produced. This is due to the extra energy needed to operate an evaporator used after the reaction step in order to re-use water in solutions of raw materials (90 % of the water is recuperated).

### 6.4.3.3 Water consumption

Water is used in the production of SIC explosives for:

- putting raw materials into solutions (see Section 6.4.2.3)
- washing of the explosive crystals in the purification step (see Section 6.4.2.5)
- cleaning equipment
- cooling equipment.

The proportion of water used in solutions of raw materials is confidential information of the SIC explosive producers. The water used to clean production equipment is collected and sent to waste water treatment to remove its lead content. Significant quantities of water are used to maintain production building floors wet in order to avoid sparks from static electricity.

The estimated consumption of fresh water at a Spanish installation represents approximately 500 m<sup>3</sup>/t of SIC explosives produced [23, Castresana, 2004]. Consumption of fresh water at a Czech plant is about 10 % of that of the Spanish installation (i.e. 50 m<sup>3</sup>/t of SIC explosives) due to the re-use of water permitted by the operation of an evaporator after the reaction step.

For installations with large production capacities and/or where the ratio between energy cost/water cost justifies it, water consumption can be lowered down to 50 m<sup>3</sup>/t of SIC explosives produced by performing appropriate recycling dispositions (see Section 6.4.4.2).

### 6.4.3.4 Air emissions

There are no significant air emissions from the production of SIC explosives.

Only very minor fugitive emissions of ethyl alcohol arise from the purification and drying steps. In addition, some low volume emissions arise from the chemical destruction of the dissolved explosive residues contained in the waste water. Fugitive air emissions are neither collected nor treated due to their very low volume and negligible impact on the environment.

It can also be noted that CO<sub>2</sub> may be emitted to the air during the treatment of waste water arising from the production of SIC explosives (carbon dioxide is produced in the reaction between acidic waste water and sodium carbonate solution).

### 6.4.3.5 Water emissions

Waste water from the production of SIC explosives (originating from the reaction and purification steps) mainly contain lead soluble salts (i.e. lead nitrate raw material) and organic coloured materials (i.e. traces of trinitroresorcine raw material, partially soluble in water).

Waste water is generally treated in several steps; pretreatment steps are carried out within the SIC installation, followed by treatment in a central WWTP (see Figure 6.23).

The first operation in the pretreatment steps consists of destroying the traces of explosives materials (i.e. LA, LTNR or LP) contained in the waste water by using nitric acid and sodium nitrite (in case of production of LA) or sulphuric acid (in case of the production of LTNR).

Activated carbon is used for the adsorption of organic impurities (e.g. trinitroresorcine) responsible for the yellow/green colour of the waste water. After such a treatment, COD is reduced to <600 mg O<sub>2</sub>/l.

Lead contained in waste water is precipitated by adding sulphate and/or carbonate anions to obtain solid lead sulphate and/or lead carbonate (this treatment is carried out together with the destruction of traces of explosives material in the production of LTNR). The efficiency of the lead removal pretreatment used at a Spanish installation is shown in Table 6.24.

Type of production	Total lead concentration in waste water before pretreatment	Total lead concentration in waste water after pretreatment and before discharge to a central on-site WWTP
Production of lead azide	1500 mg/l	5 mg/l
Production of lead trinitroresorcinate	30000 mg/l	15 mg/l

**Table 6.24: Efficiency of the lead removal pretreatment in the production of lead azide and lead trinitroresorcinate at a Spanish installation**

In the production of lead azide and lead trinitroresorcinate at a Spanish installation, water effluent (after removal of traces of explosive materials, lead removal and activated carbon treatment) is collected and treated in a central on-site Waste Water Treatment Plant (WWTP) together with other industrial waste waters coming from industrial activities not covered in this document. This central WWTP has no biological treatment. Sludge from this central WWTP is sent to an off-site contractor authorised to deal with such waste. The company has the intention to send, in the near future, the effluent coming out of the central on-site WWTP to a municipal waste water treatment plant that includes aerobic and anaerobic steps, and carries out nitrification/denitrification.

Neutralisation is also used for pH adjustment of the final effluent before discharging it into the river or the municipal sewerage system.

Because of the rather constant value of the parameters in the water effluent, monitoring of the water effluent (before and after the central on-site WWTP) is carried out every two weeks at the Spanish plant.

The typical concentration of pollutants in waste waters at the output of the central WWTP at the Spanish plant is given in Table 6.25.

Pollutants	Concentration (mg/l)
COD	200
Nitrates	1900 as $\text{NO}_3^-$
pH	5.5 – 9.5
Soluble lead	0.05 – 0.5
Sulphates	900 as $\text{SO}_4^{2-}$
TSS	150

**Table 6.25: Typical concentration of pollutants in waste waters at the output of the central WWTP**

Annual water emission levels and concentration values of pollutants in discharged water from different installations in Europe are given in Table 6.26 and Table 6.27.

Reference plant	TSS	COD	Nitrates (as NO <sub>3</sub> <sup>-</sup> )	Sulphates (as SO <sub>4</sub> <sup>2-</sup> )	Pb	Volume of waste water treated	Remarks
	kg/t of end-product				g/t	m <sup>3</sup> /yr	
Plant A <sup>1</sup>	75	100	950	450	250	12500	Based on 25 t/yr of end-product
Plant B	3.2	310	1400		0.2		
Plant C							
Plant D							
Plant E							
Plant F							

<sup>1</sup> Environmental data estimated from internal chemical analysis

Table 6.26: Annual water emission levels in the production of SIC explosives

Reference plant	TSS	COD	Nitrates (as NO <sub>3</sub> <sup>-</sup> )	Sulphates (as SO <sub>4</sub> <sup>2-</sup> )	Pb	Volume of waste water treated	Remarks
	mg/l				mg/l	m <sup>3</sup> /h	
Plant A <sup>1</sup>	150	200	1900	900	0.5	3.5	Volume based on 2 shifts per day
Plant B	11	1000	100		0.7		
Plant C			55				
Plant D							
Plant E							
Plant F							

<sup>1</sup> Environmental data estimated from internal chemical analysis

Table 6.27: Concentration values of pollutants in water emissions in the production of SIC explosives

#### 6.4.3.6 Solid wastes

In the **lead azide** production process, waste arises from waste water treatment sludge (containing lead carbonate – PbCO<sub>3</sub>) which is collected, put in metal drums and disposed of by an external contractor.

In the **lead trinitroresorcinate** production process, waste arises from waste water treatment sludge (containing lead sulphate – PbSO<sub>4</sub>) which is collected and disposed of by an external contractor.

Another type of waste is made of solid materials contaminated with traces of explosives.

Table 6.28 shows the quantity of solid wastes generated at a Spanish installation in 2003, which is considered typical.

Solid waste type	Quantity generated in 2003
Solid waste containing traces of explosives (e.g. coming from the hand washing of production equipment)	63 kg/t of explosives
Sludge containing PbCO <sub>3</sub>	350 kg/t of lead azide
Sludge containing PbSO <sub>4</sub>	210 kg/t of lead TNR
Spent activated carbon	270 kg/t of lead TNR

Table 6.28: Typical quantity of solid wastes generated at a Spanish installation

### 6.4.3.7 Odour and noise emissions

The main sources of noise at installations producing SIC explosives are motors, pumps, and fans. Odour is not an issue at installations producing SIC explosives.

### 6.4.4 Techniques to consider in the determination of BAT

For many years, nearly every explosive production installation in Europe has been carrying out extensive and detailed hazard studies and risk assessments.

Risk assessments and loss prevention strategies strongly affect any suggestion for changes in processes and/or equipment. For instance, the selection of new raw materials or new formulations must be carried out carefully and with special emphasis in maintaining the process safety at the highest technical level possible. During explosives manufacturing, even minor accidents can lead to a massive explosion.

Therefore, safety aspects are strong arguments for the determination of BAT in the production of explosives.

Taking into account the above-mentioned considerations, the techniques to consider in the determination of BAT for the production of SIC explosives are detailed below.

#### 6.4.4.1 Removal of lead from waste waters by precipitation with sulphuric acid or sodium carbonate (pretreatment technique)

##### Description

Lead nitrate is used in water solutions as a raw material for the production of SIC explosives. Because the entire lead nitrate is not consumed in the reaction, some lead nitrate is carried over into the waste water after separation of the (insoluble) SIC explosive crystals and needs to be removed.

Lead removal is usually carried out by precipitation in the form of two possible inorganic salts:

- lead sulphate –  $\text{PbSO}_4$
- lead carbonate –  $\text{PbCO}_3$ .

These two substances are moderately soluble salts and are easily separated by gravity from the waste water. They are disposed of by a waste contractor. Lead recovery is possible from these salts in lead metallurgical industries.

The simple addition of sulphuric acid or sodium carbonate to the mother liquors yields the precipitation reaction by adequately adjusting the pH of the reaction media.

This technique is not used in isolation, but as a pretreatment technique.

##### Achieved environmental benefits

- reduction of the lead concentration in the released waste water
- possibility of lead recovery in metallurgical furnaces.

**Cross-media effects**

- sulphuric acid (H<sub>2</sub>SO<sub>4</sub>) consumption
- sodium carbonate (Na<sub>2</sub>CO<sub>3</sub>) consumption
- the precipitants have to be disposed of as sludge.

**Operational data**

The efficiency of the lead removal pretreatment system at a Spanish installation is shown in Table 6.29.

Type of production	Total lead concentration in waste water before pretreatment	Total lead concentration in waste water after pretreatment and before discharge to a central on-site WWTP
Production of lead azide	1500 mg/l	5 mg/l
Production of lead trinitroresorcinate	30000 mg/l	15 mg/l

**Table 6.29: Efficiency of the lead removal pretreatment system at a Spanish installation**

The resulting lead concentration after pretreatment is limited by a number of factors, such as pH, the production process as well as the solubility of PbCO<sub>3</sub> (when sodium carbonate is the precipitation agent used) or by the solubility of PbSO<sub>4</sub> (when sulphuric acid is the precipitation agent used).

**Applicability**

- generally applicable.

**Economics**

Both sulphuric acid and sodium carbonate are chemicals that are cheap and available worldwide.

**Driving force for implementation**

- reducing emissions of heavy metals to water.

**Example plants**

- UEB plant in Galdácano, Spain.

**Reference literature**

23rd International Annual Conference of ICT 1992, 'Waste management of energetic materials and polymers', J-L. Chen, S-J. Jing, C-H Lin, 'Elimination of detrimental constituents from plant effluents resulting from the manufacture of basic lead styphnate', 30 June – 3 July 1992, Karlsruhe, Germany.

#### 6.4.4.2 Removal of traces of explosive materials containing lead from waste waters using a neutralisation station

##### Description

A neutralisation station can be used to treat the waste waters loaded with traces of explosive materials containing lead coming from the reaction and purification steps of the SIC explosives production process. The neutralisation station is composed of the following main elements:

- neutralisation tanks
- evaporator/concentrator (for the treatment of water-based liquids)
- chamber filter press.

The removal of traces of explosive materials containing lead from the waste waters is carried out in two steps.

Traces of explosive materials containing lead in the waste waters are decomposed in the neutralisation tanks by chemical methods to non-explosive substances (salts). In the case of lead trinitroresorcinate, the decomposition is according to the following reaction:

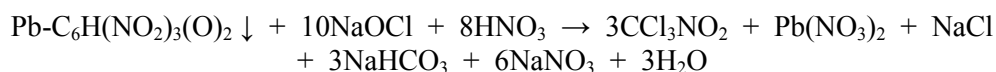

Off-gases from the decomposition process (containing hydrogen azide, chlorine and chloropicrin) are treated on a carbon filter. The carbon filter is regenerated off-site by a specialised company. Sludge (containing most of the lead) from the neutralisation tanks is pumped to the chamber filter press.

The liquid part which has substances containing traces of lead is pumped to the evaporator/concentrator and this uses the combined effect of vacuum and heat pump technology to make water-based liquids boil at a low temperature (20 – 30 °C). At a plant in the Czech Republic, the solid residues from the evaporator are managed by an external contractor and sent to a secure disposal site. The concentrate liquid residue is mixed to the other (non-SIC) waste waters of the plant, the overall water effluent being treated in a (off-site) municipal WWTP.

The following are possible outputs from the neutralisation station:

- hydrogen azide (HN<sub>3</sub>) gas (absorbed on a carbon filter)
- chlorine (absorbed on a carbon filter)
- chloropicrin (absorbed on a carbon filter)
- clean water (returned back to production)
- concentrated liquid residues (to disposal).

##### Achieved environmental benefits

- reduction of the lead concentration in the released waste water
- reduction in water consumption through re-use of the cleansed water in the production process.

##### Cross-media effects

- emissions to air (hydrogen azide, chlorine and chloropicrin)
- generation of concentrated liquid residues to be disposed of
- generation of solid residues to be disposed of
- consumption of electricity (installed power: 35 kW, consumption: 0.177 kWh/l) and pressurised air
- consumption of auxiliary chemicals (H<sub>2</sub>SO<sub>4</sub>, NaNO<sub>2</sub>, NaOCl, NaOH).

## Operational data

The operational data provided in this section comes from the example plant mentioned below.

A very low level of maintenance is required. The treatment capacity is 3000 l/day. Concentrated liquid residues coming out of the neutralisation station amounts to 120 l/day. The noise level in the neutralisation station is about 74 dB.

The technical specifications of the evaporator used in the example plant as well as a daily mass balance are given respectively in Table 6.30 and Table 6.31.

Parameter	Value	Remarks
Power input	31 kW	
Production of distillate – yield	175 l/h	Theoretical
Production of distillate – yield	155 l/h	Real
Production of liquid concentrate	15 l/h	
Evaporation ratio (clean water distillate:concentrate)	9:1	
Specific consumption	0.177 kWh/l	

**Table 6.30: Technical specifications of the evaporator**

Parameter	Value
Waste water input to the evaporator/concentrator	4080 l
Water output from the evaporator/concentrator that is returned to the process	3720 l
Concentrate liquid residue	360 l
Solid residue from filter press	4 kg

**Table 6.31: Example of a daily mass balance**

## Applicability

This technique is applicable to treat waste waters coming from the production of lead azide, lead trinitroresorcinate and lead picrate.

The use of an evaporator/concentrator is viable, from an economic point of view, if the cost of water supply is high and the cost of electricity supply is low: if the cost of 177 kWh is more than the cost of 1 m<sup>3</sup> of water, the technique is not economically viable.

Applicability also depends on the size of the installation: for small production units, the cost of building an evaporator/concentrator might be too high whatever the respective cost of water supply and electricity.

## Economics

- about EUR 250000 for the purchase and operation of the equipment, without the building.

## Example plants

- AUSTIN plant, Czech Republic.



### 6.4.4.3 COD reduction through treatment with activated carbon

#### Description

A significant COD reduction can be achieved by segregation of waste water streams with high COD loads and a subsequent treatment with activated carbon before release to the central waste water treatment plant (WWTP). The use of activated carbon also permits the removal of colouring substances from the waste water effluent being treated.

#### Achieved environmental benefits

- effective reduction of the COD released to receiving waters
- removal of colouring substances in waste water.

#### Cross-media effects

- consumption of activated carbon.

#### Operational data

After treatment with activated carbon, the COD of the water effluent is reduced from >1500 mg to <600 mg O<sub>2</sub>/l.

#### Applicability

- generally applicable.

#### Economics

Activated carbon is a product that is rather cheap and available worldwide. The cost of carbon regeneration or disposal (by a waste contractor) is significant in the case of a high COD load.

#### Driving force for implementation

- reduction of COD levels and removal of colouring substances in water effluents.

#### Example plants

- UEB plant in Galdácano, Spain.

#### Reference literature

See Section 3.3.4.2.9 on adsorption techniques in the CWW BREF [21, European IPPC Bureau, 2003].

### 6.4.4.4 Destruction of explosive impurities from waste water

#### Description

In the production of lead azide, minor quantities of nitric acid and sodium nitrite (NaNO<sub>2</sub>, solid) are used for the chemical destruction of explosive impurities in the waste water before lead removal treatment.

The reaction of this chemical destruction of explosives is as follows:



#### Achieved environmental benefits

- removal of (toxic and) explosive chemical substances (lead azide) from the waste water.

#### Cross-media effects

- consumption of sodium nitrite and nitric acid
- emission of oxides of nitrogen.

#### Operational data

Quantities of nitric acid and sodium nitrite are added in excess to guarantee the total destruction of traces of lead azide. A ferric chloride test is carried out to be sure that no explosive substances are present in the water effluent after the treatment.

#### Applicability

- generally applicable at plants producing lead azide.

#### Economics

- relatively low cost of chemicals and equipment (e.g. stirred tank reactor).

#### Driving force for implementation

- avoids detonation accidents that can cause environmental effects.

#### Example plants

- UEB plant, Galdacano, Spain
- Austin Detonator, Vsetin, Czech Republic.

#### Reference literature

Tadeusz Urbanski, Chemistry and Technology of Explosives, vol. 3, Pergamon Press, Oxford, UK (1985).

Fedoroff, B.T., Encyclopedia of Explosives and Related Items, vol.1, Picatinny Arsenal, Dover, NJ, USA (1960).

#### 6.4.4.5 Ground protection

##### Description

Because SIC explosive installations represent a contamination potential to the ground, surface water and groundwater, they are designed, built, operated and maintained in such a way that no spills occur. They are sealed, stable and sufficiently resistant against possible mechanical, thermal or chemical stress. Leakages are quickly and reliably recognised.

Leaking substances are safely retained and treated/disposed of. This is realised by applying an impervious and stable retention area according to the amount of substance that could be spilled before other measures take effect. Additionally, double walled equipment with leak detection can be used.

The ESB BREF [8, European IPPC Bureau, 2003] describes techniques used to prevent emissions to the environment from the storage and handling of solids, liquids and liquefied gases.

##### Achieved environmental benefits

- prevention of contamination to the ground, surface water and groundwater.

##### Cross-media effects

- no issues.

##### Operational data

- a retention volume of at least 110 % of the capacity of the largest tank or drum in the contributing area and at least 25 % of the total capacity of the stored/handled volume is often used as a benchmark
- the integrity and tightness of all structure boundaries and their resistance to penetration by water or other substances are tested and demonstrated
- the loading and unloading of materials are carried out only in designated areas protected against leakage run-off. While awaiting disposal, all materials are collected and stored in designated areas protected against leakage run-off
- all pump sumps or other treatment plant chambers from which spillages might occur are equipped with alarms activated by high levels of liquid or pump sumps are regularly inspected by personnel
- a programme for the testing and inspection of tanks and pipelines is established and carried out
- inspections are carried out for leaks on all flanges and valves on pipes used to transport materials other than water. A log of these inspections is maintained
- a catchment system is provided to collect any leaks from flanges and valves on pipes used to transport materials other than water, except when the construction of flanges or valves is technically tight
- an adequate supply of containment booms and suitable absorbent material is provided
- all bunds are tested at least once every three to five years.

##### Applicability

- generally applicable.

### **Driving force for implementation**

- prevention of contamination to the ground, surface water and groundwater.

### **Example plants**

- UEB plant in Galdácano, Spain.

### **Reference literature**

OFC BREF [18, European IPPC Bureau, 2004].

ESB BREF [8, European IPPC Bureau, 2003].

### 6.4.5 Best Available Techniques

Noting the introduction of BAT given in Chapter 5 and remembering that generic BAT for the SIC sector are also defined in Chapter 5, this section presents specific BAT conclusions generally applicable to the production of speciality inorganic explosives. Therefore, BAT for the production of SIC explosives is the combination of the generic elements presented in Chapter 5 and the specific elements indicated in this section.

Risk assessment and loss prevention strategies strongly affect any suggestion for change in the production process and/or equipment. For instance, the selection of new raw materials or new formulations must be carried out carefully and with special emphasis in maintaining process safety at the highest level. At explosives manufacturing installations, even minor accidents can lead to a mass explosion which can affect almost the entire installation virtually instantaneously. Therefore, safety aspects may be strong arguments for determining BAT in the production of SIC explosives [15, Castresana, 2004].

#### Safety measures

The BAT presented below apply without prejudice of the provisions of the Seveso II Directive (Directive 96/82/EC) in particular.

In order to avoid the 'domino effect' in the case of an explosion, BAT is to:

6.4.1 separate production and storage buildings on the production site. (See Sections 6.4.2.6 and 6.4.2.7)

BAT is to:

6.4.2 reduce the risk of explosions of electric origin by storing SIC explosives in buildings equipped with electrical protection (ground lines) and safety systems. (See Section 6.4.2.7)

#### Prevention of soil pollution

#### Air emissions

To avoid particulate emissions to the air when drying SIC explosives, BAT is to:

6.4.3 circulate warm air into the drying room at a flowrate that prevents SIC explosive particulates being carried in the airflow (See Section 6.2.4.6).

#### Waste water treatments

BAT is to:

6.4.4 collect all used process waters (i.e. mother liquor, wash-water, clean up water) and send them to treatment.

6.4.5 before lead removal treatment (see BAT 6.4.7), pretreat the waste water under acid conditions (e.g. using sulphuric acid or nitric acid) in order to chemically decompose (i.e. oxidation reaction) traces of explosive substances contained in the waste water (see Section 6.4.4.4).

6.4.6 reduce organic impurities in the waste water by using activated carbon (see Section 6.4.4.3).

- 6.4.7 minimise the amount of lead in the waste water by precipitation with sulphate and/or carbonate anions (see Section 6.4.4.1).
- 6.4.8 recycle waste water back into the production process where the production scale and/or the ratio between energy cost/water cost justifies this by using an evaporator/concentrator (see Section 6.4.4.2) and achieving a consumption of process water of  $\leq 50 \text{ m}^3/\text{t}$  of SIC explosives (see Section 6.4.3.3).

Once the waste water has been pretreated as indicated in BAT 6.4.5 through to BAT 6.4.8, BAT is to:

- 6.4.9 send the waste water to a central WWTP for treatment. If the central WWTP does not have denitrification treatment (and nitrification if necessary), BAT is to subsequently treat the waste water in a biological WWTP (on-site or off-site, e.g. municipal WWTP) with denitrification (and nitrification if necessary).

### Handling of solid residues

BAT is to:

- 6.4.10 recover lead contained in solid residues (sludge from waste water treatment) in lead metallurgical industries (see Section 6.4.4.1) or appropriately dispose of solid residues containing lead (see Section 6.4.3.6).

## 6.5 Cyanides

[16, CEFIC Cyanide Sector and Working Group, 2004] [1, Ullmann, 2001]

Within the scope of this document, 'cyanides' signify the speciality inorganic chemical compounds containing the cyanide ion ( $\text{CN}^-$ ). Hydrogen cyanide (HCN), also called hydrocyanic acid, is not included.

This section only focuses on water soluble sodium cyanide (NaCN) and potassium cyanide (KCN). The other inorganic cyanide salts are not addressed due to their reported low production volume.

### 6.5.1 General information

Pure NaCN and KCN are white to off-white crystalline solids. They are odourless when dry and they exhibit a bitter almond odour when exposed to humidity. These cyanides are often called 'alkali cyanides' because they render an alkaline pH to water when dissolved in it. This is due to hydrolytic equilibrium ( $\text{CN}^- + \text{H}_2\text{O} \leftrightarrow \text{HCN} + \text{OH}^-$ ), where free alkaline is formed from these salts made from a weak acid and a strong base.

These solid cyanides can be readily dissolved in water to prepare cyanide solutions containing approximately 30 % NaCN and approximately 40 % KCN at 20 °C.

When these cyanides come into contact with acids (weak or strong), or when they are dissolved in water, HCN can be formed and released. This applies to the dissolved, as well as to the solid, cyanides. The liberation of HCN is pH driven. The curve in Figure 6.24 describes the basic behaviour of a cyanide solution.

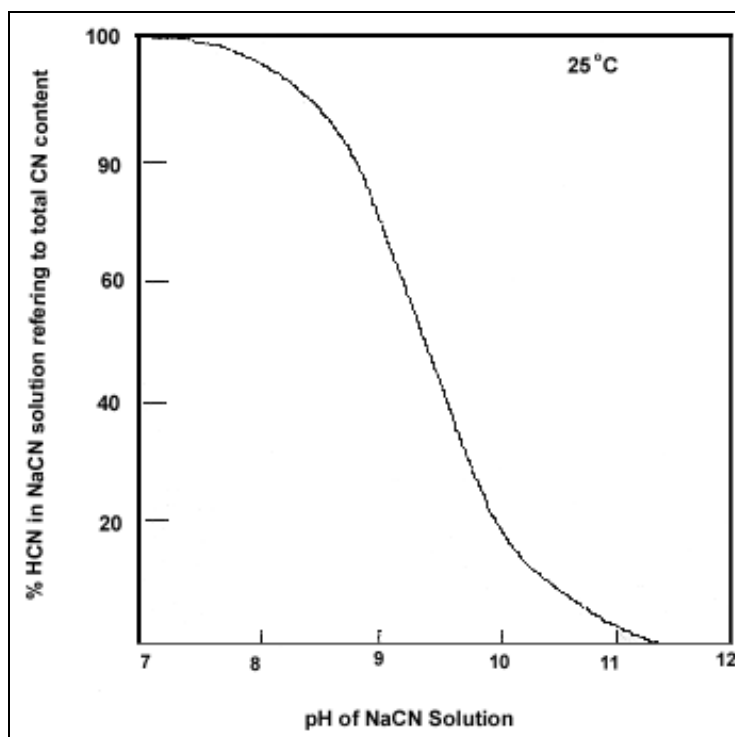

Figure 6.24: Basic behaviour of a cyanide solution

When solid cyanides and colourless cyanide solutions come into contact with acids, they can change from their white colour into anything from light yellow to dark brown. The intensity of the colour change depends on a variety of parameters. This behaviour is due to a polymerisation reaction of HCN. Because such behaviour affects the quality of the products (cyanide solutions – especially during production – as well as solid cyanides), cyanides need to be stabilised by the addition of excess alkali (the alkali used is normally NaOH or KOH).

In this sense, alkali cyanides are sensitive to any contact with humid air which contains carbon dioxide (which is a weak acid in water solution). Only if additional stabilisation with an alkali takes place, is the acid neutralised to form carbonate and the cyanide is protected from decomposition by the acid.

Sodium cyanide is commercially available in briquettes, in a granular or powder form, or as an aqueous solution. Potassium cyanide is available as briquettes, or in a granular or powder form.

### 6.5.1.1 Uses and markets

The major part of **worldwide** cyanide production is used for the application of sodium cyanide in gold mining to extract gold from its ores (approximately 70 % of the total sodium cyanide produced is used for this purpose). Gold, in its elementary form, is very stable and does not react easily with a number of the even very aggressive chemicals. Usually, only in the presence of a strong oxidant together with a complexing agent can gold be reacted and be made water soluble (soluble gold salts). In gold mining, cyanides are used as complexing agents.

The other two largest applications of cyanides **worldwide** are the chemical synthesis of organic and inorganic compounds (e.g. to produce pharmaceuticals, food additives, feed additives, pigments, complexing agents) and the electroplating of metal surfaces (e.g. zinc, gold, silver). In the latter application, potassium cyanide is preferred, particularly for the deposition of gold and silver.

**In Europe**, the largest application of cyanides is in the chemical synthesis industry. The second largest application in Europe is for the electroplating of metal surfaces together with metal hardening. The use of cyanides in the mining industry only comes in third position.

### 6.5.1.2 Quality of the cyanide products/specifications

The quality of cyanides depends on the heavy metal impurities they contain which originate from the NaOH or KOH raw materials. Among cyanide users, the electroplating industry has the highest requirements and, therefore, sets quality standards in terms of heavy metal impurities in the cyanides. The mining industry could basically accept cyanides with a higher content of heavy metal impurities but is actually not supplied with a different specification than the one for the electroplating industry. All end users apply the same high quality specifications for cyanides.



Apart from heavy metals, cyanides may contain impurities originating from their production process. The main impurities that can be generated in the cyanide production process are cyanate ( $\text{OCN}^-$ ), formate ( $\text{HCOO}^-$ ) and carbonate ( $\text{CO}_3^{2-}$ ). However, generally speaking, none of these are critical in any way for cyanide applications (very often these impurities are formed in the application processes anyway). Carbonate originates mainly from the contact of excess alkali with carbon dioxide in the air. Hydrolysis of cyanide at high temperatures (e.g. in the drying step of the production process, see Section 6.5.2.6) leads to the formation of formate and ammonia ( $\text{NH}_3$ ). Cyanate can be formed due to oxidation processes. Ammonia can also be seen as a possible impurity especially in solutions after a longer storage time at elevated temperatures. If slow hydrolysis in solid (wet) material takes place, the ammonia formed can be released to the gas phase around the material but is normally not built up/concentrated in the material itself. Due to these reactions that lead to the formation of HCN and/or  $\text{NH}_3$ , commercial cyanide solutions can (mainly after a long storage time under non-ideal storage conditions) have a smell of HCN and/or  $\text{NH}_3$ . Absolutely dry cyanides do not normally smell of any of these species as the presence of water is necessary for any of the decomposition reactions that lead to the release of HCN and/or  $\text{NH}_3$ .

The typical liquid cyanide product specifications are presented in Table 6.32.

Type of solution	Specifications
Sodium cyanide solution	NaCN 30 % +/- 0.5 % NaOH 0.5 % +/- 0.25 %
Potassium cyanide solution	KCN 40 % +/- 0.5 % KOH 0.5 % +/- 0.25 %

**Table 6.32: Typical liquid cyanide product specifications**

The typical solid cyanide product specification is minimum 98 % pure (2 % water maximum).

### 6.5.1.3 Toxicity

A major feature of cyanides is their high toxicity for most life forms, by all routes of exposure (i.e. ingestion, inhalation, dermal absorption).

Cyanides form a number of metal cyanide complexes, most of them having toxicity similar to the free cyanide itself.

### 6.5.1.4 Cyanides production in Europe and worldwide

In Europe and worldwide, the most important alkali cyanides, in terms of production volumes, are **sodium cyanide** (NaCN) and **potassium cyanide** (KCN).

Current worldwide sodium cyanide production is about 500000 tonnes (dry basis) per year. The total amount of potassium cyanide produced worldwide is significantly lower compared to the production of sodium cyanide.

In Europe, NaCN and KCN are produced at less than a dozen sites, each producing between 8000 and 50000 tonnes (dry basis) of these products per year. A significant amount of these chemicals is produced for captive use, meaning that the cyanides are used as intermediates in the production of other substances at the site. However, the greatest amount of NaCN and KCN is produced to be sold within Europe and for export outside Europe.

The same production facilities can be used for the manufacture of NaCN and KCN.

The sites where **sodium cyanide** and **potassium cyanide** are produced in Europe are listed in Table 6.33.

<b>Location (city, country)</b>	<b>Product(s)</b>
Wesseling, Germany	NaCN liquid NaCN solid KCN solid
Geleen, the Netherlands	NaCN liquid
Billingham, United Kingdom	NaCN liquid
Ludwigshafen, Germany	NaCN liquid
Antwerp, Belgium	NaCN liquid
Kolin, Czech Republic	NaCN solid
Pitesti, Rumania	NaCN liquid
Seal Sands, United Kingdom*	NaCN liquid
Saint-Avold, France*	NaCN liquid
Roussillon, France*	NaCN liquid
* captive use	

**Table 6.33: Sites where sodium cyanide and potassium cyanide are produced in Europe**

The worldwide production capacity of cyanides is currently about 650000 tonnes for a market of about 500000 tonnes. European production capacity is currently around 140000 tonnes for a market of about 80000 tonnes.

#### 6.5.1.5 Features of the European cyanide industry

In Europe, large enterprises (over 250 employees) and medium sized enterprises (between 50 and 249 employees) manufacture cyanides. The workforce employed to run the cyanide production facilities within these companies, is generally below 60. Production is carried out in medium sized facilities using a continuous mode of operation. Production is carried out in installations that are part of a larger chemical complex where the HCN raw material is manufactured (due to the fact that HCN poses serious transportation issues).

#### 6.5.1.6 Economics

The differences in market values between NaCN and KCN are often the reflection of the market value differences of their raw materials NaOH and KOH. As KOH is significantly higher in value than NaOH, KCN is more expensive than NaCN. According to the Chemical Market Reporter of 8 December 2003, selling prices in Europe for NaCN/KCN are also subject to fluctuations in the world market. According to this report, prices were mainly less than USD 1650 per tonne for NaCN (100 % purity), and less than USD 3000 per tonne for KCN (100 % purity).

During recent years, production of cyanides has consolidated to a significant extent in Europe resulting in the closure of a number of production sites.

## 6.5.2 Applied processes and techniques

### 6.5.2.1 Main types of production processes

Two main kinds of processes are available worldwide for the production of cyanides:

- the melting process
- the water solution process.

**In the melting process**, a cyanide source is not needed as a raw material; cyanides are produced from non-cyanide components (reaction of sodium metal with charcoal and ammonia). The result is solid cyanides with different kinds of impurities, e.g. carbon black from using carbon as the raw material.

When cyanides are produced **in the water solution process** (also called the neutralisation process), the cyanide source is provided by HCN raw material. As the cyanide needs to be applied with a counter cation which makes the cyanide stable and cost effective to produce, NaOH (for the production of NaCN) or KOH (for the production of KCN) is used as the neutralisation agent. The production of HCN is, therefore, an important intermediate step for the production of alkali cyanides. However, for the reason indicated at the beginning of this section, the production of HCN is not addressed in this document.

Nowadays, the water solution process is the method most largely used worldwide. Only where electricity costs are sufficiently low can melting processes be competitive. **This section focuses on the water solution process only as the melting process is not used industrially in Europe.**

As an example, Figure 6.25 shows the main production steps for the production of cyanides using a water solution process. Liquid cyanides are produced as a result of a neutralisation/crystallisation step followed by product filtration. Solid cyanides (powder, granular or briquettes) are produced as a result of subsequent process steps: drying, compaction, granulation, separation from fine dust and eventually sieving or briquetting.

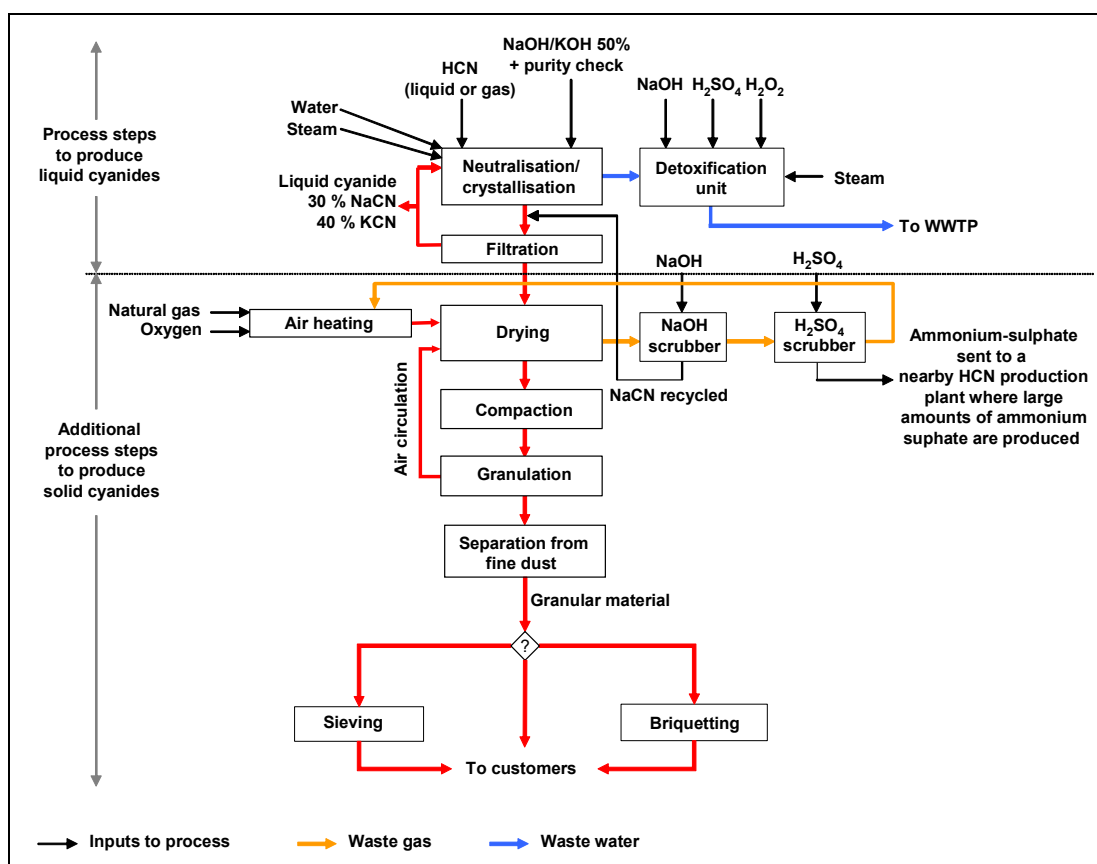
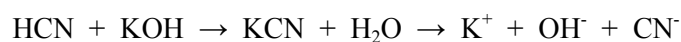
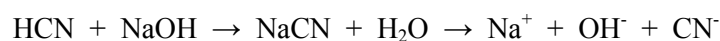

Figure 6.25: Main steps for the production of sodium or potassium cyanide using a water solution process

In Europe, cyanides are produced in liquid as well as in solid forms. Cyanide solutions are generally concentrated to get the best efficiency for transport. Cyanide solutions are used where the application industry site is close enough to the cyanide production site so as to keep the transportation of the solution competitive against the costs of solid production (i.e. the evaporation of excess water and the formulation of solid material).

### 6.5.2.2 Process chemistry

The formation of the cyanides is a simple chemical neutralisation reaction between a weak acid (HCN) and a strong base (OH<sup>-</sup>). The neutralisation reaction is given for both the production of NaCN and KCN:



An alkaline salt is formed and this is because of the alkaline pH in the water after dissolution/hydrolysis of the cyanide salt and the subsequent formation/liberation of OH<sup>-</sup> from the water.

### 6.5.2.3 Raw materials and auxiliary chemicals storage and handling

#### Raw materials

The raw materials used for the production of cyanides are HCN, NaOH or KOH and water.

As HCN is a product that poses serious transportation issues, cyanide production plants are located close to HCN production plants or close to plants producing HCN as a by-product (e.g. acrylonitrile production). The HCN supplied is always kept in motion and at a cool temperature of about 5 °C to prevent polymerisation.

NaOH and KOH are supplied to the cyanide production facility from a tank farm via a pipeline. These raw materials are either produced on the chemical complex where the installation is located or are delivered from external suppliers to the tank farm by ship, rail or road. NaOH and KOH raw materials are stored in steel or stainless steel tanks with a capacity of between 50 and 1000 m<sup>3</sup>. All tanks are equipped with the necessary safety devices (e.g. overfill protection, secondary containment, double bottom).

Fresh water may be used as the raw material in a proportion that depends on the cyanide concentration requested by customers for the liquid cyanide product.

#### Auxiliary chemicals

For the production of NaCN/KCN, no auxiliary chemicals are needed.

For the detoxification of cyanide residues, hydrogen peroxide (H<sub>2</sub>O<sub>2</sub>) or chlorine-based chemicals, and sulphuric acid, are used. These chemicals are stored in suitable tanks and delivered to the cyanide plant by pipeline.

### 6.5.2.4 Neutralisation/crystallisation

The neutralisation reaction leads to an energy release of 460 kJ/mol. This energy is used in the subsequent vaporisation of water to form NaOH or KOH crystals (crystallisation).

The neutralisation reaction necessitates the raw materials HCN and NaOH or KOH to be in stoichiometric proportions. The use of special mixing devices and the addition of 0.2 – 3 % excess NaOH or KOH prevents the polymerisation of HCN. The efficiency of the neutralisation reaction has a higher than 98 % yield based on HCN. That means that all of the HCN used is transferred into the end-product NaCN or KCN and only minimal losses of HCN occur.

Simultaneously to the neutralisation reaction or in a second step, water is vaporised under reduced pressure and the alkali metal cyanide is precipitated below 100 °C (crystallisation). The shorter the residence time of the cyanide in solution, the cleaner the product and the lower the content of hydrolysis products and iron impurities will be [1, Ullmann, 2001]. The evaporated water is condensed before entering the cyanide detoxification unit. A side reaction in the crystalliser (i.e. the hydrolysis of cyanide) results in the formation of NH<sub>3</sub> that needs to be abated.

The neutralisation reaction results in the formation of a dissolved NaCN (or KCN) salt (46 % NaCN solution when using 50 % NaOH and 99 % pure HCN raw materials; 47 % KCN solution when using 50 % KOH and 99 % pure HCN raw materials). Further along, the raw solution can either be concentrated or diluted with water, depending on the final product required. Usually, the aim is to form a concentrated cyanide solution containing approximately 30 % sodium cyanide or 40 % potassium cyanide.

### 6.5.2.5 Filtration

The crystals of NaCN or KCN are separated from the solution by filtration (drum filters or filter presses are used as the filtering device). Depending on the filtering device used, between 2 and 15 % of water remains in the solid cyanide. The solution is then returned to the crystalliser and the crystals are fed into the drying step.

### 6.5.2.6 Drying

The moist NaCN crystals (which still contain about 12 % water) are dried (at about 300 °C) with hot, CO<sub>2</sub> free air which circulates in a closed loop within the process (see Figure 6.25). The drying and filtration steps operate in a slight vacuum so that small amounts of additional air might be sucked in. The excess air contaminated with HCN and NH<sub>3</sub> is sent to an air cleaning system. The contaminated air is treated in a washing system which uses NaOH for abating HCN and sulphuric acid (H<sub>2</sub>SO<sub>4</sub>) for abating NH<sub>3</sub>. The excess air can also be incinerated in the air heaters if it is contaminated with organic compounds, such as benzene. After drying, crystals are separated in cyclones. At this stage, cyanide salts contain up to 0.5 % moisture.

### 6.5.2.7 Compaction

The crystals which have a low bulk density are pressed in rotating rolls to increase their bulk density. The compacted crystals are then granulated.

### 6.5.2.8 Granulation

The cyanide crystals are granulated in a rotative knife granulator.

### 6.5.2.9 Separation from fine dust/sieving/briquetting

As the granulation step might create fine dust, dust is separated before producing the granules. A low content of fine dust in the granules has advantages in terms of safety and processing of the product at the customer's site. The granules are then either filled into packages or are processed to briquettes or powder. The fines are separated from the granules in a sieve. The briquettes are formed in a pressing machine with rotating rolls.

### 6.5.2.10 Packaging and storing of cyanides

Solid cyanides are generally filled into plated steel drums (usually containing between 50 and 100 kg of products) or in one tonne bags (usually made of polypropylene and equipped with an inner polyethylene liner for further protection and to make the packaging both air and water tight) which are transported in plywood boxes. The lid of the drum is fixed with a locking ring and hermetically sealed.

Drums are generally used for customers from smaller industries (e.g. the electroplating industry) and plywood boxes for customers from larger industries (especially for the mining industry).

Returnable packaging allowing multiple uses is an important alternative to the application of single use packaging. Both single use packaging and returnable packaging are used worldwide for transporting solid cyanides.

An alternative for transporting cyanides is the so called Solid to Liquid System (SLS). Solid cyanides are filled into a unit containing approximately 20 tonnes of material. This unit is transported to the customer's site and the solid cyanides are dissolved at the user's facility and pumped to a storage facility. The transportation unit can be refilled with solid cyanide material frequently.

The packaging chosen for solid cyanides depends on technical, economic and environmental considerations.

Liquid cyanides are always transported in returnable packaging (metal drums or railcars). Liquid cyanide is only economically feasible within a limited radius of the production plant. The concentration of the solution can be adjusted to ensure that, even in winter, no precipitation occurs. Liquid cyanide is easier to handle and is the preferred form when large quantities of cyanides are required and aqueous solutions can be used.

All packaging must meet the official requirements for the transportation of toxic substances (UN approval). All packaging is labelled according to transport regulations.

Metal drums and plywood boxes loaded with products are stored in a dedicated covered area (where only cyanides are stored) equipped with extensive security and fire safety systems (e.g. the storage area is fenced, equipped with locked doors and roofed to keep rainfall out; the use of water is prohibited for extinguishing a fire in the storage area).

#### 6.5.2.11 Handling and storage of cyanides

[1, Ullmann, 2001]

The stability of solid cyanides under dry conditions and isolated from air is very high, even at fairly high temperatures. Only when exposed to moist air, can solid and liquid cyanide react with carbon dioxide to release HCN:

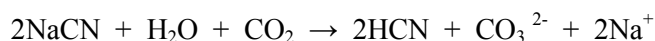

Cyanides are stored in a dry place and protected against corrosion. Storage rooms are well ventilated. Storage of cyanides is separated from strong oxidants (e.g. nitrates, chlorates, nitric acid, peroxides), acids, food and feedstuffs, carbon dioxide, water or products containing water.

The cyanide storage area is clearly marked and unauthorised personnel are never allowed access to rooms in which cyanides are stored or processed. Therefore, a cyanide area is separated from other areas, e.g. by fences or walls. In the case of an emergency, powder fire extinguishers, safety showers, eye washes, and antidotes are available in the immediate vicinity.

Stainless steel is used as the construction material for equipment that comes into contact with cyanide solutions. However, concentrated cyanide solutions are stored in steel or stainless steel containers which are protected against leakage by a collecting basin constructed of alkali-resistant concrete.

Before being packaged (into bulk containers or railcars) and sent to customers, cyanide solutions are stored at the production site in steel or stainless steel tanks that have a capacity of between 50 and 1000 m<sup>3</sup>. All tanks are equipped with the necessary safety devices (e.g. overflow protection, secondary containment, double bottom).

Work with cyanides requires the greatest possible caution and strictest adherence to all safety measures. It is not permitted to work alone, to eat, drink, smoke, use snuff, or chew gum (when handling cyanide). Also, it is prohibited to store any food, beverages, or smoking material in the cyanide area. Production of cyanides is carried out in strictly enclosed systems to prevent any contact of cyanide with the skin or eyes, as well as the respiration of cyanide dust or hydrogen cyanide gas. If a danger of cyanide contamination exists, rubber gloves, rubber boots, a rubber apron, and safety goggles or protection for the face and head are readily available. Safety showers and eye washes are located within the immediate vicinity of each cyanide area.

### 6.5.3 Consumption and emission levels

The consumption of raw materials, auxiliary chemicals, energy and water for the production of cyanides is depicted in Figure 6.25. Emissions to air from the production of cyanides are shown in Figure 6.26, and emissions to water are shown in Figure 6.27.

Emissions from the production of cyanides mainly consist of HCN and NH<sub>3</sub> in the gas effluents and of cyanides in the liquid effluents.

#### 6.5.3.1 Raw materials and auxiliary chemicals consumption

The neutralisation/crystallisation reaction (see Section 6.5.2.4) needs the raw materials HCN and NaOH or KOH in stoichiometric proportions, together with a small excess of NaOH or KOH (0.2 – 3 %). The reaction yield (based on HCN) is higher than 98 %.

The quantity of raw materials needed to produce one tonne of NaCN and one tonne of KCN respectively is shown in Table 6.34.

	NaOH	KOH	HCN
Product	tonnes		
NaCN	0.82	<del>          </del>	0.55
KCN	<del>          </del>	0.87	0.42

**Table 6.34: Quantity of raw materials needed to produce one tonne of NaCN and one tonne of KCN respectively**

HCN is currently produced by the direct reaction of alkanes with ammonia, and indirectly as a by-product of the manufacture of acrylonitrile (25 % of the hydrogen cyanide in the US and 20 % in western Europe is obtained as a by-product in the manufacture of acrylonitrile by the oxidation of propane and propylene in the presence of ammonia [1, Ullmann, 2001]).

When HCN comes from an acrylonitrile plant, impurities in the HCN raw material (99 % pure HCN) mainly include benzene (about 70 ppm). There are no other significant impurities in the HCN raw material.

NaOH and KOH with a very low content of heavy metals are used in the production of cyanides in order to limit the release of heavy metals into the environment as a result of the production process and in order to meet the requirements of the electroplating industry (see Section 6.5.1.2).

For the oxidative destruction (in the detoxification unit) of cyanide residues contained in water effluents, hydrogen peroxide (H<sub>2</sub>O<sub>2</sub>) or chlorine-based chemicals are used. NaOH and sulphuric acid (H<sub>2</sub>SO<sub>4</sub>) are used in the air cleaning system to abate HCN and NH<sub>3</sub> after the drying step. At an installation producing 20000 tonnes of NaCN (dry basis) per year, typically 100 tonnes of detoxification material (H<sub>2</sub>O<sub>2</sub> or chlorine-based chemicals), less than 50 tonnes of H<sub>2</sub>SO<sub>4</sub> and less than 100 tonnes of NaOH are used.



### 6.5.3.2 Energy consumption

The energy costs for the production of cyanide are mainly based on electricity and steam. Electricity is used to power control systems, motors and pumps and to heat tanks and pipes used to transport NaOH. Natural gas is used to power air dryers. Steam is used in the crystallisation and in the waste water detoxification unit. Steam is produced by high pressure boilers.

The consumption of steam is between 1.3 – 1.5 tonne of steam/t 100 % NaCN/KCN. The consumption of electricity is between 0.1 – 0.15 MWh/t 100 % NaCN/KCN.

### 6.5.3.3 Water consumption

Water is used in the production of cyanides for:

- preparing the cyanide solution
- cleaning equipment
- cooling equipment.

For the production of the cyanide solution (only relevant for the neutralisation/crystallisation and filtration steps) water is needed as a raw material by dosing in the pipeline. Most of the water needed to produce a commercially viable cyanide solution comes from the caustic (NaOH or KOH) solution which is a major water source. Additional water needed is either fresh water or process water.

Water is also used for equipment cooling purposes (e.g. cooling towers).

In addition, water is used for cleaning process equipment (washing and rinsing water). After cleaning, the cyanide contaminated water is collected and re-used in the production process. Water with a low cyanide concentration is fed to the detoxification unit.

### 6.5.3.4 Air emissions

Air emissions for a well operated cyanide production plant, which produces NaCN and KCN as solid product and as solution, is given in Table 6.35.

Pollutant	Emissions to air <sup>1</sup>
	g/t 100 % NaCN or KCN
HCN	0.5 – 2
NH <sub>3</sub>	0.7 – 3
NO <sub>x</sub>	100 – 500
VOCs	0 – 0.01

<sup>1</sup> The values were developed from measurements of emissions in different cyanide production plants. The ranges give a best practice depending on the process and technology used and on site-specific conditions which vary from site to site (i.e. waste water treatment). For instance, one site reports a frequency of one emission analysis every three months

**Table 6.35: Emissions to air from a well operated cyanide production plant**

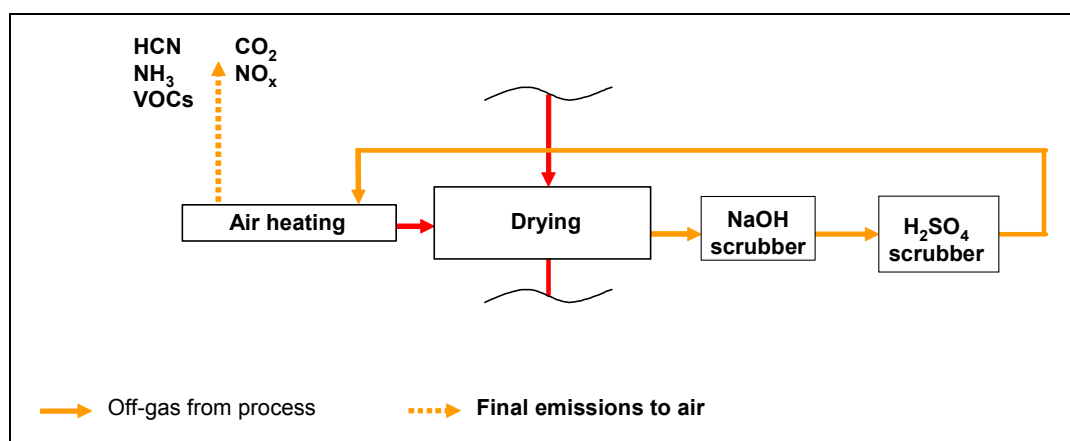

Figure 6.26: Emissions to air from the production of cyanides

### NH<sub>3</sub> and HCN emissions

NH<sub>3</sub> and HCN are contaminants present in the excess air coming from the drying step.

NH<sub>3</sub> is formed as a result of the hydrolysis of cyanides under high temperature. Cyanate (OCN<sup>-</sup>) is formed first and leads to the further formation of NH<sub>3</sub>.

HCN comes from the neutralisation/crystallisation step as an unreacted raw material.

NH<sub>3</sub> and HCN are abated in a washing system which uses NaOH for the abatement of HCN and sulphuric acid (H<sub>2</sub>SO<sub>4</sub>) for the abatement of NH<sub>3</sub>. The solution containing NaCN recuperated in the alkaline scrubber is recycled back into the production process. The solution containing ammonium sulphate recuperated in the acid scrubber is recycled, i.e. to a nearby HCN production plant where large amounts of ammonium sulphate are produced as forced by-products.

For health and safety reasons, monitoring devices are installed for the detection of NH<sub>3</sub> and HCN in the work areas.

### CO<sub>2</sub> and NO<sub>x</sub> emissions

CO<sub>2</sub> and NO<sub>x</sub> emissions arise from the combustion of natural gas used to power the air heaters that serve to dry the NaCN/KCN crystals prior to compaction. The combustion gases (CO<sub>2</sub> and NO<sub>x</sub>) from the heaters are emitted to the air.

All measures are taken to reach the lowest hourly emission rate of NO<sub>x</sub>. This includes:

- optimisation of the construction of the burner
- reduction of nitrogen components in the process gases
- separation of gas streams with high VOC concentration from gas streams with no VOC contamination
- reduction of flowrates.

### VOC emissions

VOC emissions originate from the incineration of air contaminated with organic compounds (such as benzene which may be an impurity contained in the HCN raw material – see Section 6.5.3.1) in the above-mentioned air heaters. VOCs are abated in the air heaters.

### 6.5.3.5 Water emissions

Waste water mainly originates from the neutralisation/crystallisation step. Waste water emissions mainly consist of free cyanide in the waste water streams.

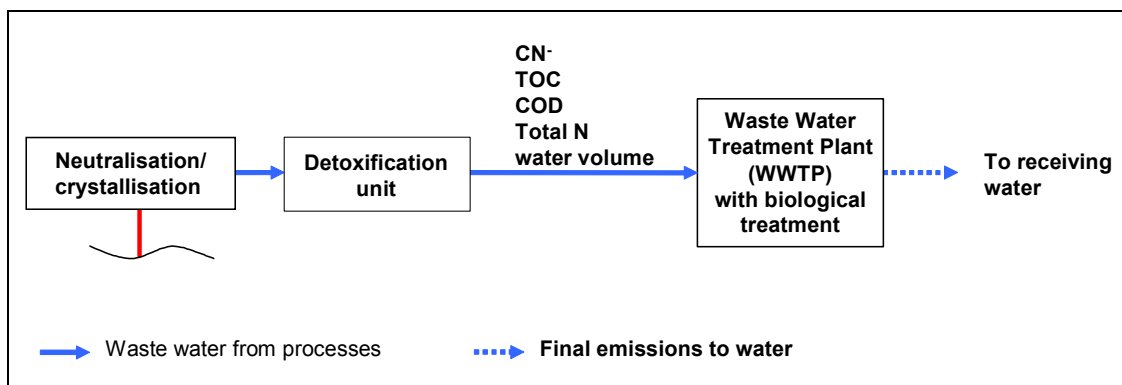

Figure 6.27: Emissions to water from the production of cyanides

Excess water from concentrating cyanide solutions is evaporated in the crystallisation step and either taken back to the process after condensing, or sent to the detoxification unit.

After detoxification (see Section 6.5.4.1), cyanide concentration in the treated water effluent which is sent to public waterways is far below 0.01 ppm of free cyanide.

While most of the water which is evaporated is subsequently condensed, a small amount of the vapours and non-condensable gases must be treated before being released to the air. This is accomplished by the use of wet scrubbers, or incineration, or a combination of both. Wet scrubber systems utilise liquid scrubbing solutions designed to contain or neutralise the non-condensable gases. Abatement efficiencies for these systems exceed 98 %. Incineration or thermal oxidation systems are also utilised for detoxification of the gases. Abatement efficiencies for these systems exceed 99 %.

Discharge levels to a waste water treatment plant (WWTP) from a typical cyanide production plant, which produces NaCN and KCN as a solid product and as a solution, are given in Table 6.36. These levels are after detoxification and before the biological waste water treatment plant.

Pollutant	Emissions to a WWTP
	g/t 100 % NaCN or KCN
NH <sub>4</sub> <sup>(+)</sup> -N	400 – 2000
COD	800 – 4000
CN <sup>-</sup>	0.4 – 6
TOC	300 – 1500

Table 6.36: Discharge levels to a WWTP from a typical cyanide production plant

### 6.5.3.6 Solid wastes

No solid wastes are generated from the chemical reaction (e.g. no solid cyanide waste). Off-specification solid cyanide products are recycled back into the production process, by dissolving in waters contaminated with cyanides and re-injecting in the neutralisation/crystallisation step.

On the other hand, contaminated insulations, used hand gloves and damaged packaging (originating from filling or storage operations) are solid wastes from the production process. All solid waste material is washed free of cyanide with water prior to disposal (metals are recycled in steel mill; the rest is disposed of or incinerated). The wash-water containing cyanides is sent to the detoxification unit for treatment.

### 6.5.3.7 Odour and noise emissions

The main source of noise at the cyanide plants are motors, pumps, and fans. Noise is monitored regularly so that it does not become a nuisance. Odour is not an issue at cyanide production facilities.

### 6.5.3.8 Monitoring

Air monitoring is carried out either by calculations or by measurements. Some installations report that the air emissions are monitored on a one to three year basis and that the efficiency of the air cleaning system is monitored on a daily basis.

The water emissions are monitored continuously (in some cases, online analysis for free cyanide and total cyanide) or on a regular (mostly daily) basis (analysis) depending on the pollutant.

## 6.5.4 Techniques to consider in the determination of BAT

### 6.5.4.1 Destruction of cyanides from waste gases and waste waters using hydrogen peroxide (H<sub>2</sub>O<sub>2</sub>) as the oxidising agent

#### Description

Cyanides (in the form of HCN gas) are removed from waste gases using a scrubber with NaOH solution (or KOH solution). The solution is circulated between a buffer vessel and the scrubber. The solution is sampled regularly and exchanged if the content of free OH<sup>-</sup> is too low for the absorption of HCN from the air stream. The spent solution loaded with cyanides is then reconditioned (reconditioning consists basically of mixing the spent solution in order to achieve a fairly constant/homogeneous CN<sup>-</sup> concentration) with other CN<sup>-</sup> rich waste water streams to substitute raw materials in the neutralisation/crystallisation step (see Figure 6.25). A CN<sup>-</sup> low waste water stream exits the reconditioning unit. The remaining cyanide is destroyed together with CN<sup>-</sup> low waste water streams using pH adjustment and oxidative destruction with hydrogen peroxide (H<sub>2</sub>O<sub>2</sub>). A schematic of this technique is shown in Figure 6.28.

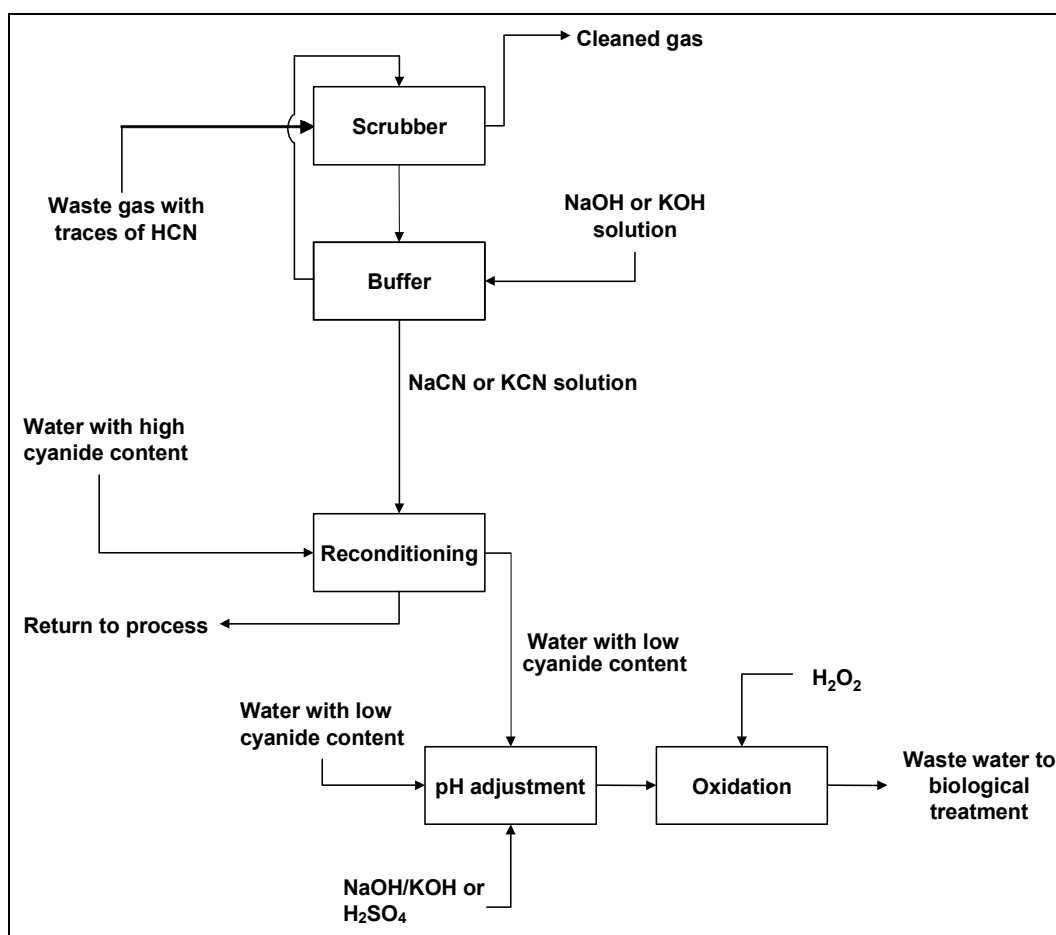
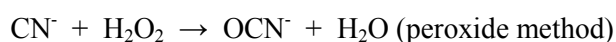
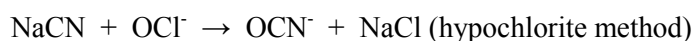

Figure 6.28: Destruction of cyanides from waste gases and waste waters

Using H<sub>2</sub>O<sub>2</sub> based technology (as opposed to hypochlorite, for example) does not generate salts and AOX by-products.



It is common to catalyse the reaction with a transition metal such as soluble copper, vanadium, tungsten or silver in concentrations of 5 to 50 mg/l. The oxidation requires 1.26 kg H<sub>2</sub>O<sub>2</sub> per kg of cyanide [41, H<sub>2</sub>O<sub>2</sub>.com, 2003].

#### Achieved environmental benefits

- removal of HCN/CN<sup>-</sup> from waste gases and waste waters
- re-use of waste water streams as raw materials
- no AOX in waste water
- no contaminated waste.

Achieved emission levels (for discharge to a biological WWTP) are given in Table 6.37.

	Concentration	Mass-flow	Reference
Waste gas	1 mg HCN/m <sup>3</sup>	3 g HCN/h	CyPlus, Germany
Waste water	1.1 mg CN <sup>-</sup> /l	2.3 g CN <sup>-</sup> /h	

Table 6.37: Achieved emission levels after oxidative destruction of cyanides

**Cross-media effects**

- consumption of energy
- consumption of hydrogen peroxide (H<sub>2</sub>O<sub>2</sub>)
- consumption of catalysts.

**Operational data**

		<b>Flow and concentration at the inlet of the treatment system</b>	<b>Reference</b>
<b>Treatment capacity</b>	Gas stream	3400 m <sup>3</sup> /h 50 mg HCN/m <sup>3</sup>	CyPlus, Germany
	Waste water with high CN <sup>-</sup> concentration	1 m <sup>3</sup> /h 5 % CN <sup>-</sup>	
	Waste water with low CN <sup>-</sup> concentration	15 m <sup>3</sup> /h 700 mg HCN/m <sup>3</sup>	
<b>Overall efficiency</b>	99.9 %		

**Table 6.38: Operational data for the destruction of cyanides**

A pH of 9 – 10 should be maintained to avoid the release of hydrogen cyanide (HCN) gas.

**Applicability**

- generally applicable.

**Economics**

- cost reduction for waste water treatment due to the absence of AOX load. The technique is in practice at some installations.

**Driving force for implementation**

- removal of toxic compounds from waste gases and waste waters.

**Example plants**

- CyPlus plant, Germany.

**Reference literature**

[41, H2O2.com, 2003]

### 6.5.4.2 Incineration of process air containing volatile organic compounds (VOCs)

#### Description

HCN raw material contains small amounts of volatile organic compounds (e.g. benzene) which can be found in several air streams of the production process. The air streams which contain VOCs are identified and separated from the others. The air streams containing VOCs are incinerated in an air heater which is run by natural gas. The energy from the incineration is used to heat up the air that is used to dry the cyanide crystals. A schematic of this technique is shown in Figure 6.29.

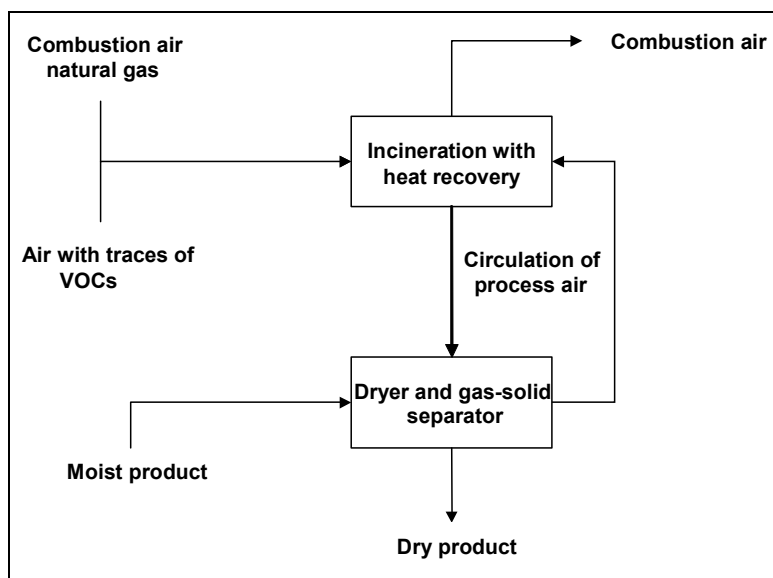

Figure 6.29: Incineration of process air containing volatile organic compounds (VOCs)

#### Achieved environmental benefits

- removal of VOCs (e.g. benzene) from waste gases
- saving of natural gas fuel by using benzene contained in the air streams as fuel
- the heat recovered from incineration is used to dry the cyanide crystals.

The achieved emission levels are given in Table 6.39.

	VOC concentration	Mass-flow	Reference
Waste gas	<0.6 mg/m <sup>3</sup>	0.4 g/h	CyPlus, Germany

Table 6.39: Achieved emission levels after incineration of VOCs

#### Cross-media effects

- none.

**Operational data**

		<b>Flow and concentration at the inlet of the treatment system</b>	<b>Reference</b>
<b>Treatment capacity</b>	Gas stream	2500 m <sup>3</sup> /h Variable benzene concentration	CyPlus, Germany
<b>Overall efficiency</b>		99.9 %	

Table 6.40: Operational data for the incineration of VOCs

**Applicability**

- generally applicable.

**Economics**

- reduction of energy costs
- comparably low investment costs.

**Driving force for implementation**

- removal of toxic compounds from waste gases.

**Example plants**

- CyPlus plant, Germany.



### 6.5.4.3 Cleaning-In-Place (CIP) system for equipment contaminated with cyanides

#### Description

During production, solid cyanide builds up in pipelines, machines and vessels and can ultimately provoke equipment malfunction or blockage. A Cleaning-In-Place (CIP) system allows easy cleaning and rinsing of equipment in a closed system. With such a system, workers are not exposed to harmful emissions. The rinsing water containing cyanide is collected in a closed piping system and stored in tanks. The rinsing water is then recycled back into the process to reduce the use of fresh water as a raw material. In addition, off-specification solid cyanide salts can be dissolved in the rinsing water collecting tanks and recycled back into the process in order to reduce the amount of hazardous waste produced. A schematic of this technique is shown in Figure 6.30.

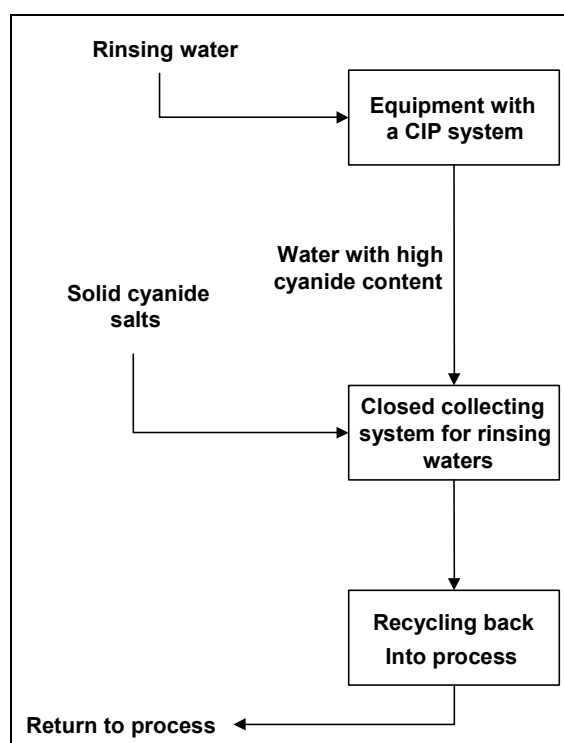

Figure 6.30: Cleaning-In-Place-system (CIP) for equipment contaminated with cyanides

#### Achieved environmental benefits

- no solid wastes containing cyanides
- recycling of waste water containing cyanides within the process
- reduction of raw material consumption (i.e. fresh water)
- protection of the workers
- reduction of emissions to the environment and to the working areas.

The achieved emission levels are given in Table 6.41.

	Concentration	Mass-flow	Reference
Solid waste		0 kg/yr	CyPlus, Germany

Table 6.41: Achieved emission levels associated with the cleaning of equipment contaminated with cyanides

**Cross-media effects**

- energy consumption.

**Operational data**

		<b>Flow and concentration at the inlet of the treatment system</b>	<b>Reference</b>
<b>Treatment capacity</b>	Rinsing water	15 m <sup>3</sup> /h Variable cyanide concentration	CyPlus, Germany
<b>Overall efficiency</b>	99 % <sup>1</sup>		
<sup>1</sup> The remaining 1 % of the cyanides either break up (hydrolysis) to by-products or end up in the cyanide detoxification unit			

**Table 6.42: Operational data for the cleaning of equipment contaminated with cyanides**

**Applicability**

- generally applicable.

**Economics**

- cost reduction for waste water treatment
- cost reduction for raw materials.

**Driving force for implementation**

- reduction of emissions to the environment and the working areas.

**Example plants**

- CyPlus, Germany.

#### 6.5.4.4 Removal of HCN and NH<sub>3</sub> from waste gases

##### Description

Hydrogen cyanide (HCN) and ammonia (NH<sub>3</sub>) are removed from waste gases using one alkaline scrubber with NaOH solution and one acidic scrubber with H<sub>2</sub>SO<sub>4</sub> solution. For each scrubber, the solution is circulated between a buffer vessel and the scrubber. The solution in each scrubber is sampled regularly and exchanged if the content of free OH<sup>-</sup> is too low for the absorption of HCN from the air stream or if the content of free H<sub>2</sub>SO<sub>4</sub> is too low for the absorption of ammonia. The spent solution from the alkaline scrubber is recycled back into the process to substitute raw materials in the neutralisation/crystallisation step (see Figure 6.25). The ammonium sulphate solution formed in the acidic scrubber can be recycled off-site (e.g. in plants producing fertilisers).

For safety purposes, the secondary containment of the acidic scrubber is strictly separated from the secondary containment of the alkali scrubber and the rest of the production building. This is to avoid, in the case of an accident, acids coming into contact with solutions containing cyanide, a situation which would lead to the emission of HCN into the environment.

A schematic of this technique is shown in Figure 6.31.

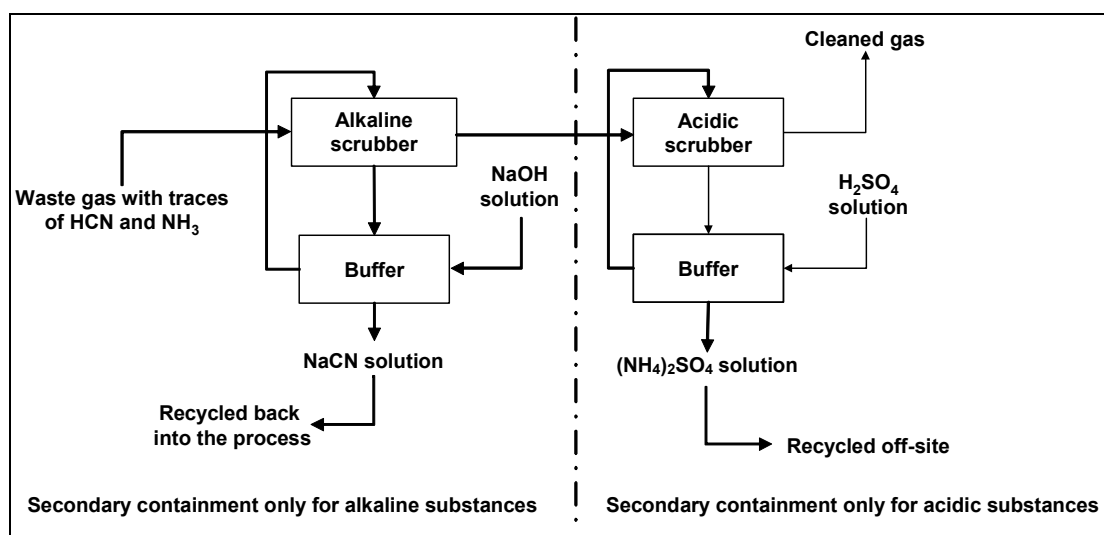

Figure 6.31: Removal of HCN and NH<sub>3</sub> from waste gases

##### Achieved environmental benefits

- removal of HCN and NH<sub>3</sub> from waste gases
- no waste water from the alkaline scrubber (re-use of the alkaline scrubber solution into the process to substitute raw materials)
- strict separation of acidic and alkaline containment reduces the potential for hazardous emissions in the case of an accident.

The achieved emission levels are shown in Table 6.43.

	Concentration	Mass-flow	Reference
HCN	1 mg/m <sup>3</sup>	3 g/h	CyPlus, Germany
NH <sub>3</sub>	1.2 mg/m <sup>3</sup>	3 g/h	

Table 6.43: Achieved emission levels for the removal of HCN and NH<sub>3</sub> from waste gases

**Cross-media effects**

- energy consumption.

**Operational data**

		<b>Flow and concentrations at the inlet of the treatment system</b>	<b>Reference</b>
<b>Treatment capacity</b>	Gas stream	3400 m <sup>3</sup> /h 50 mg/m <sup>3</sup> HCN 250 mg/m <sup>3</sup> NH <sub>3</sub>	CyPlus, Germany
<b>Overall efficiency</b>		99.2 %	

**Table 6.44: Operational data for the removal of HCN and NH<sub>3</sub> from waste gases**

**Applicability**

- generally applicable.

**Economics**

- low operation costs
- cost reduction for raw materials.

**Driving force for implementation**

- removal of toxic compounds from waste gases.

**Example plants**

- CyPlus, Germany.

#### 6.5.4.5 Returnable packaging for the transport of solid cyanides

##### Description

Besides single use packaging, returnable packaging is used for the transport of solid cyanides. In a filling line, the packaging (drums, boxes, IBCs) is filled with cyanides. After the customer empties the packaging, they are sealed and returned to the producer. A second option is that the part of the packaging that did not come into contact with the cyanides (i.e. plywood box) is disassembled by the customer and returned to the producer where it is checked and assembled again for re-use. The customers can be equipped with unloading devices to unload the content of the packaging in a closed system to avoid exposure to the workers.

##### Achieved environmental benefits

- reduction in the amount of contaminated packaging and waste.

##### Cross-media effects

- transport for the return of the packaging leads to additional fuel consumption.

##### Applicability

- generally applicable.

##### Economics

- reduction of packaging costs (depending on the contract, either the producer or the customer has to bear such costs)
- reduction of waste treatment costs.

##### Driving force for implementation

- reduction of contaminated waste.

##### Example plants

- CyPlus, Germany.

### 6.5.4.6 Use of a computerised control system to operate the plant

#### Description

The operation of a cyanide production plant requires numerous and frequent monitoring of operating parameters, and adjustments to the process conditions, particularly to ensure safety and environmental control. A computerised control system can help monitor hundreds of process parameters and automatically make the required adjustments to ensure a safe and environmentally sound operation. Using a computerised control system, automatic interlocks can be implemented to prevent the overfilling of tanks or to minimise the generation of waste water, for example.

#### Achieved environmental benefits

- reduction of emissions
- reduction of contaminated waste water
- health and safety of the workers
- reduction of raw material consumption.

#### Cross-media effects

- none.

#### Applicability

- generally applicable.

#### Economics

- slight reduction in production costs (e.g. energy, waste treatment).

#### Driving force for implementation

- more efficient control of process conditions
- reduction of emissions.

#### Example plants

- CyPlus, Germany.

#### 6.5.4.7 Double containment of cyanide plants

##### Description

Even if all measures are taken to prevent leaks, they can occur at cyanide production facilities (whether or not they originate from plant operations or because concrete or other traditional civil construction materials are subject to cracking) and can result in cyanide contaminated water being present on the ground floor of the production plant. Providing double containment for the ground floor and sumps reduces the potential for cyanide to be released to the soil or groundwater.

The containment is sized to hold the volume of the largest equipment in the building. Steel, stainless steel or special plastic materials, which are resistant to cyanides, can be used for containment.

##### Achieved environmental benefits

- reduction of soil contamination
- reduction of contaminated civil construction materials.

##### Cross-media effects

- none.

##### Applicability

- generally applicable.

##### Economics

- wide range of costs, from approximately EUR 100 to 5000/m<sup>2</sup>, mainly depending on the construction material used
- reduction of clean up and remedial costs.

##### Driving force for implementation

- improved assurance of no leakage of cyanide contaminated water to the soil.

##### Example plants

- CyPlus, Germany.

#### **6.5.4.8 Application of the International Cyanide Management Code (ICMC)**

##### **Description**

The International Cyanide Management Code (ICMC) for the manufacture, transport and use of cyanide in the production of gold is a voluntary industry code developed by a multi-stakeholder committee formed under the auspices of the United Nations Environment Programme (UNEP) and the International Council on Metals and the Environment (ICME). It is a voluntary programme of the gold mining industry, operating worldwide. The objective of the Code is to ensure very high standards for safety, environmental and quality aspects worldwide in the production, transport and use of cyanides in gold mining so that humans and the environment are protected.

The application of the Code at cyanide production plants entails activities such as auditing, certification, training of plant personnel.

##### **Achieved environmental benefits**

- reduction in the overall environmental impact of the production of cyanides.

##### **Cross-media effects**

- none.

##### **Applicability**

- generally applicable.

##### **Economics**

There are no savings to be made for applying the Code. Costs depend on the standards a cyanide producer already has in place – it therefore means less costs for producers who already have a sound environmental management system in place, and higher costs for those who do not.

Auditing can take a day, internal preparations for the audit can take several days to several weeks with the respective, e.g. personnel costs involved.

##### **Example plants**

- CyPlus, Germany.

##### **Reference literature**

<http://www.cyanidecode.org/>



#### 6.5.4.9 Storage measures for solid cyanides

##### Description

Solid cyanides are packaged in UN certified packages for the transport of dangerous goods and are stored at the cyanide plant in specially designed storage buildings. These storage buildings are fenced and locked to prohibit access to unauthorised personnel. Solid cyanides easily dissolve in water, therefore, storage buildings are constructed so that no rainfall and surface water can enter the building. Additionally, the use of water is prohibited for fire fighting purposes in the building (alkaline foams have to be used as fire extinguishing agent. The use of acidic foams is prohibited as HCN could be set free using this kind of foam).

##### Achieved environmental benefits

- reduction of soil and water contamination
- reduction of contaminated civil construction materials.

##### Cross-media effects

- none.

##### Applicability

- generally applicable, where solid cyanide salts are stored in packages.

##### Economics

- low construction costs.

##### Driving force for implementation

- enhancing safety and security standards.

#### 6.5.4.10 Using NaOH and KOH with a very low content of heavy metals

##### Description

NaOH and KOH are important raw materials for the production of NaCN and KCN. The overall quality of these materials is mainly influenced by their individual production processes. Based on these processes, heavy metal salts can be ingredients of these caustics in different ranges of concentration.

One of the major uses of cyanides is for electroplating purposes. In these applications different kinds of metal ions are precipitated mainly on metal surfaces. The electroplating process and the quality of end-products are strongly influenced by any kind of heavy metal salts in the working solution. Therefore, to achieve high quality end-products, the content of any undesired metal ion in any chemicals used needs to be as low as possible. For such electroplating processes, cyanides are produced with a very low content of heavy metal salts based on the use of NaOH and KOH with a very low content of heavy metals.

During cyanide production, heavy metals in the raw material NaOH and KOH may also lead to residues within the process. This effect may force additional measures to meet standards in occupational health care and may lead to the generation of additional hazardous waste.

### **Achieved environmental benefits**

- reduction of the amount of waste containing heavy metal ions
- exposure of personnel to heavy metals, especially mercury, lead and nickel is reduced
- technical optimisation of processes also leads to optimal environmental performance.

### **Cross-media effects**

- none.

### **Operational data**

- total heavy metals <5 ppm, Hg <0.1 ppm.

### **Applicability**

- generally applicable when cyanides are used in electroplating or in any process sensitive to heavy metal ions.

### **Economics**

- reduction of waste at electroplating facilities
- improved quality of end-products
- less efforts in monitoring and tracing the residues of heavy metals in the process
- potentially longer shelf life of end-products.

### **Driving force for implementation**

- process optimisation and end-product quality.

### **Example plants**

- CyPlus, Germany.

#### 6.5.4.11 High level of education and continuous training of personnel

##### Description

The complex process to produce cyanides, the use of modern technologies, the fact that highly toxic substances are produced and that emergency situations can occur put a lot of stress on the plant personnel, in particular the plant operators. To ensure that incidents are kept to a minimum, accidents are prevented and in order to reduce the risk of error in emergency situations, specific education and training programmes are implemented. Besides a sound basic education in chemical engineering and operations, plant personnel are continuously trained on the jobs. Their skills can regularly be evaluated and performance can be recorded after written or practical exams. Additionally, all operators are regularly trained on how to respond to emergency situations, on health and safety at work, and on product and transportation safety regulations.

##### Achieved environmental benefits

- reduction in the risks of incidents and accidents that could lead to emissions to the air, water and soil.

##### Cross-media effects

- none.

##### Applicability

- generally applicable.

##### Economics

Better education and continuous training of personnel leads to better decision-making when confronted by problems (including incidents and emergency situations) and finally to a reduction in production costs.

##### Driving force for implementation

- enhancing safety standards.

##### Example plants

- CyPlus, Germany.

### 6.5.5 Best Available Techniques

Noting the introduction of BAT given in Chapter 5 and remembering that generic BAT for the SIC sector are defined also in Chapter 5, this section presents specific BAT conclusions generally applicable to the production of cyanides. Therefore, BAT for the production of cyanides is the combination of the generic elements presented in Chapter 5 and the specific elements indicated in this section.

#### Raw materials selection

BAT is to:

- 6.5.1 minimise the amount of waste in the production process by using NaOH/KOH raw materials with a low content of heavy metals (see Section 6.5.4.10).

#### Air emissions

BAT is to:

- 6.5.2 achieve emission levels indicated in Table 6.45 (see Section 6.5.3.4).

Pollutant	Emissions to air <sup>1</sup>
	g/t 100 % NaCN or KCN
HCN	0.5 – 2
NH <sub>3</sub>	0.7 – 3
NO <sub>x</sub>	100 – 500
VOCs	0 – 0.01

<sup>1</sup> The values were developed from measurements of emissions in different cyanide production plants. The ranges give a best practice depending on the process and technology used and on site-specific conditions which vary from site to site (i.e. waste water treatment). For instance, one site reports a frequency of one emission analysis every three months

**Table 6.45: Emission levels to air associated with BAT for the production of cyanides**

In the production of solid cyanides, BAT is to:

- 6.5.3 minimise VOC emissions from the drying step by incinerating process air containing VOCs to achieve a removal efficiency of 99.9 % and re-using the energy from incineration to dry the cyanide crystals (see Section 6.5.4.2).

BAT is to:

- 6.5.4 minimise HCN and NH<sub>3</sub> emissions and achieve the emission levels shown in Table 6.45 by, e.g. using one alkaline scrubber with NaOH solution to abate HCN and one acidic scrubber with H<sub>2</sub>SO<sub>4</sub> solution to abate NH<sub>3</sub> (see Section 6.5.4.4).

BAT is to:

- 6.5.5 minimise NO<sub>x</sub> emissions by using a combination of the following techniques (see Section 6.5.3.4):
- optimising the construction of the burner
  - reducing nitrogen components in the process gases
  - separating gas streams with high VOC concentrations from gas streams with no VOC contamination
  - reducing flowrates.

Waste water management

BAT is to:

6.5.6 achieve the discharge levels indicated in Table 6.46 (see Section 6.5.3.5).

Pollutant	Emissions to a WWTP
	g/t 100 % NaCN or KCN
NH <sub>4</sub> <sup>(+)</sup> -N	400 – 2000
COD	800 – 4000
CN <sup>-</sup>	0.4 – 6
TOC	300 – 1500

**Table 6.46: Discharge levels to water at the inlet of the WWTP associated with BAT for the production of cyanides**

BAT is to:

6.5.7 minimise emission of cyanides to water by using techniques that oxidise cyanides (e.g. using peroxides – such as H<sub>2</sub>O<sub>2</sub>, see Section 6.5.4.1). Using hypochlorite is also BAT when the cyanide-effluent stream is free of organic material and when no free hypochlorite is left in the effluent after the oxidation reaction.

BAT is to:

6.5.8 minimise the consumption of raw material by reconditioning aqueous residues containing cyanides in order to substitute raw materials where technically possible (see Section 6.5.4.1).

Prevention of soil pollution

BAT is to:

6.5.9 use ground protection and strictly enclosed systems for the production of cyanides (see Section 6.5.2.11).

BAT is to:

6.5.10 use a dedicated covered area equipped with extensive security and fire safety systems to store cyanides (see Section 6.5.2.10).

BAT is to:

6.5.11 provide double containment for the ground floor and sumps in the production and storage areas (see Section 6.5.4.7). This involves both:

- a providing containment that is sized to hold the volume of the largest equipment in the building
- b. using steel, stainless steel or special plastic materials for containment, which are all resistant to cyanides.

Energy

BAT is to:

6.5.12 minimise the consumption of energy by recycling the heat released in the neutralisation reaction to vaporise water in the subsequent crystallisation step (see Section 6.5.2.4).

### Water consumption

BAT is to:

- 6.5.13 minimise the consumption of fresh water by a combination of the following:
- re-using filtrate from the filtration step into the crystalliser (see Section 6.5.2.5)
  - re-using cleaning water in the production process (see Section 6.5.4.3 and Section 6.5.3.6)
  - using a cleaning-in-place system (see Section 6.5.4.3).

### Product storage and packaging

BAT is to:

- 6.5.14 minimise the risk of accidents by storing cyanides in areas separated from the areas where strong oxidants (e.g. nitrates, chlorates, nitric acid, peroxides), water or products containing water are stored (see Section 6.5.2.11).

BAT is to:

- 6.5.15 minimise the amount of solid residues by, e.g. using returnable packaging for the transport of solid cyanides (see Section 6.5.4.5).

### Storage of solid cyanides

BAT is to:

- 6.5.16 store solid cyanides in covered, fenced and locked storage buildings. This includes both (see Section 6.5.4.9):
- making sure that no rainfall and surface water can enter the storage buildings
  - providing alkaline foams as the fire extinguishing agent in the storage buildings to be used in the event of a fire.

### Plant operation

BAT is to:

- 6.5.17 use a computerised control system to operate the plant (see Section 6.5.4.6).

BAT is to:

- 6.5.18 apply the principles of the International Cyanides Management Code (see Section 6.5.4.8). This includes both:
- applying high standards for safety, environmental and quality aspects in the production of cyanides
  - carrying out activities such as auditing, certification, training of plant personnel.

### Training of personnel

BAT is to:

- 6.5.19 have a high level of education and continuous training of personnel (see Section 6.5.4.11). This includes all of the following:
- having personnel with sound basic education in chemical engineering and operations
  - continuously training plant personnel on the jobs
  - regularly evaluating and recording performance of personnel
  - regularly training personnel on how to respond to emergency situations, health and safety at work, and on product and transportation safety regulations.

### 6.5.6 Emerging techniques

There are patented cyanide production processes which lead to the direct formation of solid cyanide in a fluidised-bed reactor using an alkali solution and HCN gas as the raw materials.

Other processes have been patented to dry cyanide crystals in a fluidised-bed reactor (Degussa patent).

However, these processes are currently not industrially applied and, therefore, cannot be considered for BAT yet, but as emerging techniques.

Any process leading directly to a transportable solid material which meets the quality and safety standards required by the customer would be ideal to be considered as BAT. This is the case for the patented processes to form solid cyanide granules – but this process is not used in large scale operations yet and needs to be considered as an upcoming technology.

Developments regarding the electrochemical elimination of cyanides in waste water are addressed in Section 7.4.





## 7 EMERGING TECHNIQUES

### 7.1 Decontamination of exhaust gases and waste water by chemically modified inorganic ion exchangers and active carbons

[38, Dr. Boenke, 2005]

#### General Information

This EU funded project will carry out comprehensive research and set up a semi-pilot plant for the production of adsorbents for the purification of industrial wastes and drinking water from heavy metal ions, radionuclides and organic toxic substances. New catalysts for the decontamination of exhaust gases from H<sub>2</sub>S, CO and NO will be studied. The project will combine the latest achievements in the field of development and application of new adsorbents (inorganic ionites) and catalysts (mainly based on synthetic and fruit shell and stone carbons as well as different composition oxides). Synthesis methods have already been developed and a technology for the production of inorganic ionites worked out, based on insoluble titanium and zirconium hydroxides and phosphates in the form of spherical granules which possess a high mechanical strength and a regulated surface chemistry. These materials were shown to have much better properties than most ion-exchange resins industrially produced in many countries. Hence this project aims to determine the optimum conditions for the decontamination of typical sewage waters from Cd<sup>2+</sup>, Cr<sup>3+</sup>, As<sup>3+</sup>, Zn<sup>2+</sup>, Al<sup>3+</sup>, Fe<sup>3+</sup> and Hg<sup>2+</sup> ions. The application of these ionites, combined with activated and oxidised carbons, is found to be very beneficial in the elaboration of cartridges for domestic use to purify drinking water from a great number of organic contaminants, radionuclides (which polluted the environment after the Chernobyl accident), and heavy metal ions, particularly microquantities of lead which are found in drinking water in some countries, e.g. UK and Germany. The project can be divided into the following research activities: preparation of adsorbent materials; characterisation of materials such as surface properties, morphology and mechanical properties; ion exchanges; catalytic behaviour; optimisation.

#### Achievements

The expected level of achievement of the two objectives is quite different. Concerning the activated carbonaceous materials (including adsorption and catalysis), the preliminary works carried out by the different participants and the existence of a semi-pilot plant of production will enable pre-industrialisation of the materials to be attained. The probability of success is higher for ion adsorptions than for the catalysis for the destruction of gaseous pollutants. The utilisation of inorganic ionites as adsorbents is more prospective. It is expected that the potential of the new materials will be verified and their efficiency compared with that of carbonaceous materials.

#### Reference literature

<http://www.cordis.lu/fp5/projects.htm>

<http://www.cordis.lu/fp6/projects.htm#search>

<http://www.cordis.lu/en/home.html>

## 7.2 Utilisation of industrial waste and especially petrochemical residues for power generation with low emissions

[38, Dr. Boenke, 2005]

### General Information

The concept is based on a confidential combustion system combined with a two step, dry flue-gas treatment system and an existing boiler. The combustor is composed of a high swirl, sub-stoichiometric combustion chamber, followed by an after combustion chamber, to which secondary air is added ensuring a residence time of 0.3 s and a temperature of 1200 °C. The particular geometry, together with the flow pattern lead to complete combustion, with low formation levels of NO<sub>x</sub>, CO and dioxins. The flue-gas is desulphurised by the injection of crushed limestone, together with recirculated flue-gas to reduce the temperature to a level of 1100 – 1150 °C. After heat recovery, lime powder and steam are added for HCl removal. Finally, the flue-gas is cleaned using bag filters.

### Achievements

The plant using this technique started full operation on September 1988. The burner capacity was varied between 120 – 450 kg of oil/h while for all tests the combustion air supplied was 125 m<sup>3</sup>/h. The operating temperature of the furnace was in the range of 1150 – 1250 °C and this was controlled by recycling flue-gases. The flue-gases purification system was modified considerably and it was concluded that hot gas desulphurisation was not needed while for HCl removal a combination of limestone and steam injection in the dechlorination reactor proved efficient and resolved all operational problems of solids and CaCl<sub>2</sub> accumulation. No problem was encountered with the bag filter.

Emission measurements for dust, CO, SO<sub>2</sub>, HCl and total carbon are performed continuously while emission measurements for inorganic halogen compounds (HF, phosgene), BTEX-aromatics, chlorinated hydrocarbons, PCB and PCDD are performed periodically. It was also noted that no significant amounts of phosgene BTEX-aromatics, chlorinated hydrocarbons and polychlorinated biphenyls are emitted by the installation and these were always well below the limits set by TA Luft. However, the emissions of dioxins from furnaces were always close to the limits specified by TA Luft and although the limits were rarely exceeded, the contractor plans to continue development work in this area. Nevertheless, it can be concluded that, from the emissions point of view, the furnace chamber system with swirl has proved to burn waste oils successfully. During the demonstration period which ended in December 1989, the demonstration plant fulfilled almost 80 % of the planned capacity of waste oils combustion and about 50 % of the targeted energy savings. The reduced capacity was due to technical optimisation at the flue-gas purification system while the reduced energy savings were due to the utilisation of an existing old type radiation boiler instead of a convection boiler.

### Reference literature

<http://www.cordis.lu/fp5/projects.htm>

<http://www.cordis.lu/fp6/projects.htm#search>

<http://www.cordis.lu/en/home.html>

### 7.3 Air filtration for the abatement of volatile chromium compounds in the tanning industry

[38, Dr. Boenke, 2005]

#### Objectives

The aim of this EU funded project is the identification of innovative technologies for the abatement of air pollutants (mainly chromium) from the air effluents of the tanning industry, to be applied in small sized plants mainly for the use of small and medium enterprises; a convenient option will connect a reasonable efficiency together with reduced investment and maintenance costs. A prototype of an innovative filtering system for chromium compounds will be developed, tested and certified with the direct involvement of end users partners. The system will have to comply with precise technical, and also economic, requirements which can ensure its actual and sustainable applicability (also for smaller tanning companies).

#### Reference literature

<http://www.cordis.lu/fp5/projects.htm>

<http://www.cordis.lu/fp6/projects.htm#search>

<http://www.cordis.lu/en/home.html>

### 7.4 Development and application of advanced ceramic electrodes for the electrochemical elimination of cyanides in waste water

[38, Dr. Boenke, 2005]

#### General Information

Baths containing cyanide compounds are found to be among the most used in galvanic industries. This noteworthy industrial presence of cyanides has been very questioned due to their high toxicity. Among the new methods of treatment of waste water contaminated with cyanides, the electrocatalytic oxidation of inorganic pollutants on high oxygen overvoltage ceramic electrodes should be noted. One example of this technique is the so-called Dimensionally Stable Anodes (DSA) that is used in the chlor-alkali industry. A European Union funded project has the aim of developing porous ceramic electrodes having stronger electrocatalytic activity as a result of their high area/volume relationship. The starting point will be the DSA technology, and different procedures of processing ceramics powders, such as SnO- and perovskite-like structures, which will be applied.

As the electrochemical elimination of cyanides in waste water is an energy intensive technique, there are questions as to whether it has economic viability in the production of cyanides described in Section 6.5. However, the technique might be applicable in cases where chemical treatments (i.e. chemical oxidation) are not feasible or possible (such as in low volume, end-use applications where a dedicated waste water treatment plant is not economically viable).

#### Reference literature

<http://www.cordis.lu/fp5/projects.htm>

<http://www.cordis.lu/fp6/projects.htm#search>

<http://www.cordis.lu/en/home.html>



## 8 CONCLUDING REMARKS

The IPPC Directive does not define the term ‘Speciality Inorganic Chemicals’ and there is no common definition of this term in industry. This has created difficulty in defining the scope for this document and necessitates careful management of the possible interface with other chemical BREFs, in particular the LVIC-S BREF [24, European IPPC Bureau, 2004].

It is important to note that the end-of-pipe abatement techniques reported to be used in the SIC sector in the course of this work are all techniques commonly used in the chemical sector which are described in more detail in the CWW BREF [21, European IPPC Bureau, 2003].

There were some questions at the beginning of this work which included whether or not hydrocyanic acid (HCN, which is an important raw material for SIC substances – e.g. cyanides, see Section 6.5) and hydrazine were to be considered in the scope of SIC. It was considered that these two substances are not SIC substances. However, they are both inorganic chemicals and their production gives rise to environmental issues of importance and therefore warrants being covered in a BREF document. As hydrocyanic acid is a chemical produced in large volume, its production could be addressed in a revision of the LVIC-AAF BREF. With regard to hydrazine, there are only two producers in Europe utilising different production routes and in a situation of fierce competition, hence this could be an obstacle to a meaningful exchange of information on BAT.

### 8.1 Timing of the work

The information exchange on Best Available Techniques (BAT) for the production of SIC was carried out in a period of about two years, from October 2003 to November 2005. The work involved two plenary TWG meetings and two full drafts of this document were issued for consultation to the whole TWG. The milestones for the work on this document are shown in Table 8.1.

Kick-off meeting (1 <sup>st</sup> plenary TWG meeting)	27 – 28 October 2003
First draft issued for consultation	September 2004
Second draft issued for consultation	May 2005
Final meeting to conclude on BAT (2 <sup>nd</sup> plenary TWG meeting)	21 – 24 November 2005

**Table 8.1: Milestones for the work on the Speciality Inorganic Chemicals BREF**

After the final meeting, a short consultation of the TWG on the Executive summary, Concluding remarks, and the revised BAT chapter and sections was organised before the final draft of this document was produced.

### 8.2 Sources of information and development of this document

Because it was decided at the kick-off meeting to focus on six families of SIC substances (i.e. speciality inorganic pigments, phosphorus compounds, silicones, inorganic explosives, cyanides and inorganic salts of nickel), the information submitted only dealt with these families, thus only partially covering the whole SIC sector which would obviously cover a greater number of chemical substances.

The TWG (composed of 67 experts from Member States, Industry and the European Commission along with an Environmental NGO) was the main source of information used to elaborate this document.

The TWG provided input to the work on SIC mainly through:

- reports/documents elaborated to provide targeted information for the development of this document (i.e. for each of the illustrative families of SIC substances addressed)
- comments made to the two drafts issued (about 600 comments were received on the first draft and about 400 comments were received on the second)
- responses to requests for additional information developed by the European IPPC Bureau
- responses to e-mails and telephone calls from the European IPPC Bureau
- site visits.

The reports submitted by Germany [2, Dr. Köppke, 2003, 5, Dr. Köppke, 2003, 11, Dr. Köppke, 2004, 17, Rudolph and Köppke, 2003], Cefic [10, ANFFECC/CERAMICOLOR/EPSON/VdMi, 1998, 16, CEFIC Cyanide Sector and Working Group, 2004], and UEE [15, Castresana, 2004] can be considered the main building blocks for the first draft of this document.

Despite the fact that, when issuing the first draft, attention of the TWG was drawn to the lack of information regarding consumption and emission levels in the SIC sector and techniques to consider in the determination of BAT (Chapter 4 and Sections 6.X.4 of this document), only limited additional information was sent in response to the consultation on the first draft. However, the second draft supplemented Chapter 4 (on common techniques to consider in the determination of BAT) mainly with techniques derived from the specific/illustrative part of this document (Chapter 6) and from the CWW BREF.

In the second draft of this document, the section on soluble inorganic salts of nickel (which appeared in Section 6.6 of the first draft) was removed. This decision was taken because the work on this section did not progress at the same speed as the other sections and that bringing this section to the same level of completion could have compromised the objective of holding the final plenary TWG meeting before the end of 2005 (the final TWG meeting took place from 21 to 24 November 2005). The information exchanged on the production of soluble inorganic salts of nickel made it difficult, even impossible, to come to BAT conclusions. Despite this, and in order to keep the very valuable information that was provided for future use (e.g. for the revision of this document), a separate document that compiles the results of the information exchanged on the production of these substances was prepared [49, European IPPC Bureau, 2005]. Furthermore, it should be noted that the generic/common parts have been developed so that this document could be used in the permitting process of installations producing speciality chemicals not specifically covered in Chapter 6.

Some information for the work on SIC was also obtained by visiting SIC installations. A total of nine SIC installations were visited by the European IPPC Bureau for this document. These visits were made to Italy (for pigments), France (for silicones), Spain (for explosives), Germany (for phosphorus compounds and cyanides) and Finland (for inorganic salts of nickel). These visits were organised and generally accompanied by one TWG member.

In addition, the European IPPC Bureau developed a questionnaire in order to gather site-specific (or installation-specific) data in particular on consumption and emission levels as well as on techniques used to minimise environmental impacts at SIC installations. However, a very limited number of these questionnaires were filled in and returned to the European IPPC Bureau. Industry indicated that the lack of response was due to concerns over confidentiality of some data requested. The questionnaire is presented as an Annex to this document (See Section 9.1).

### 8.3 Degree of consensus reached

The conclusions of the work, and especially on BAT for the SIC sector, were agreed at the final plenary TWG meeting in November 2005. Consensus has been achieved and no split views were recorded during this final meeting. This should be seen in the perspective that there was little actual performance data supplied by industry. The main reasons indicated were the high competition and the small number of companies in certain SIC sectors (in particular for the production of silicones and phosphorus compounds).

No generic BAT conclusions on the abatement of heavy metals in waste water were derived. However, BAT conclusions on heavy metals abatement from waste water specific to three out of the five illustrative families of SIC substances addressed in this document have been drawn: for speciality inorganic pigments (see Section 6.1.5, BAT 6.1.11 and BAT 6.1.12), for silicones (see Section 6.2.5, BAT 6.3.14) and for inorganic explosives (see Section 6.4.5, BAT 6.4.7). For information on heavy metals abatement in the production of substances not covered in the illustrative families sections of this document, the TWG recommends reference to the CWW BREF [21, European IPPC Bureau, 2003].

### 8.4 Recommendations for future work

Because many environmentally beneficial techniques used in the SIC sector have already been described in other BREF documents (mainly in the CWW BREF), they are only briefly described in Chapter 4 of this document. However, specific issues regarding the application of these techniques to the SIC industry sector are not always indicated, especially under the headings Operational data, Applicability, and Example plants. Future work could provide the missing information.

There is generally a lack of actual performance data on consumption and emission levels and more specifically data on energy and water consumption. In the area of SIC explosives, the data presented are mainly derived from one Spanish installation (although inorganic explosives production has been identified in several EU countries in the course of the work – it is thought that every Member State has installations producing inorganic explosives for defence purposes). The lack of data for explosives did not allow the TWG to derive BAT associated consumption and emission levels for the treatment of waste water in the production of SIC explosives. In the area of silicones, phosphorus compounds and cyanides, the data provided were aggregated, making it difficult to determine BAT and BAT associated consumption and emission levels. Industry explained that some SIC companies were reluctant to provide installation-specific (i.e. disaggregated) performance data due to concerns that these data could be presented in this document in a way that could not guarantee confidentiality or in a way that could lead competitors to estimate costs of production (which Industry explained to be against competition laws). Future work could look for additional actual (disaggregated) performance data for each of the illustrative families already covered in this document as well as for any new illustrative family. This would help derive BAT associated consumption and emission levels in particular for the treatment of waste water in the production of silicones and to augment the number of pollutants addressed in the BAT conclusion regarding the abatement of heavy metals in the production of inorganic pigments (BAT 6.1.12). To preserve the confidentiality of information as well as to respect competition laws, the disaggregated data considered sensitive could be presented in this document in an aggregated way once the European IPPC Bureau has carried out the necessary analysis.

There was a lack of information on techniques used or that could be used in the SIC sector to save energy or to recover heat/energy. This information could be collected together with the associated performance data. This is especially important for SIC energy-intensive productions such as pigments, phosphorus compounds and silicones.

There was a lack of information received from the ten new Member States despite the fact that SIC installations have been identified in these countries (e.g. inorganic explosives, cyanides). Future work could provide the missing information.

There is very little information about monitoring in this document. Furthermore, when data on consumption and emission levels were submitted, the monitoring regime associated with the data was not always provided. This generated some lack of clarity in certain BAT conclusions where associated emission levels are used (e.g. the generic BAT conclusion on the abatement of total dust, the BAT conclusion on total dust abatement in the production of inorganic pigments). Future work could look at this issue more closely (e.g. characteristic emissions of the sector, special monitoring issues, sector-specific and substance-specific monitoring techniques, quality assurance of the whole information chain concerning monitoring).

As indicated previously in Section 8.2, as well as in other parts of this document, the exchange of information on soluble inorganic salts of nickel could not be carried out to such an extent that BAT conclusions could be drawn, and it was consequently decided to remove the section on inorganic salts of nickel. Building up on the information already submitted which has been compiled in a separate document (see Section 8.2), future work could bring the missing information that will allow BAT conclusions to be drawn for this family of SIC (in particular actual performance data on consumptions and emissions as well as candidate techniques to be considered for BAT). In addition, soluble inorganic salts of nickel are not the only inorganic salts that could be considered in the scope of SIC. Future work could therefore include enlarging the information exchange to other inorganic salts (e.g. inorganic salts of copper that are sometimes produced at the same installations as the nickel salts).

The production of speciality inorganic pigments by chemical processes is covered by this document and is addressed in Section 6.1. There are other production routes for the production of speciality inorganic pigments (e.g. iron oxides), i.e. using non-chemical production processes. Future work could provide for a comparison between chemical production routes and non-chemical production routes.

### **8.5 Suggested topics for future R&D projects**

This work has identified that dust is a major environmental issue in the production of SIC. The TWG identified several important factors to take into account when choosing dust abatement systems. These factors relate both to the dust characteristics (e.g. size, weight, hardness – see Section 4.4.2.1), as well as to the properties of the carrier gas (e.g. flowrate, temperature, humidity). However, the information presented in this document does not correlate these factors with the abatement techniques presented to abate dust (the dust abatement techniques are described in Section 4.4.2.1). There would, therefore, be a benefit in conducting research on the relevance of these factors for each of the techniques presented. This would not only benefit a possible future revision of this document but also the revision of other BREFs, in particular the CWW BREF.

In the production of inorganic explosives, lead in waste water is removed by precipitation. When soda ash is used as the precipitating agent, the lead concentration in the water effluent after the precipitation step is still relatively high (e.g. 5 mg/l at a Spanish installation). Research may identify the specific conditions in the production of explosives that limit the performance of precipitation and ways to overcome them.

The EC is launching and supporting, through its RTD programmes, a series of projects dealing with clean technologies, emerging effluent treatment and recycling technologies and management strategies. Potentially these projects could provide a useful contribution to future BREF reviews. Readers are therefore invited to inform the European IPPC Bureau of any research results which are relevant to the scope of this document (see also the preface of this document).



---

**REFERENCES**

- 1 Ullmann (2001). "Encyclopedia of Industrial Chemistry, Sixth Edition, Electronic Release".
- 2 Dr. Köppke, K.-E. (2003). "Manufacture of Phosphorus Compounds", German Federal Environmental Agency, Berlin.
- 3 UNEP; ILO and WHO (1989). "Phosphorus trichloride and phosphorus oxychloride health and safety guide", World Health Organization (WHO), <http://www.inchem.org/documents/hsg/hsg/hsg035.htm>.
- 5 Dr. Köppke, K.-E. (2003). "Silicon and Silicon compounds", German Federal Environmental Agency, Berlin.
- 7 Dr. Held, W. (2003). "Silicones - Their Science, Production and Major Qualities", Centre Europeen des Silicones.
- 8 European IPPC Bureau (2003). "Reference Document on Best Available Techniques on Emissions from Storage", European Commission.
- 9 Vito (2001). "Beste Beschikbare Tecnieken voor de Gieterijen", 90 382 0312 8.
- 10 ANFFECC/CERAMICOLOR/EPSOM/VdMi (1998). "Ceramic Decorating Materials".
- 11 Dr. Köppke, K.-E. (2004). "BAT Notes for the Production of Silicones", CES - Centre Européen des Silicones.
- 15 Castresana, J. M. (2004). "SIC-EXPLOSIVES - CONTRIBUTION FROM UEE", Union Española de Explosivos, S.A.
- 16 CEFIC Cyanide Sector and Working Group (2004). "Proposal for BREF on Speciality Inorganic Chemicals (SIC) Cyanides", CEFIC.
- 17 Rudolph, P. D. and Köppke, D. (2003). "Investigations concerning Integrated Environmental Protection in Certain Industrial Productions (Manufacture of Speciality Chemicals) Industrial Inorganic Pigments", Federal Environmental Agency, Berlin.
- 18 European IPPC Bureau (2004). "Draft Reference Document on Best Available Techniques for the Manufacture of Organic Fine Chemicals", European Commission.
- 21 European IPPC Bureau (2003). "Reference Document on Best Available Techniques in Common Waste Water and Waste Gas Treatment / Management Systems in the Chemical Sector", European Commission.
- 24 European IPPC Bureau (2004). "Draft Reference Document on Best Available Techniques for the Production of Large Volume Inorganic Chemicals (Solids and others)", European Commission.
- 29 Cefic (2004). "Facts and Figures", Cefic, [http://www.cefic.org/factsandfigures/level02/profile\\_index.html](http://www.cefic.org/factsandfigures/level02/profile_index.html).
- 30 European IPPC Bureau (2003). "Reference Document on Best Available Techniques in the Large Volume Organic Chemical Industry", European Commission.
- 31 European IPPC Bureau (2000). "Reference Document on the application of Best Available Techniques to Industrial Cooling Systems", European Commission.

- 32 European IPPC Bureau (2004). "Draft Reference Document on Best Available Techniques for Large Combustion Plants", European Commission.
- 33 European Industrial Gases Association (1999). "Hazards of inert gases", IGC Doc 44/00/E.
- 34 European IPPC Bureau (2004). "Draft Reference Document on the Best Available Techniques for Waste Incineration", European Commission.
- 35 European IPPC Bureau (2004). "Draft Reference Document on Best Available Techniques for the Waste Treatments Industries", European Commission.
- 36 European IPPC Bureau (2003). "Reference Document on the General Principles of Monitoring", European Commission.
- 37 European IPPC Bureau (2003). "Draft Reference Document on Economics and Cross-Media Effects", European Commission.
- 38 Dr. Boenke, A. (2005). "List of Different Research Projects Relevant to Speciality Inorganic Chemicals (SIC) BREF", European Commission.
- 39 Karschunke, K. (2004). "Additional Information from UBA-Germany on the production of inorganic pigments", German Federal Environmental Agency, Berlin.
- 40 ZANTE, H. (2004). "Comments from SFEPA on BREF "Speciality inorganic chemical (SIC) explosives"".
- 41 H2O2.com (2003). "Cyanide treatment with peroxygen compounds", H2O2.com, <http://www.h2o2.com/applications/industrialwastewater/cyanide.html>.
- 45 European IPPC Bureau (2004). "Draft Reference Document on Best Available Techniques in the Large Volume Inorganic Chemicals, Ammonia, Acids and Fertilisers Industries", European Commission.
- 46 Research and Markets (2001). "The Chemical Industry Market Report - Jan 2001", Key Note Publications Ltd, [http://www.reserachandmarkets.com/reportinfo.asp?report\\_id=3870](http://www.reserachandmarkets.com/reportinfo.asp?report_id=3870).
- 47 Dr Pflug, K. (2003). "Participation models in speciality chemicals", Arthur D Little Chemicals Executive Newsletter, Summer 2003.
- 49 European IPPC Bureau (2005). "Information Exchanged on the Production of Soluble Inorganic Salts of Nickel between October 2003 and April 2005".

## GLOSSARY OF TERMS AND ABBREVIATIONS

TERM or ABBREVIATION	MEANING
Abhesives	Abhesives are films or coatings that are used to prevent or greatly decrease adhesion.
Acid	Proton donor. A substance that, more or less readily, gives off hydrogen ions in a water solution.
Acute effect	An adverse effect on any living organism in which severe symptoms develop rapidly and often subside after the exposure stops.
Acute toxicity	Adverse effects that result from a single dose or single exposure of a chemical; any poisonous effect produced within a short period of time, usually less than 96 hours. This term is normally used to describe effects in experimental animals. Acute toxicity is measured by determining the LD <sub>50</sub> value. The LD <sub>50</sub> is the amount of material usually expressed for oral route as dosage in mg of chemical/kg body weight of the test animal) administered once by a given route (oral, dermal, etc.) that would be expected to kill 50 % of a group of experimental animals, usually rats.
Aeration	The act of mixing a liquid with air (oxygen).
Aggregate	A collection of primary particles that have fused to form a face-to-face sintered structure.
Agglomerate	A network of aggregates loosely connected at discrete points.
Al	Aluminium.
Al <sub>2</sub> O <sub>3</sub>	Aluminium oxide.
Alkali	Various water soluble compounds capable of turning litmus blue and reacting with an acid to form a salt and water.
Aniline	An organic base belonging to the phenylamines. It is a colourless, oily poisonous liquid amine. It may be regarded as ammonia in which one hydrogen atom has been replaced by the radical phenyl.
AOX	Adsorbable organic halogen compounds. The total concentration in milligrams per litre, expressed as chlorine, of all halogen compounds (i.e. chlorine, bromine, iodine, astatine, except fluorine) present in a sample of water that are capable of being adsorbed on activated carbon.
As	Arsenic.
Ba	Barium.
BAT	Best Available Techniques.
Bi	Bismuth.
Biodegradable	That can be broken down physically and/or chemically by micro-organisms. For example, many chemicals, food scraps, cotton, wool and paper are biodegradable.
BOD	Biochemical Oxygen Demand: the quantity of dissolved oxygen required by micro-organisms in order to decompose organic matter. The unit of measurement is mg O <sub>2</sub> /l. In Europe, BOD is usually measured after 3 (BOD <sub>3</sub> ), 5 (BOD <sub>5</sub> ) or 7 (BOD <sub>7</sub> ) days.
BREF	BAT reference document.
BTEX	Benzene, Toluene, Ethylbenzene, or Xylenes.
°C	Degree Celsius.
CaCl <sub>2</sub>	Calcium chloride.
CAS	Chemical Abstracts Service.
Cd	Cadmium.
Cefic	European chemical industry council.
CEH	Chemical Economics Handbook.
CHF	Swiss Franc.

TERM or ABBREVIATION	MEANING
CHP	Combined Heat and Power.
CIC	Complex Inorganic Coloured (pigments).
CIP	Cleaning-In-Place system.
Cl	Chlorine.
Cl <sup>-</sup>	Chloride ion.
Cl <sub>2</sub>	Chlorine gas.
CN <sup>-</sup>	Cyanide ion.
Co	Cobalt.
CO	Carbon monoxide.
CO <sub>2</sub>	Carbon dioxide.
CO <sub>3</sub> <sup>2-</sup>	Carbonate ion.
COD	Chemical Oxygen Demand: the amount of potassium dichromate, expressed as oxygen, required to chemically oxidise at about 150 °C substances contained in waste water.
Cooling water	Water used for energy transfer (cooling, heating), which is kept in a network separated from industrial water and which can be released back to receiving waters without further treatment.
Cr	Chromium.
Cr(III)	Trivalent chromium.
Cr(VI)	Hexavalent chromium.
Cross-media effects	The calculation of the environmental impacts of water/air/soil emissions, energy use, consumption of raw materials, noise and water extraction (i.e. everything required by the IPPC Directive).
Cu	Copper.
CWW	BREF on Common Waste Water and Waste Gas Treatment/Management Systems in the Chemical Sector.
dB	Decibel(s).
DC	Direct Current.
Diffuse emission	Emissions arising from direct contact of volatile or light dusty substances with the environment (atmosphere, under normal operating circumstances). These can result from: <ul style="list-style-type: none"> <li>- inherent design of the equipment (filters, dryers, etc.)</li> <li>- operating conditions (e.g. during transfer of material between containers)</li> <li>- type of operation (e.g. maintenance activities)</li> <li>- or from a gradual release to other media (e.g. to cooling water or waste water).</li> </ul> Fugitive emissions are a subset of diffuse emissions and commonly refer to substances that enter the environment through leaks from equipment. For dusty substances the term diffuse emissions is more commonly used. See also the definition of 'Fugitive emissions' below.
Diffuse sources	Sources of similar diffuse or direct emissions which are multiple and distributed inside a defined area.
Dross	The scum or refuse matter which is thrown off, or falls from, metals in smelting the ore, or in the process of melting.
DS	Dry Solids (content). The mass of a material remaining after drying by the standard method of test.
DSA	Dimensionally Stable Anodes.
Dust	A solid, mechanically produced particle with a size ranging from submicroscopic to macroscopic.
EC	European Community.

TERM or ABBREVIATION	MEANING
EC <sub>50</sub>	Effect Concentration 50. The concentration at which effects are observed in 50 % of the test population after administering a single dose. Effects include the immobilisation of daphnia, inhibition of growth, cell division or biomass production, or the production of chlorophyll by algae.
Effluent	Physical fluid (air or water together with contaminants) forming an emission.
EINECS	European Inventory of Existing Commercial Substances.
EIPPCB	European IPPC Bureau.
Electrolysis	A process that decomposes a chemical compound or produces a new compound by the action of an electrical current. The electrical current is passed through an electrolytic cell and oxidation/reduction reactions occur at the electrodes; for example, water can be decomposed into hydrogen and oxygen by electrolysis.
Emission	The direct or indirect release of substances, vibrations, heat or noise from individual or diffuse sources in the installation into the air, water or land.
Emission limit values	The mass, expressed in terms of certain specific parameters, concentration and/or level of an emission, which may not be exceeded during one or more periods of time.
End-of-pipe technique/measure	A technique/measure that reduces final consumptions or emissions by some additional process but does not change the fundamental operation of the core process. Synonyms: 'secondary technique/measure', 'abatement technique/measure'. Antonyms: 'process-integrated technique/measure', 'primary technique/measure' (a technique/measure that in some way changes the way in which the core process operates thereby reducing raw consumptions or emissions).
EOP	End-Of-Pipe.
EOX	Total Extractable Organic halides.
EPER	European Pollutant Emission Register.
ESP	Electrostatic Precipitator.
Eutrophication	The pollution of a body of water by sewage, fertilisers washed from the land, and industrial wastes (inorganic nitrates and phosphates). These compounds stimulate the growth of algae, reducing the oxygen content in the water, and so killing animals with a high oxygen requirement.
EU	European Union.
EUR	Euro currency.
EU-15	The first 15 countries that joined the European Community/Union.
Existing installation	An installation in operation or, in accordance with legislation existing before the date on which this Directive is brought into effect, an installation authorised or in the view of the competent authority the subject of a full request for authorisation, provided that that installation is put into operation no later than one year after the date on which this Directive is brought into effect.
Fe	Iron.
FGD	Flue-Gas Desulphurisation.
FHM	Flocculation agent.
Flocculation	The process in which particles in a colloid aggregate into larger clumps. Often, the term is used for a reversible aggregation of particles in which the forces holding the particles together are weak and the colloid can be redispersed by agitation.

TERM or ABBREVIATION	MEANING
Fugitive emission	Emission caused by non-tight equipment/leak: emission into the environment resulting from a gradual loss of tightness from a piece of equipment designed to contain an enclosed fluid (gaseous or liquid), basically caused by a difference of pressure and a resulting leak. Examples of fugitive emissions: leak from a flange, a pump, a sealed or tightened equipment.
g	Gram.
GAC	Granular Activated Carbon.
GDP	Gross Domestic Product.
GE	General Electric company.
h	Hour.
H	Hydrogen.
H <sup>+</sup>	Hydrogen ion.
Hazardous wastes	Wastes which have hazardous properties that may render it harmful to human health or the environment.
HCl	Hydrogen chloride. Hydrochloric acid.
HCN	Hydrogen cyanide. Hydrocyanic acid.
HCOO <sup>-</sup>	Formate.
H <sub>2</sub> O	Water.
H <sub>2</sub> O <sub>2</sub>	Hydrogen peroxide.
H <sub>2</sub> SO <sub>4</sub>	Sulphuric acid.
HEAF	High Efficiency Air Filter.
HEPA	High Efficiency Particle Arrestation (filter).
Heavy metals	Technical literature describes these as metals with a density greater than 4.5 g/ml. By this definition, most chemical elements are heavy metals.
HF	Hydrogen fluoride.
Hg	Mercury.
HNO <sub>3</sub>	Nitric acid.
HP	High Pressure.
HVU	High Vacuum Unit. Production unit (step in the production line) which operates under high vacuum.
IARC	International Agency for Research on Cancer.
IBCs	Intermediate Bulk Containers.
IEF	Information Exchange Forum (informal consultation body in the framework of the IPPC Directive).
Inert gas	A gas which is not toxic, which does not support human breathing and which reacts scarcely or not at all with other substances. Inert gases are mainly nitrogen and the rare gases like helium, argon, neon, xenon, krypton.
Installation	A stationary technical unit where one or more activities listed in Annex I are carried out, and any other directly associated activities which have a technical connection with the activities carried out on that site and which could have an effect on emissions and pollution.
IPC	The precursor of IPPC in the UK.
IPPC	Integrated Pollution Prevention and Control.
ISO	International Organisation for Standardisation.
J	Joule(s).
k	Kilo(s).
K <sup>+</sup>	Potassium ion.
KCN	Potassium cyanide.
KOH	Potassium hydroxide.
kPa	Kilo pascal(s).
kW	Kilowatt(s).

TERM or ABBREVIATION	MEANING
kWh	Kilowatt(s)-hour(s).
LA	Lead azide.
LC <sub>50</sub>	Lethal Concentration 50. The lowest concentration of a substance in water or ambient air in milligrams per litre sufficient to cause death in 50 % of the test population within a defined period (e.g. 96 hours for fish, 48 hours for daphnia).
LD <sub>50</sub>	Lethal Dose 50. The lowest dose of a substance administered to species such as mice and rats sufficient to cause death in 50 % of the test population within a defined period (no more than 14 days), expressed in milligrams of test substance per kilogram of body weight.
LEL	Lower Explosive Limit.
LP	Low Pressure. Lead Picrate.
LTNR	Lead trinitroresorcinate.
LVIC	Large Volume Inorganic Chemicals.
LVIC-S	Large Volume Inorganic Chemicals – Solids and others.
LVOC	Large Volume Organic Chemicals.
Matte	A mixture of sulphides that forms when sulphide metal ores (containing e.g. nickel, copper, cobalt) are smelted.
MeCl	Methyl chloride.
MF	Microfiltration (membrane process).
MeOH	Methanol.
mg	Milligram(s).
m <sup>3</sup>	Cubic metre(s).
Monitoring	Process intended to assess or to determine the actual value and the variations of an emission or another parameter, based on procedures of systematic, periodic or spot surveillance, inspection, sampling and measurement or other assessment methods intended to provide information about emitted quantities and/or trends for emitted pollutants.
Mother liquor	Waste water stream directly arising from a synthesis or chemical reaction, generally highly concentrated in products, starting material or by-products, especially the initial aqueous discharges.
MPa	Mega Pascal(s).
Multi-media effects	See <i>cross-media effects</i> .
MW	Megawatt(s).
MWh	Megawatt(s)-hour(s).
N	Nitrogen.
N <sub>2</sub>	Nitrogen gas.
N/A or n/a	Not applicable OR not available (depending on the context).
N/D or n/d	No data.
NACE	National Association of Corrosion Engineers.
NaOCl	Sodium hypochlorite.
NaClO <sub>4</sub>	Sodium perchlorate.
NaCN	Sodium cyanide.
NaNO <sub>2</sub>	Sodium nitrite.
NaOH	Sodium hydroxide. Also called caustic soda.
Na <sub>2</sub> Cr <sub>2</sub> O <sub>7</sub>	Sodium dichromate.
Na <sub>2</sub> CO <sub>3</sub>	Sodium carbonate, soda. Also called soda ash.
NF	Nanofiltration (membrane process).
NFM	Non-Ferrous Metal (BREF).
ng	Nanogram(s).
NGO	Non-Governmental Organisation.

TERM or ABBREVIATION	MEANING
NH <sub>3</sub>	Ammonia.
NH <sub>4</sub> <sup>+</sup>	Ammonium ion.
NH <sub>4</sub> -N	Nitrogen content in the form of NH <sub>3</sub> or NH <sub>4</sub> <sup>+</sup> .
Ni	Nickel.
Nm <sup>3</sup>	Normal cubic metre(s). Typically at 0 °C and 101.3 kPa.
N <sub>2</sub> O	Nitrous oxide.
NO	Nitrogen oxide.
NO <sub>2</sub>	Nitrogen dioxide.
NO <sub>3</sub> <sup>-</sup>	Nitrate.
NO <sub>3</sub> -N	Nitrogen nitrate.
NO <sub>x</sub>	Nitrogen oxides (mixture of NO and NO <sub>2</sub> ).
O <sub>2</sub>	Oxygen gas.
O <sub>3</sub>	Ozone.
OCl <sup>-</sup>	Hypochlorite ion.
OCN <sup>-</sup>	Cyanate ion.
OFC	Organic Fine Chemicals.
OJ	Official Journal.
Operator	Any natural or legal person who operates or controls the installation or, where this is provided for in national legislation, to whom decisive economic power over the technical functioning of the installation has been delegated.
P	Phosphorus.
Pa	Pascal. A unit of pressure equal to one newton per square metre.
PAC	Powdered Activated Carbon.
Pb	Lead.
PCB	Polychlorinated Biphenyls.
PCDD	Polychlorinated dibenzodioxins.
PCDF	Polychlorinated dibenzofurans.
PDMS	Polydimethylsiloxane.
pH	Calculated by taking the logarithm of the concentration of the hydrogen ions present in solution: $\text{pH} = -\log_{10}[\text{H}^+]$ .
PI	Process-Integrated.
PLC	Programmable Logic Control.
PM	Particulate Matter. Any airborne finely divided solid or liquid material excluding uncombined water.
PM <sub>0.01</sub>	Particulate Matter with an aerodynamic diameter less than or equal to a nominal 0.01 micrometres.
PM <sub>0.1</sub>	Particulate Matter with an aerodynamic diameter less than or equal to a nominal 0.1 micrometres.
PM <sub>0.12</sub>	Particulate Matter with an aerodynamic diameter less than or equal to a nominal 0.12 micrometres.
PM <sub>0.3</sub>	Particulate Matter with an aerodynamic diameter less than or equal to a nominal 0.3 micrometres.
PM <sub>10</sub>	Particulate Matter with an aerodynamic diameter less than or equal to a nominal 10 micrometres.
PM <sub>2.5</sub>	Particulate Matter with an aerodynamic diameter less than or equal to a nominal 2.5 micrometres.
PM <sub>HAP</sub>	Hazardous air pollutants in particulate form.
PO <sub>4</sub> -P	Phosphorus content in the form of phosphates.
Pollutant	Individual substance or group of substances which can harm or affect the environment.
PPM or ppm	Parts Per Million.



TERM or ABBREVIATION	MEANING
Primary measure/technique	A technique that in some way changes the way in which the core process operates thereby reducing raw consumptions or emissions (see <i>end-of-pipe technique</i> ).
PSA	Pressure-Swing Adsorption.
PTFE	Politetrafluoro-ethylene.
RCO	Regenerative Catalytic Oxidation.
R&D	Research and Development.
RO	Reverse Osmosis (membrane process).
rpm	Rotation per minute.
RTD	Research and Technological Development.
RTO	Regenerative Thermal Oxidiser.
Salt	An ionic compound made of a cation and an anion, other than hydroxide.
Sb	Antimony.
SCR	Selective Catalytic Reduction.
SCWO	Super Critical Water Oxidation.
Secondary measure/technique	See <i>end-of-pipe technique</i> .
Slag	A product of smelting, containing, mostly as silicates, the substances not sought to be produced as matte or metal, and having a lower specific gravity than the latter. The slag of iron blast furnaces is essentially silicate of calcium, magnesium, and aluminium; that of lead and copper smelting furnaces contains iron.
SIC	Speciality Inorganic Chemicals.
SME	Small and Medium Enterprise(s).
Sn	Tin.
SNCR	Selective Non-Catalytic Reduction.
SnO	Tin monoxide.
SO <sub>2</sub>	Sulphur dioxide.
SO <sub>3</sub>	Sulphur trioxide.
SO <sub>4</sub> <sup>-</sup>	Sulphate ion.
SO <sub>x</sub>	Sulphur oxides (mixture of SO <sub>2</sub> and SO <sub>3</sub> ).
Specific emission	Emission related to a reference basis, such as production capacity, or actual production (e.g. mass per tonne or per unit produced).
SRI	Stanford Research Institute.
SS	Suspended Solids (content) (in water) (see also TSS).
t	Tonne(s).
TA Luft	German regulations.
TEQ	Toxic Equivalents. Used to report the toxicity-weighted masses of mixtures of dioxins/furans.
Ti	Titanium.
TiO <sub>2</sub>	Titanium dioxide.
TNR	Trinitroresorcinate.
TOC	Total Organic Carbon.
TS	Total Solids (content). Solid content before drying of the material.
TSS	Total Suspended Solids (content) (in water) (see also SS).
TWG	Technical Working Group.
UASB	Upflow Anaerobic Sludge Blanket reactor or process.
UBA	Umweltbundesamt (German Federal Environmental Agency).
UEB	Unión Explosivos-Ensign Bickford company.
UF	Ultrafiltration (membrane process).
UK	United Kingdom.
UN	United Nations.

## Glossary

---

<b>TERM or ABBREVIATION</b>	<b>MEANING</b>
UNEP	United Nations Environment Programme.
US	United States.
UV	Ultraviolet.
V	Vanadium
V.I.	Viscosity Index.
VOCs	Volatile Organic Compounds.
W	Tungsten.
WWTP	Waste Water Treatment Plant.
yr	Year.
Zn	Zinc.
ZnO	Zinc oxide.

## 9 ANNEXES

### 9.1 Annex I. Questionnaire used to gather environmental information on SIC installations

	EUROPEAN COMMISSION DIRECTORATE-GENERAL JRC JOINT RESEARCH CENTRE Institute for Prospective Technological Studies (Seville) European IPPC Bureau		
<b><u>IPPC QUESTIONNAIRE ON THE PRODUCTION OF SPECIALITY INORGANIC CHEMICALS (SIC)</u></b>			
<b>PURPOSE OF THE QUESTIONNAIRE</b>			
Within the framework of the implementation of the IPPC Directive and the elaboration of the European reference document on the Best Available Techniques (BAT) for the production of Speciality Inorganic Chemicals (SIC), the document also referred to as the			
<b>HOW IS THE SUBMITTED INFORMATION GOING TO BE USED?</b>			
The information submitted will only be used for the purpose of the SIC BREF and in a form that will prevent the identification from which specific company or production site it originates. The submitted data will only be dealt with by EIPPCB personnel (th			
<b>IF ANY DATA REQUESTED IS CONFIDENTIAL, PLEASE SPECIFY THIS</b>			
Confidentiality should not generally be an issue as the vast majority of consumption and emission data included in this questionnaire are provided to national permitting authorities and entered onto public registers (when they are not simply part of compa			
<b>WHAT IF I DON'T HAVE ALL THE INFORMATION REQUESTED?</b>			
You are asked to submit the information that you have to hand. Partial information is also useful.			
<b>WHICH CELLS DO I HAVE TO FILL?</b>			
The cells that require information or data are coloured blue. Please feel free to add any of your relevant information here.			
THE FOLLOWING FIGURE SUMMARISES HOW YOUR INSTALLATION NEEDS TO BE SEEN TO FILL THE QUESTIONNAIRE CORRECTLY			
<b>INPUTS</b>	<b>Speciality Inorganic Chemicals (SIC)</b> <b>Installation Assessed</b>	<b>OUTPUTS</b>	
<b>Person completing the questionnaire</b>			
<b>Name:</b>			
<b>Job title:</b>			
<b>e-mail:</b>			
<b>Tel.</b>			
This information will only be used if further clarification is needed.			
FOR FURTHER INFORMATION ON THIS QUESTIONNAIRE, PLEASE CONTACT:			
	Serge Roudier (EIPPCB), tel. 34+ 95 448 8308		
	e-mail: <a href="mailto:serge.roudier@cec.eu.int">serge.roudier@cec.eu.int</a>		
<b>WHEN COMPLETE, PLEASE SEND THIS QUESTIONNAIRE TO <a href="mailto:serge.roudier@cec.eu.int">serge.roudier@cec.eu.int</a></b>			

1. GENERAL INFORMATION ABOUT THE SIC INSTALLATION	
Country where the installation is located	
Name of the company	
Name of the installation (or city where it is located)	
Date of entry into operation	
Year of reference for the data provided in this questionnaire	
Additional information	



3. APPLIED PROCESSES AND TECHNIQUES AT THE SIC INSTALLATION			
Installation: -			
SPECIALITY CHEMICALS PRODUCED AT THE INSTALLATION			
Family of SIC substances produced			
	production of inorganic pigments (other than TiO <sub>2</sub> and carbon black)		
	production of inorganic explosives by chemical processes		
	production of cyanides		
	production of phosphorus compounds		
	production of silicones		
	production of soluble salts of nickel		
SIC substances produced			
By-products generated		Outcome	

**BRIEF DESCRIPTION OF THE PROCESSES**

Please mention the list of processes/activities carried out at your installation (storage already partially included). For a better understanding of your process, please add a flow chart of the installation to the next worksheet.

	Processes or activities carried out	Short description/Remarks	Outputs (i.e. emissions to air and water, residues, noise, odour)	Inputs (e.g. raw material, energy, water)
1	Gas storage			
2	Liquid storage			
3	Solid (including waste) storage			
4				
5				
6				
7				
8				
9				
10				
11				
12				
13				
14				
15				

AIR ABATEMENT SYSTEMS USED				
Please mention in the following table which types of flue-gas cleaning systems are used in your installation				
	Type of abatement system in use	Abatement efficiency* %	Basis of the efficiency*	Remarks
A1	Dry electrostatic precipitator		PM	
A2	Wet electrostatic precipitator		PM	
A3	Cyclone		PM	
A4	Quench			
A5	Bag filter		PM	
A6	Baghouse filter with active carbon injection		PM	
A7	Acid wet scrubber			
A8	Alkaline wet scrubber			
A22	Water scrubber			
A9	Additional scrubber system			
A10	Dry scrubber with lime injection			
A11	Non selective catalytic reduction		NO <sub>x</sub>	
A12	Selective catalytic reduction for NO <sub>x</sub>		NO <sub>x</sub>	
A13	Selective catalytic reduction for NO <sub>x</sub> and dioxins			
A14	Active carbon filter (steady)			
A15	VOC incinerator		VOC	
A16	Biofilter			
A17				
A18				
A19				
A20				
A21				
* if more than one pollutant is abated by the technique, please report abatement efficiency and the basis of the efficiency for each pollutant				
<b>Are you planning to implement any other air abatement technique within the next two years?</b>				
<b>NO</b>	If yes, please specify which.			



**WASTE WATER TREATMENT SYSTEMS USED**

Please mention the waste water treatments carried out in your installation which are not part of the waste water treatment plant (WWTP) in the following table

	Abatement system in use	Abatement efficiency %	Basis of the efficiency	Remarks
W11				
W12				
W13				
W14				
W15				
W16				
W17				
W18				

**WASTE WATER TREATMENT PLANT (WWTP)**

1) Is your installation generating waste water?

If yes, please respond to question 2)

2) Is the waste water generated by your installation treated in a WWTP?

If yes, please respond to question 3)

3) Is the WWTP only treating waste water generated by your installation

Overall efficiency  %  % In TOC terms

	Possible treatments contained in the WWTP	Applied	Remarks
W1	Sedimentation		
W2	Neutralisation		
W3	Chemical treatment with .....		
W4	Separation of emulsions		
W5	Filtration		
W6	Dewatering		
W7	Filter press		
W8	Ion exchange		
W9	Flocculation		
W10			
W11			
W12			
W13			
W14			
W15			

Are you planning to implement any other water treatment within the next two years?

NO If yes, please specify which.

### INCLUDE A FLOW CHART OF THE INSTALLATION HERE

#### Installation -

Ideally, the flow chart should show the various process steps, the flow of raw materials and finished products, and the main emissions.

### 4. OUTPUTS FROM THE SIC INSTALLATION

Installation: -

#### SIC PRODUCTS

Name of products with a positive market price			
Annual amount of products manufactured (tonnes/yr)			
Electricity (MWh/yr)			
Heat (MWh/yr)			

**Notes:** C=Continuous, D=Discontinuous, IM= Indirect measurement, E=estimated

If an emission parameter is not applicable for the process, include N/A in the table. If you know that there may be some emission but you don't have a value for it, please leave the cell blank.

AIR EMISSIONS	Types of measurement				
Parameter	(C, D, IM, E)	Concentration	Units	Load	Units
Averaging time period					
CO <sub>2</sub>					kg/yr
Dust			mg/Nm <sup>3</sup>		kg/yr
NH <sub>3</sub>			mg/Nm <sup>3</sup>		kg/yr
NO <sub>x</sub>			mg/Nm <sup>3</sup>		kg/yr
N <sub>2</sub> O			mg/Nm <sup>3</sup>		kg/yr
VOC (Volatile Organic Compounds)			mg/Nm <sup>3</sup>		kg/yr
SO <sub>x</sub>			mg/Nm <sup>3</sup>		kg/yr
CFC			mg/Nm <sup>3</sup>		kg/yr
Chlorobenzenes			mg/Nm <sup>3</sup>		kg/yr
CH <sub>4</sub>			mg/Nm <sup>3</sup>		kg/yr
CO			mg/Nm <sup>3</sup>		kg/yr
HCN			mg/Nm <sup>3</sup>		kg/yr
HCl			mg/Nm <sup>3</sup>		kg/yr
HF			mg/Nm <sup>3</sup>		kg/yr
H <sub>2</sub> S			mg/Nm <sup>3</sup>		kg/yr
Total metals			mg/Nm <sup>3</sup>		kg/yr
As			mg/Nm <sup>3</sup>		kg/yr
Hg			mg/Nm <sup>3</sup>		kg/yr
Cd			mg/Nm <sup>3</sup>		kg/yr
PAH			mg/Nm <sup>3</sup>		kg/yr
PCB			mg/Nm <sup>3</sup>		kg/yr
PCDD/PCDF			(ngTEQ/Nm <sup>3</sup> )		g/yr
Odour					
Noise					

Note: N means normal conditions (0°C and 1 atm). Please give the data from dry conditions.



5. GOOD ENVIRONMENTAL PRACTICES	
Installation: -	
<p>The information included in this worksheet concerns those techniques (which are already implemented or that will be implemented shortly in your installation) that you consider to be <b>Good Environmental Practices (GEP)</b>. For each technique, please provide i</p>	
Information	
Description	
Achieved environmental benefits	
Cross-media effects	
Operational data	
Applicability	
Economics	
Driving force for implementation	
Example plants	
Reference literature	
Information	
Description	
Achieved environmental benefits	
Cross-media effects	
Operational data	
Applicability	
Economics	
Driving force for implementation	
Example plants	
Reference literature	
<p><b>Duplicate the above format to provide information on all the techniques applied in your installation that you consider to be GEP</b></p>	